

Toggles

Rockers

Pushbuttons

Illuminated PB

Programmable

Keylocks

Rotaries

Slides

Tactiles

Tilt

Touch

Indicators

Accessories

Supplement



AB Series C6

0.4VA Logic Level; Process Sealed
Straight, Right Angle, & Vertical PC



BB Series C12

Antistatic; 0.4VA Logic Level; Process Sealed
Straight, Right Angle, & Vertical PC



DB Series C18

0.4VA Logic Level
Threaded Bushing with Straight PC
Smooth Bushing with Straight, Right Angle, & Vertical PC



EB Series C24

3A Power Level & 0.4VA Logic Level
Solder Lug & Straight PC
Bushing Mount



EB Series C30

3A Power Level
Solder Lug & Straight PC
Snap-in Mount



FB Series C38

500mA Power Level & 0.4VA Logic Level
PC Turret
Bushing Mount



GB Series C44

0.4VA Logic Level; Process Sealed
Straight, Right Angle, & Vertical PC



GB2 Series C48

0.4VA Logic Level
Straight & Right Angle PC



G3B Series C52

0.4VA Logic Level; Process Sealed
Gull Wing Terminals
Upright & Right Angle Mount



JP Series C58

10A or 16A Power Level
Solder Lug
Snap-in Mount



M2B Series C64

1A Power Level & 0.4VA Logic Level
Process Sealed
Straight, Right Angle, & Vertical PC



MB2000 Series C72

6A Power Level & 0.4VA Logic Level
Solder Lug, Quick Connect, Straight PC, & Wirewrap
Bushing Mount

Toggles

Rockers

C Pushbuttons

Illuminated PB

Programmable

Keylocks

Rotaries

Slides

Tactiles

Tilt

Touch

Indicators

Accessories

Supplement

Toggles

Rockers

Pushbuttons

Illuminated PB

Programmable

Keylocks

Rotaries

Slides

Tactiles

Tilt

Touch

Indicators

Accessories

Supplement

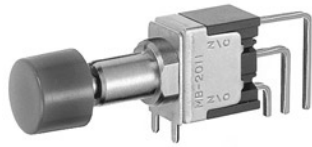

MB2000 Series C80

6A Power Level & 0.4VA Logic Level
Straight, Right Angle, & Vertical PC
PCB Mount



MB2000 Series C87

6A Power Level & 0.4VA Logic Level
Solder Lug, Quick Connect, Straight PC, & Wirewrap
Large Bushing (12mm)



MB2400 Series C96

3A Power Level & 0.4VA Logic Level
Solder Lug, Straight PC, & Wirewrap
Bushing Mount



MB2400 Series C102

3A Power Level & 0.4VA Logic Level
Straight, Right Angle, & Vertical PC
PCB Mount



MB2400 Series C108

3A Power Level & 0.4VA Logic Level
Solder Lug, Straight PC, & Wirewrap
Snap-in Mount



MB2500 Series C116

3A Power Level & 0.4VA Logic Level
Solder Lug & Straight PC
Bushing Mount



MB2500 SeriesC121

3A Power Level & 0.4VA Logic Level
Solder Lug & Straight PC
PCB Mount



MB2500 SeriesC124

3A Power Level & 0.4VA Logic Level
Solder Lug
Snap-in Mount



SB SeriesC128

3A to 15A Power Level
Solder Lug & Screw Lug
Bushing Mount



SB4011 Series C38

3A Power Level
Solder Lug
Bushing Mount



SCB SeriesC131

15A & 1/2 HP Power Level
Quick Connect
Bushing Mount



WB SeriesC134

Environmentally Sealed
6A Power Level
Solder Lug, Screw Lug, & Wire Lead
Bushing Mount

Supplement

Accessories

Indicators

Touch

Tilt

Tactiles

Slides

Rotaries

Keylocks

Programmable

Illuminated PB

C Pushbuttons

Rockers

Toggles

General Specifications

Electrical Capacity (Resistive Load)

Logic Level: 0.4VA maximum @ 28V AC/DC maximum
(Applicable Range 0.1mA ~ 0.1A @ 20mV ~ 28V)
Note: Find additional explanation of operating range in Supplement section.

Other Ratings

Contact Resistance: 50 milliohms maximum
Insulation Resistance: 500 megohms minimum @ 500V DC
Dielectric Strength: 500V AC minimum for 1 minute minimum
Mechanical Life: 50,000 operations minimum
Electrical Life: 50,000 operations minimum
Nominal Operating Force: 2.55N
Contact Timing: Nonshorting (break-before-make)
Travel: Pretravel .028" (0.7mm); Overtravel .016" (0.4mm); Total Travel .043" (1.1mm)

Materials & Finishes

Plunger: Polyacetal
Case Housing: Glass fiber reinforced polyamide
Support Bracket: Tin plated phosphor bronze
Movable Contact: Phosphor bronze with gold plating
Stationary Contacts: Brass with gold plating
Terminals: Brass with gold plating

Environmental Data

Operating Temp Range: -30°C through +85°C (-22°F through +185°F)
Humidity: 90 ~ 95% humidity for 96 hours @ 40°C (104°F)
Vibration: 10 ~ 55Hz with peak-to-peak amplitude of 1.5mm traversing the frequency range & returning in 1 minute; 3 right angled directions for 2 hours
Shock: 50G (490m/s²) acceleration (tested in 6 right angled directions, with 5 shocks in each direction)

Installation

Cap Installation Force: 49.03N (11.2 lbf) maximum downward force on actuator

PCB Processing

Soldering: Wave Soldering Recommended: See Profile A in Supplement section.
Manual Soldering: See Profile B in Supplement section.
Cleaning: Automated cleaning. See Cleaning specifications in Supplement section.

Standards & Certifications

The AB Series pushbuttons have not been tested for UL recognition or CSA certification. These switches are designed for use in a low-voltage, low-current, logic-level circuit. When used as intended in a logic-level circuit, the results do not produce hazardous energy.

Distinctive Characteristics

Subminiature size (1/3 size of Series M switches) saves space on PC boards.

Specifically developed for logic-level applications.

Totally sealed body construction prevents contact contamination and allows time- and money-saving automated soldering and cleaning.

Award-winning STC contact mechanism with benefits unavailable in conventional mechanisms: smoother, positive detent actuation, increased contact stability and unparalleled logic-level reliability. (Additional STC details in Terms & Acronyms; see Supplement section.)

Molded-in, epoxy sealed or ultrasonically welded terminals lock out flux, solvents, and other contaminants.

.100" x .100" (2.54mm x 2.54mm) terminal spacing conforms to standard PC board grid spacing.

Matching indicators available.

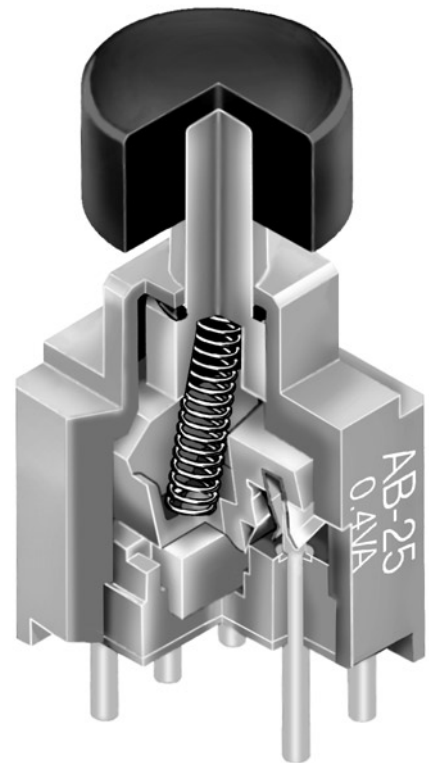

Actual Size

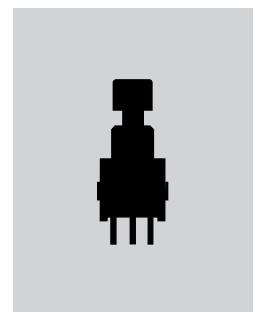

- Supplement
- Accessories
- Indicators
- Touch
- Tilt
- Tactiles
- Slides
- Rotaries
- Keylocks
- Programmable
- Illuminated PB
- Pushbuttons
- Rockers
- Toggles

TYPICAL SWITCH ORDERING EXAMPLE

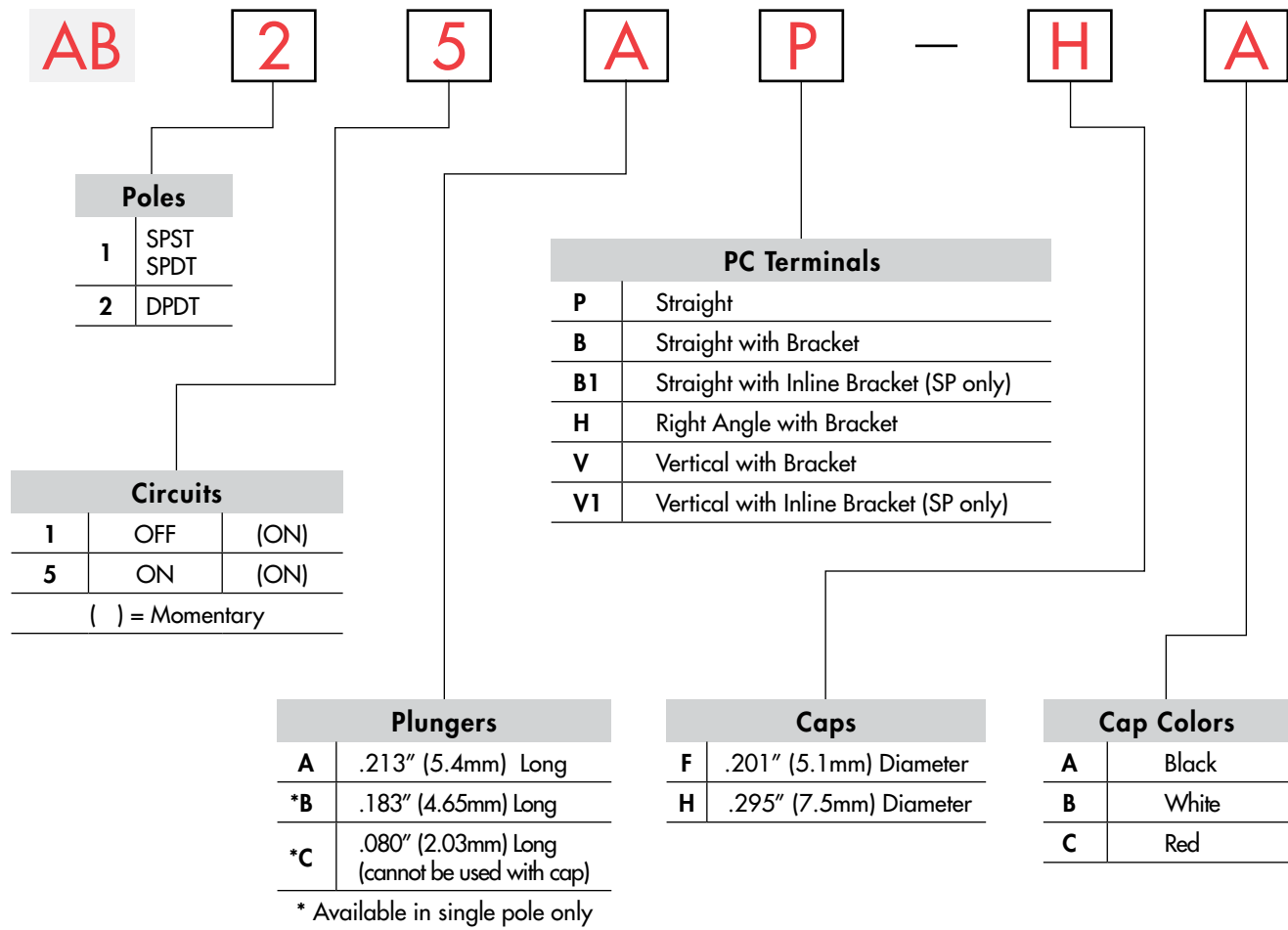

DESCRIPTION FOR TYPICAL ORDERING EXAMPLE

AB25AP-HA

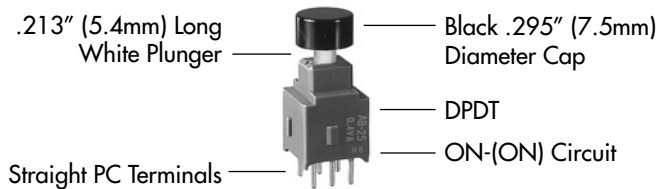

Toggles
 Rockers
 Pushbuttons
 Illuminated PB
 Programmable
 Keylocks
 Rotaries
 Slides
 Tactiles
 Tilt
 Touch
 Indicators
 Accessories
 Supplement

POLES & CIRCUITS

Pole	Model	Plunger Position () = Momentary		Connected Terminals		Throw & Schematics
		Normal	Down	Normal	Down	
SP	AB11	OFF 	(ON) 	OPEN 	3-1 	SPST Note: Terminal numbers are not actually on the switch.
SP	AB15	ON 	(ON) 	2-3 	2-1 	SPDT
DP	AB25	ON 	(ON) 	2-3 5-6 	2-1 5-4 	DPDT

PLUNGERS

A .213" (5.4mm)
Long

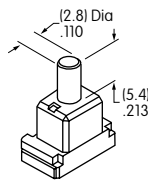

B .183" (4.6mm)
Long
(on SP only)

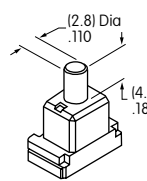

C .080" (2.03mm)
Long
(on SP only)

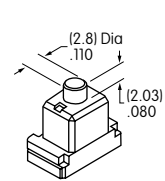

Standard Plunger Color: White Contact factory for red or black options.

PC TERMINALS

P Straight

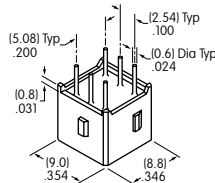

B Straight
with Bracket

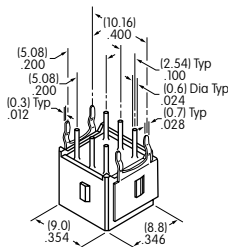

H Right Angle
with Bracket

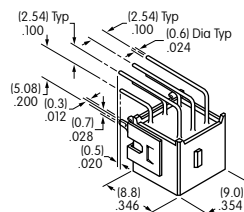

V Vertical
with Bracket

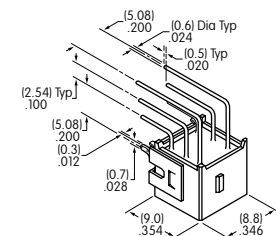

Use of a support bracket is recommended to increase PCB mounting strength and stability.
B1 & V1 terminal dimensions appear on the pushbutton drawings which follow.

SLIP-ON CAPS

F AT475
.201" (5.1mm) Diameter Cap

Material: Polyamide
For use with
plungers A & B only.

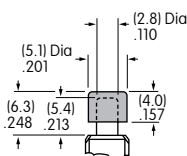

H AT496
.295" (7.5mm) Diameter Cap

Material: Polyamide
For use with
plungers A & B only.

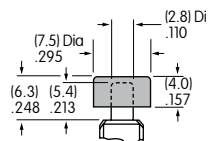

Colors Available:

A Black

B White

C Red

TYPICAL SWITCH DIMENSIONS

Straight PC

Single Pole

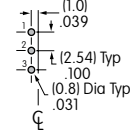
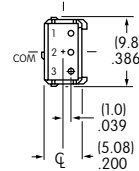
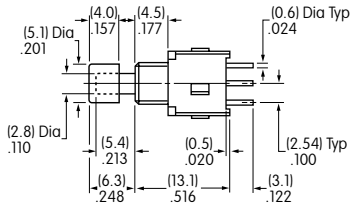
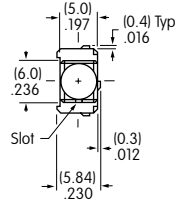

AB15AP-FA

AB11 model does not have terminal 2.

Straight PC

Double Pole

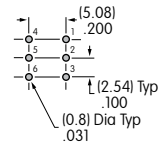
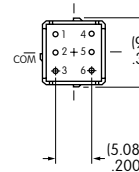
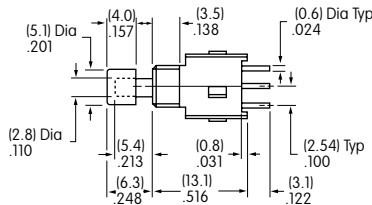
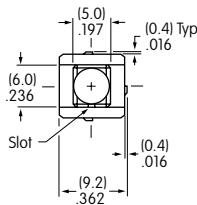

AB25AP-FA

Straight PC • Bracket

Single Pole

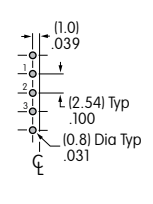
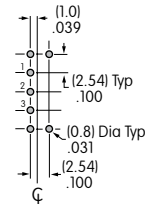
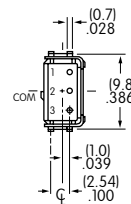
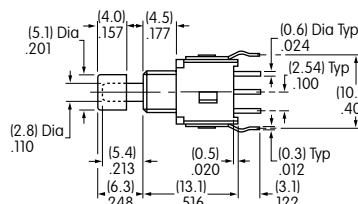
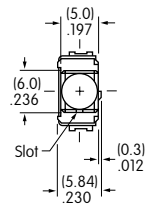

AB15AB-FA

B Terminals

B1 Terminals

Straight PC • Bracket

Double Pole

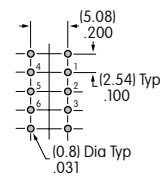
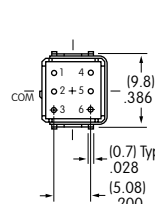
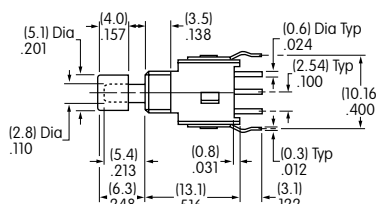
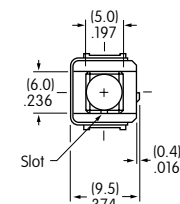

AB25AB-FA

Right Angle PC

Single Pole (Single Throw)

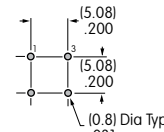
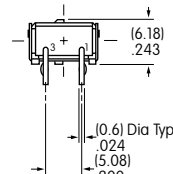
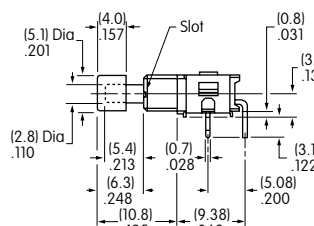
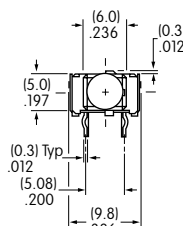

AB11AH-FA

TYPICAL SWITCH DIMENSIONS

Single Pole (Double Throw)

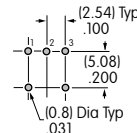
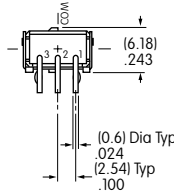
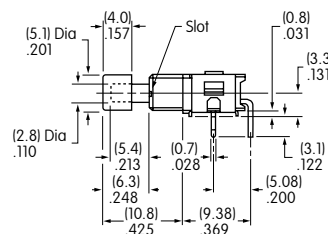
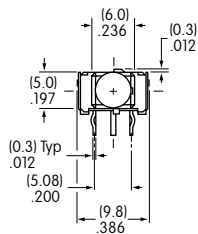

Right Angle PC



AB15AH-FA

Double Pole

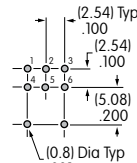
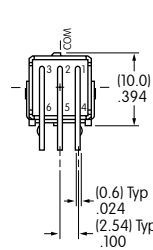
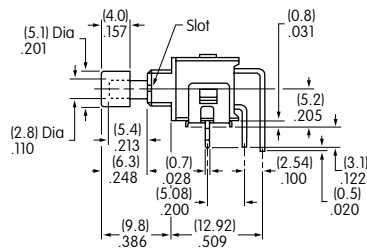
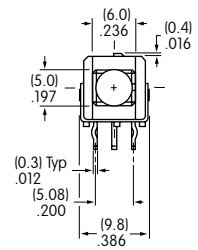

Right Angle PC



AB25AH-FA

Single Pole

Vertical PC • Inline Bracket

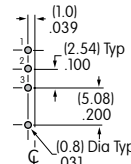
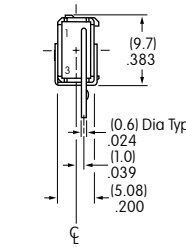
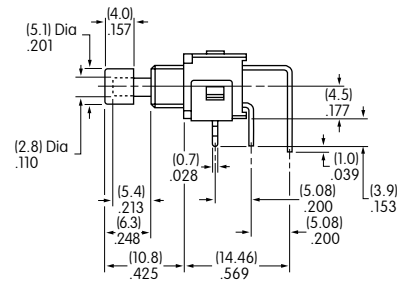
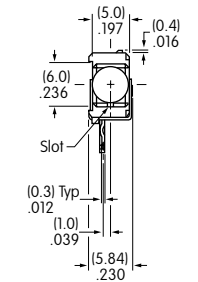

AB11 model does not have terminal 2. **AB11AV1-FA**

Single Pole

Vertical PC

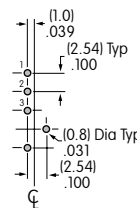
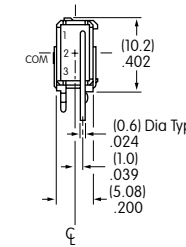
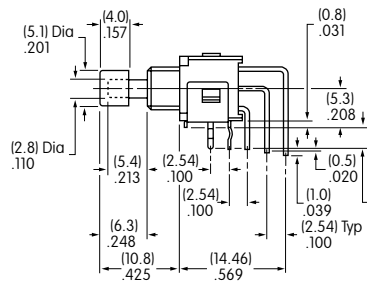
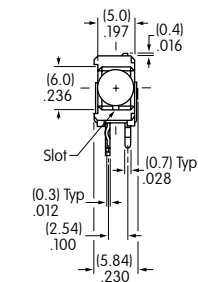

AB11 model does not have terminal 2. **AB15AV-FA**

Double Pole

Vertical PC

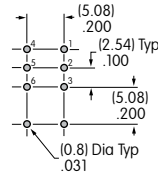
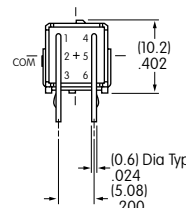
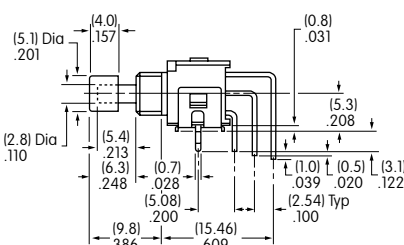
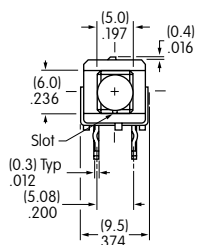

AB25AV-FA

General Specifications

Electrical Capacity (Resistive Load)

Logic Level: 0.4VA maximum @ 28V AC/DC maximum
(Applicable Range 0.1mA ~ 0.1A @ 20mV ~ 28V)
Note: Find additional explanation of operating range in Supplement section.

Other Ratings

Contact Resistance: 50 milliohms maximum

Insulation Resistance: 500 megohms minimum @ 500V DC

Dielectric Strength: 500V AC minimum for 1 minute minimum

Mechanical Life: 50,000 operations minimum (momentary)

25,000 operations minimum (alternate action)

Electrical Life: 50,000 operations minimum (momentary)

25,000 operations minimum (alternate action)

Nominal Operating Force: 2.55N (momentary); 2.94N (alternate action)

Contact Timing: Nonshorting

Travel: Momentary: Pretravel .028" (0.7mm); Overtravel .016" (0.4mm); Total Travel .043" (1.1mm)
Alternate: Pretravel .039" (1.0mm); Overtravel .039" (1.0mm); Total Travel .079" (2.0mm)

Materials & Finishes

Plunger: Polyacetal

Bushing: Carbon blended polyamide

Case Housing: Glass fiber reinforced polyamide

Support Bracket: Tin plated phosphor bronze

Movable Contact: Phosphor bronze with gold plating

Stationary Contacts: Copper alloy with gold plating

Terminals: Copper alloy with gold plating

Environmental Data

Operating Temp Range: -30°C through +85°C (-22°F through +185°F)

Humidity: 90 ~ 95% humidity for 96 hours @ 40°C (104°F)

Vibration: 10 ~ 55Hz with peak-to-peak amplitude of 1.5mm traversing the frequency range & returning in 1 minute; 3 right angled directions for 2 hours

Shock: 50G (490m/s²) acceleration (tested in 6 right angled directions, with 5 shocks in each direction)

Installation

Cap Installation Force: 49.03N (11.2 lbf) maximum downward force on actuator;
actuator must be in UP position to remove cap from alternate action models

PCB Processing

Soldering: Wave Soldering Recommended: See Profile A in Supplement section.

Manual Soldering: See Profile B in Supplement section.

Cleaning: Automated cleaning. See Cleaning specifications in Supplement section.

Standards & Certifications

Flammability Standards: UL94V-0 available

The BB Series pushbuttons have not been tested for UL recognition or CSA certification.

These switches are designed for use in a low-voltage, low-current, logic-level circuit.

When used as intended in a logic-level circuit, the results do not produce hazardous energy.

Distinctive Characteristics

Subminiature size (1/3 size of Series M switches) saves space on PC boards.

Specifically developed for logic-level applications.

Available in momentary and maintained circuits.

Industry's smallest alternate action (maintained) pushbutton with latchdown feature providing visible, audible, and tactile feedback.

Antistatic superstructure, consisting of the carbon impregnated bushing and the support bracket, prevents static discharge to the contacts. Static electricity from an operator's touch travels from the actuator through the bushing and bracket to the PC board.

Award-winning STC contact mechanism with benefits unavailable in conventional mechanisms: smoother, positive detent actuation, increased contact stability and unparalleled logic-level reliability. (Additional STC details in Terms & Acronyms; see Supplement section.)

Smooth, 6mm diameter bushing simplifies panel layout.

Totally sealed body construction prevents contact contamination and allows time- and money-saving soldering and cleaning.

.100" x .100" (2.54mm x 2.54mm) terminal spacing conforms to standard PC board grids.

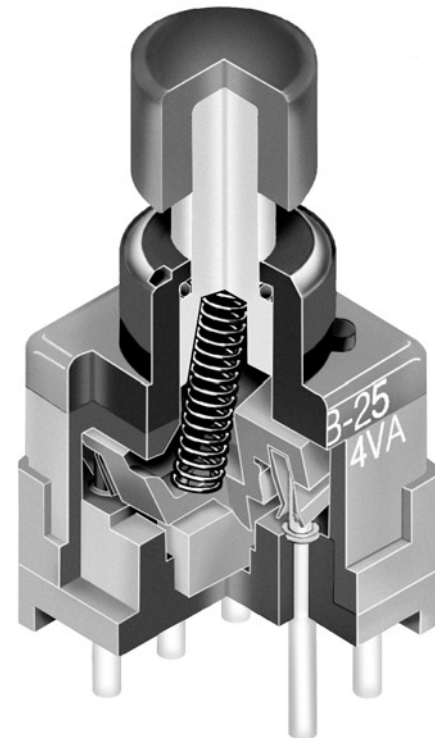

Actual Size

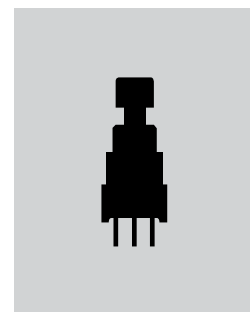

- Toggles
- Rockers
- Pushbuttons**
- Illuminated PB
- Programmable
- Keylocks
- Rotaries
- Slides
- Tactiles
- Tilt
- Touch
- Indicators
- Accessories
- Supplement

TYPICAL SWITCH ORDERING EXAMPLE

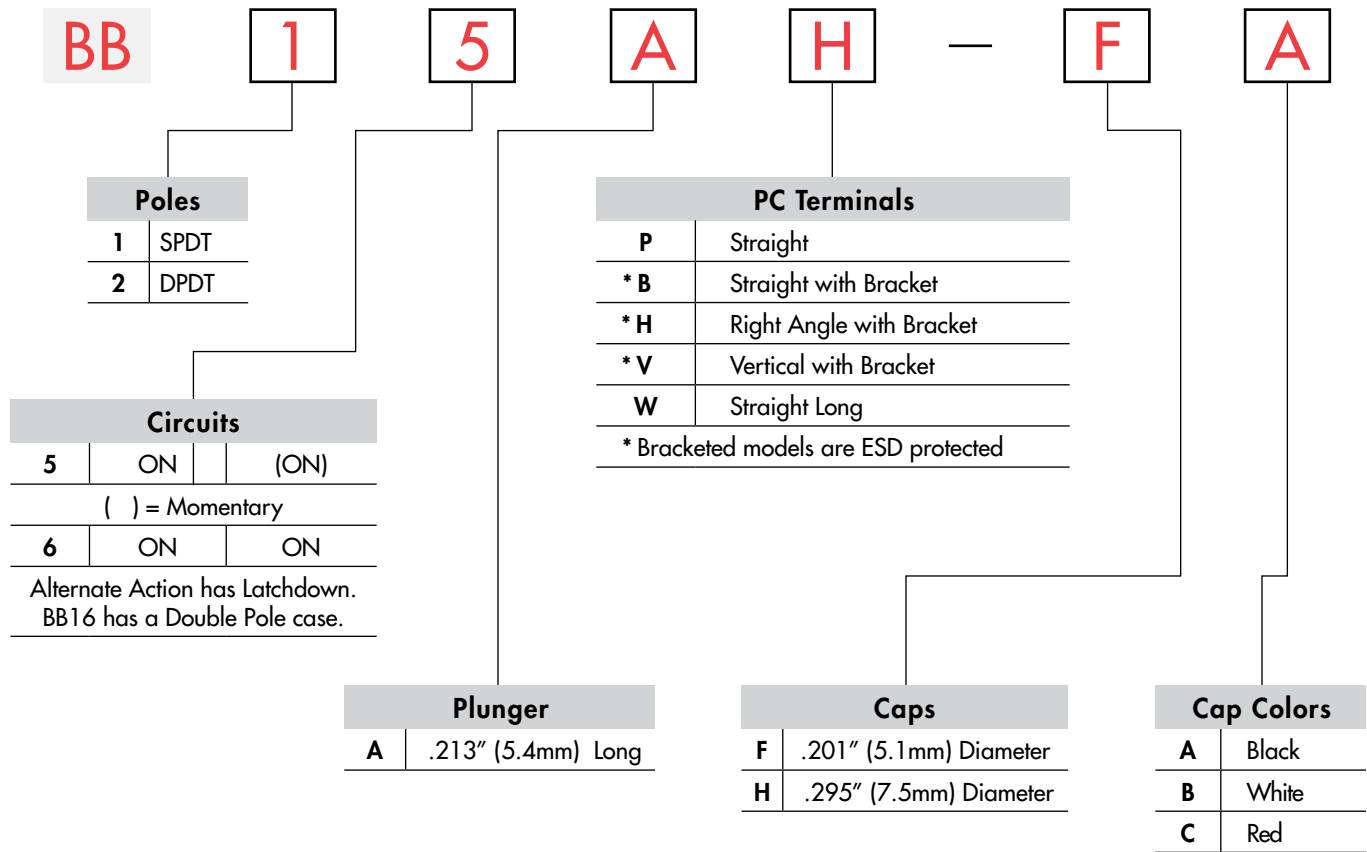

DESCRIPTION FOR TYPICAL ORDERING EXAMPLE

BB15AH-FA

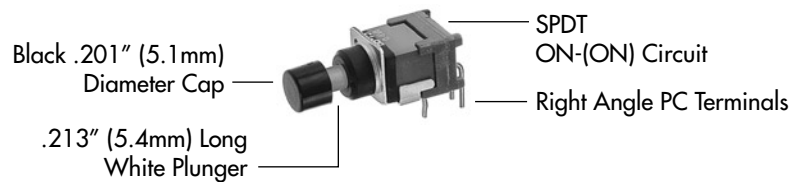

Toggles
 Rockers
 Pushbuttons
 Illuminated PB
 Programmable
 Keylocks
 Rotaries
 Slides
 Tactiles
 Tilt
 Touch
 Indicators
 Accessories
 Supplement

POLES & CIRCUITS

Pole	Model	Plunger Position () = Momentary		Connected Terminals		Throw & Schematics
		Normal	Down	Normal	Down	
SP	BB15 BB16	ON ON	(ON) ON	2-3	2-1	SPDT
DP	BB25 BB26	ON ON	(ON) ON	2-3 5-6	2-1 5-4	DPDT

PLUNGERS

A .213" (5.4mm) Long

Standard Plunger Color: White

Contact factory for other colors and lengths.

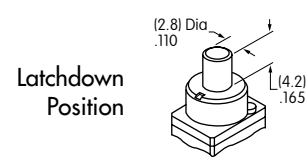
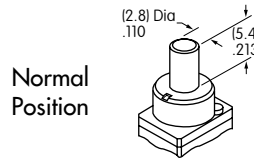

PC TERMINALS

Use of a support bracket is recommended to increase PCB mounting strength and stability.

Both single pole and double pole alternate action models have double pole bases.

See Typical Switch Dimensions for details.

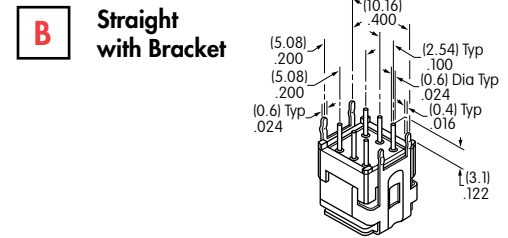
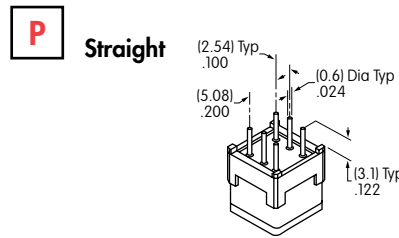

H Right Angle with Bracket

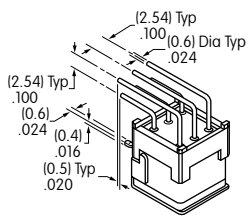

V Vertical with Bracket

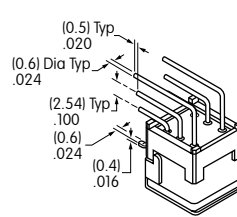

W Straight Long

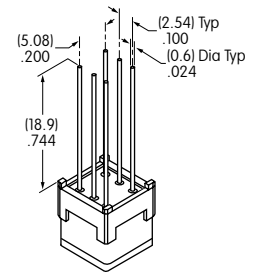

SLIP-ON CAPS

F AT475
.201" (5.1mm) Diameter Cap



Material: Polyamide

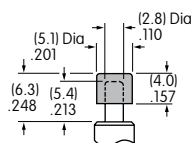

H AT496
.295" (7.5mm) Diameter Cap



Material: Polyamide

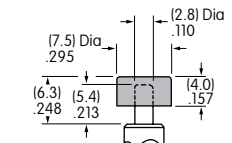

Colors Available:

A Black

B White

C Red

TYPICAL SWITCH DIMENSIONS

Straight PC

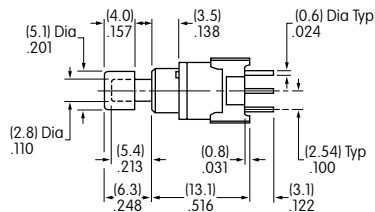
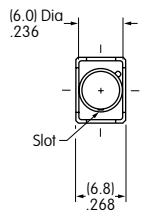

Single Pole

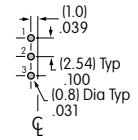
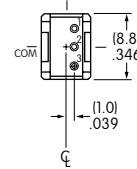

BB15AP-FA

Momentary

Straight PC

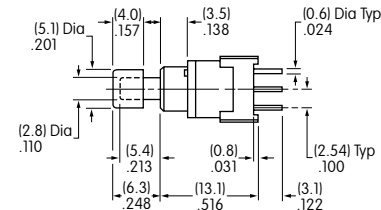
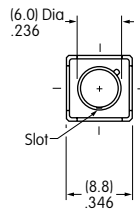

Double Pole

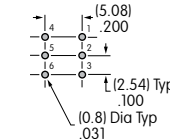
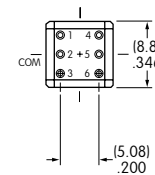

BB16AP

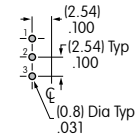
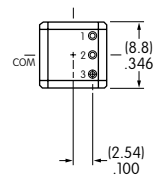

BB25AP-FA

Momentary & Alternate

Alternate

Straight PC • Bracket

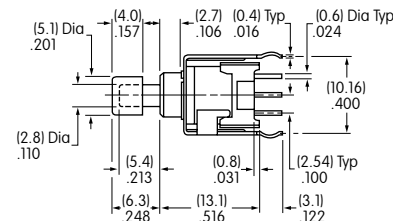
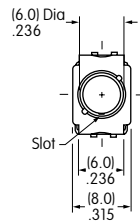

Single Pole

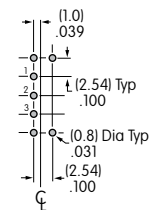
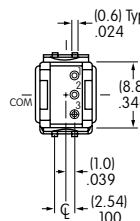

BB15AB-FA

Momentary

Straight PC • Bracket

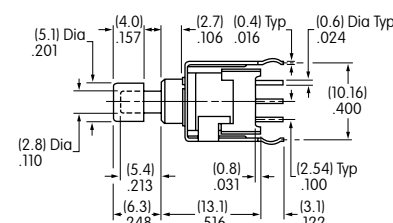
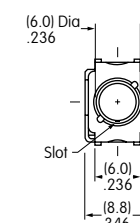

Double Pole

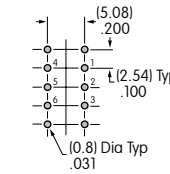
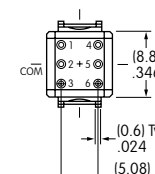

BB16AB

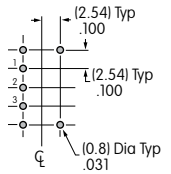
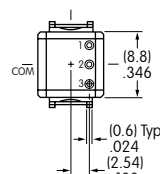

BB25AB-FA

Momentary & Alternate

Alternate

Toggles
Rockers
Pushbuttons
Illuminated PB
Programmable
Keylocks
Rotaries
Slides
Tactiles
Tilt
Touch
Indicators
Accessories
Supplement

TYPICAL SWITCH DIMENSIONS

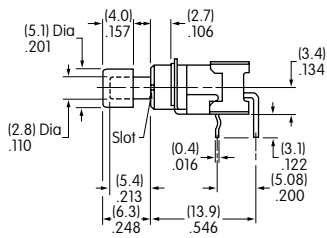
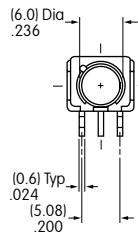

Single Pole

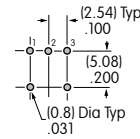
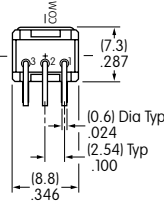

Momentary

Right Angle PC



BB15AH-FA

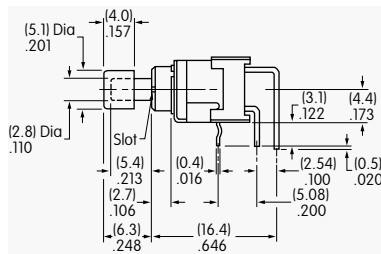
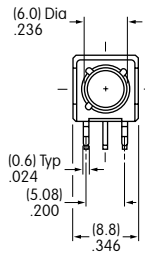

Double Pole

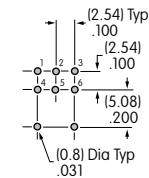
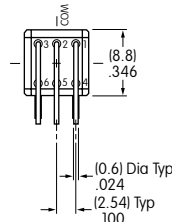

Momentary & Alternate

BB16AH

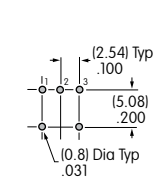
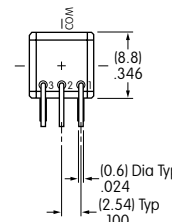

Alternate

Right Angle PC



BB25AH-FA

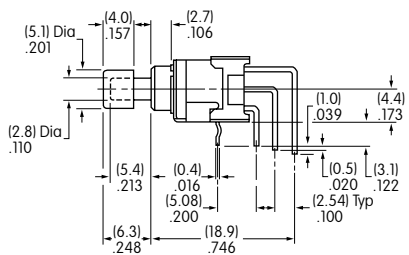
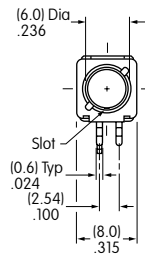

Single Pole

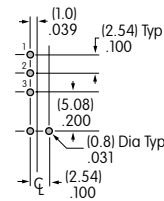
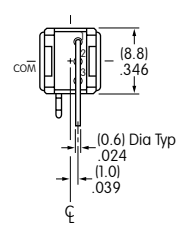

Momentary

Vertical PC



BB15AV-FA

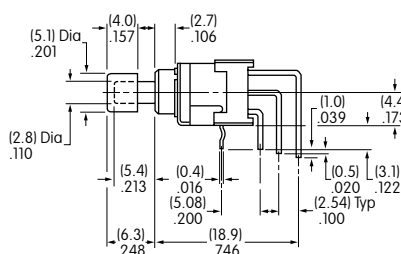
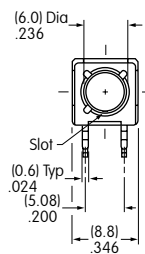

Double Pole

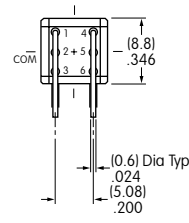

Momentary & Alternate

BB16AV

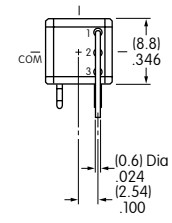

Alternate

Vertical PC



BB25AV-FA

General Specifications

Electrical Capacity (Resistive Load)

Logic Level: 0.4VA maximum @ 28V AC/DC maximum
(Applicable Range 0.1mA ~ 0.1A @ 20mV ~ 28V)
Note: Find additional explanation of operating range in Supplement section.

Other Ratings

Contact Resistance: 50 milliohms maximum
Insulation Resistance: 1,000 megohms minimum @ 500V DC
Dielectric Strength: 1,000V AC minimum between contacts for 1 minute minimum;
1,500V AC minimum between contacts & case for 1 minute minimum

Mechanical Life: 200,000 operations minimum
Electrical Life: 100,000 operations minimum
Nominal Operating Force: Single Pole: 1.96N
Double Pole: 2.94N
Travel: Pretravel .020" (0.5mm); Overtravel .020" (0.5mm); Total Travel .039" (1.0mm)

Materials & Finishes

Plunger: Brass with nickel plating
Bushing: Brass with nickel plating
Frame: Stainless steel
Case: Glass fiber reinforced polyamide
Movable Contacts: Copper with gold plating
Stationary Contacts: Phosphor bronze with gold plating
Terminals: Brass with gold plating

Environmental Data

Operating Temp Range: -10°C through +70°C (+14°F through +158°F)
Humidity: 90 ~ 95% humidity for 96 hours @ 40°C (104°F)
Vibration: 10 ~ 55Hz with peak-to-peak amplitude of 1.5mm traversing the frequency range & returning in 1 minute; 3 right angled directions for 2 hours
Shock: 50G (490m/s²) acceleration (tested in 6 right angled directions, with 5 shocks in each direction)

Installation

Mounting Torque: 1.47Nm (13.0 lb•in) for double nut; 0.68Nm (6.0 lb•in) for single nut
Cap Installation Force: 78.5N (17.65 lbf) maximum downward force on actuator

PCB Processing

Soldering: Wave Soldering Recommended. See Profile A in Supplement section.
Manual Soldering: See Profile B in Supplement section.
Cleaning: These devices are not process sealed. Hand clean locally using alcohol based solution.

Standards & Certifications

The DB Series pushbuttons have not been tested for UL recognition or CSA certification. These switches are designed for use in low-voltage, low-current, logic-level circuit. When used as intended in a logic-level circuit, the results do not produce hazardous energy.

Distinctive Characteristics

Both PCB and panel mounting options available.

Choice of cap sizes in .315" (8.0mm) and .394" (10.0mm) diameter cap design for simple, snap-on installation.

High torque bushing prevents rotation and separation from metal frame during installation.

Stainless steel frame resists corrosion.

Snap action contacts give smooth actuation, short stroke, light touch, and audible feedback. This mechanism also provides long mechanical life.

Molded-in terminals prevent entry of solder flux, dust, and other contaminants.

.100" x .100" (2.54mm x 2.54mm) terminal spacing conforms to standard PC board grid spacing. Round terminals for easier through-hole mounting on PC boards.

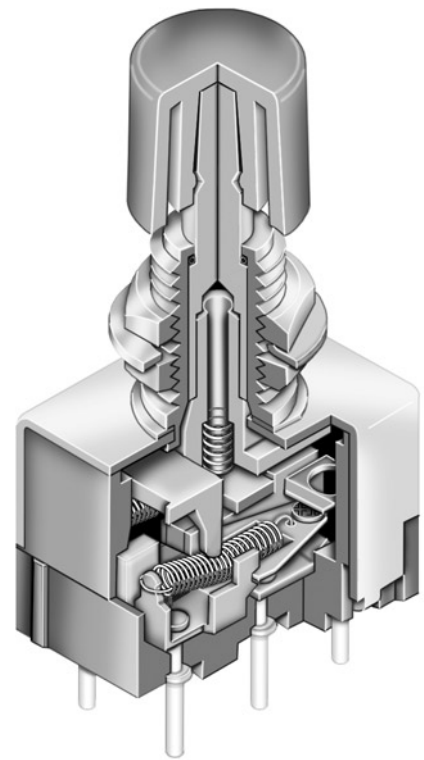

Actual Size

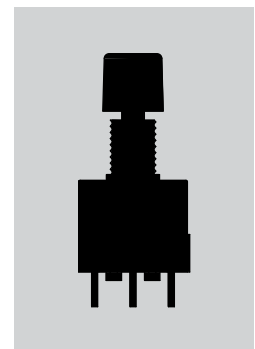

- Supplement
- Accessories
- Indicators
- Touch
- Tilt
- Tactiles
- Slides
- Rotaries
- Keylocks
- Programmable
- Illuminated PB
- Pushbuttons
- Rockers
- Toggles

TYPICAL SWITCH ORDERING EXAMPLE

DB25

21

B

Poles & Circuits

11	SPDT	ON	(ON)
21	DPDT	ON	(ON)

() = Momentary

PC Terminals

Threaded Bushing	
P	Straight
Smooth Bushing	
B	Straight with Bracket
H	Right Angle with Bracket
V	Vertical with Bracket

DESCRIPTION FOR TYPICAL ORDERING EXAMPLE

DB2521B with AT443E Cap

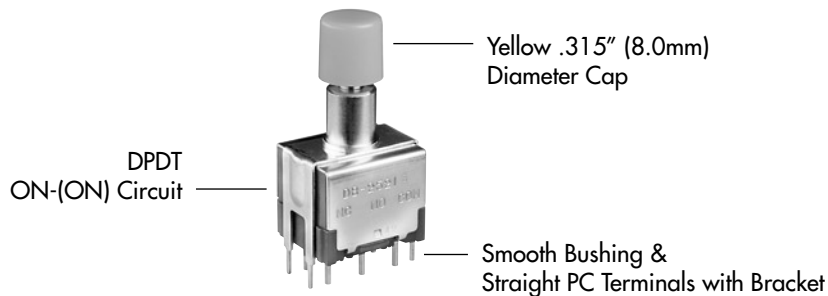

POLES & CIRCUITS

		Plunger Position () = Momentary		Connected Terminals		Throw & Switch Schematics
Pole	Model	Normal 	Down 	Normal 	Down 	
SP	DB2511	ON	(ON)	3-1	3-2	SPDT
DP	DB2521	ON	(ON)	3-1 6-4	3-2 6-5	DPDT

TYPICAL SWITCH DIMENSIONS

Single Pole

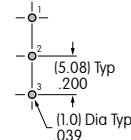
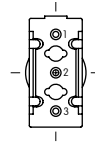
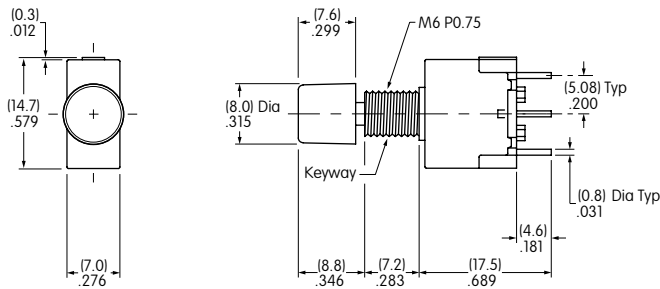

Straight PC



DB2511P with AT443C

Double Pole

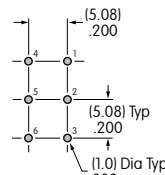
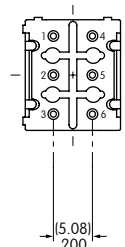
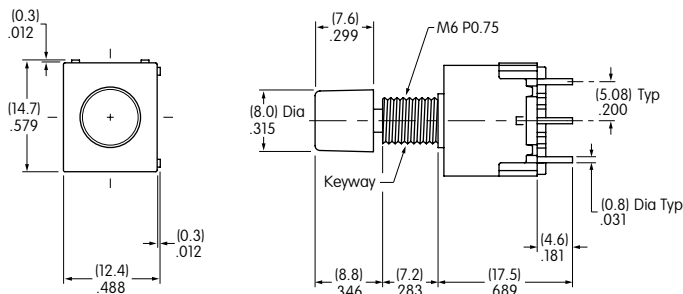

Straight PC



DB2521P with AT442A

Single Pole

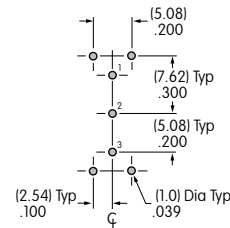
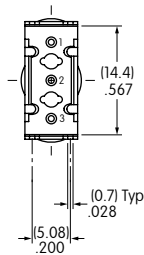
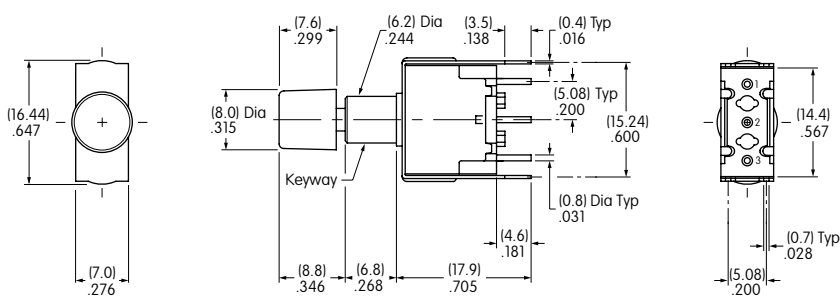

Straight PC with Bracket



DB2511B with AT442C

Double Pole

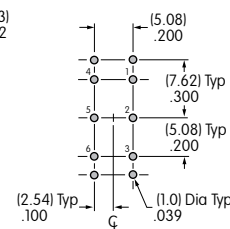
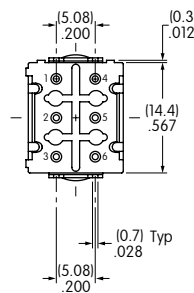
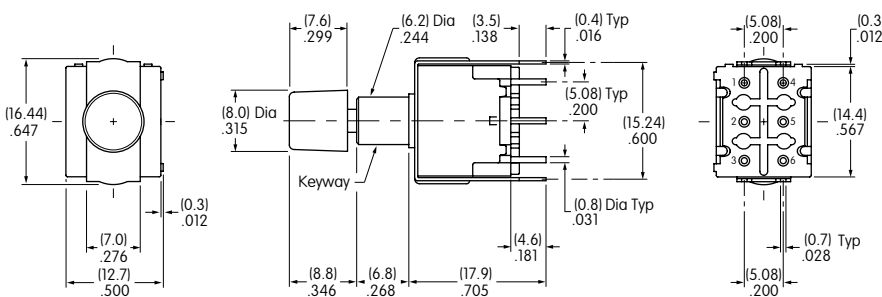

Straight PC with Bracket



DB2521B with AT443E

TYPICAL SWITCH DIMENSIONS

Right Angle PC with Bracket

Single Pole

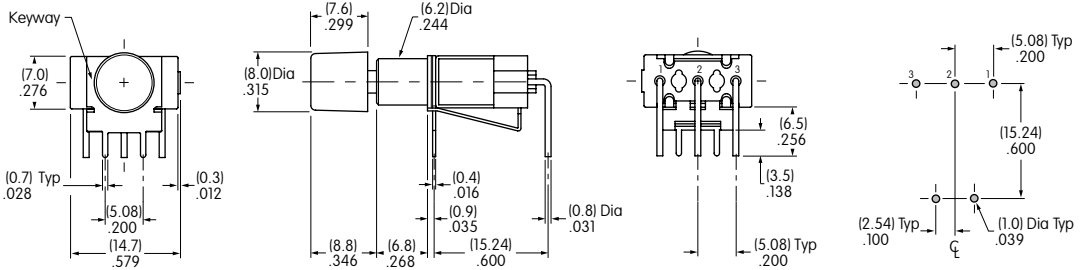
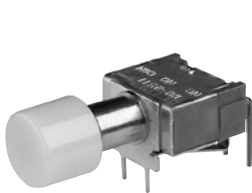

DB2511H with AT442B

Right Angle PC with Bracket

Double Pole

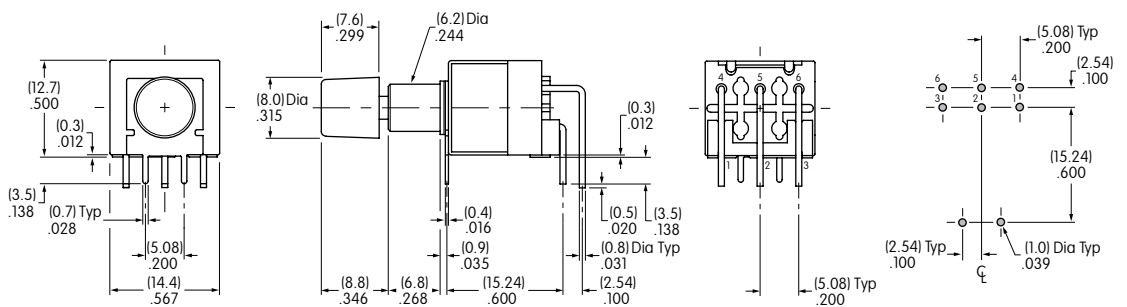

DB2521H with AT442A

Vertical PC with Bracket

Single Pole

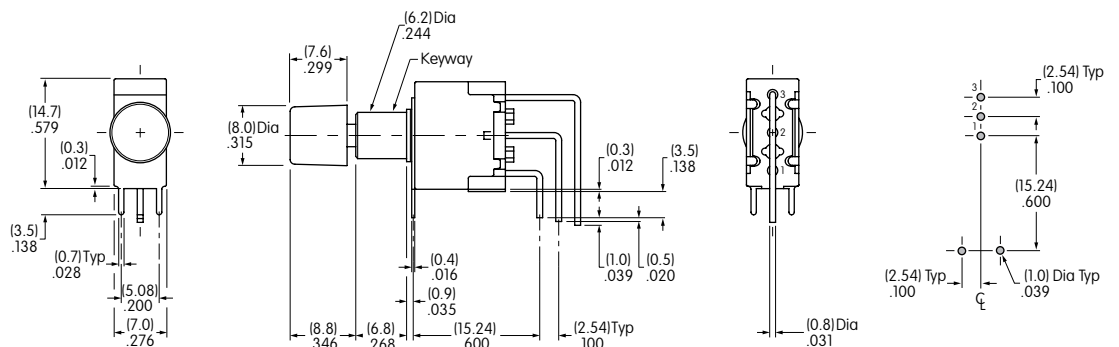
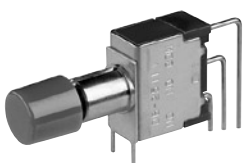

DB2511V with AT443C

Vertical PC with Bracket

Double Pole

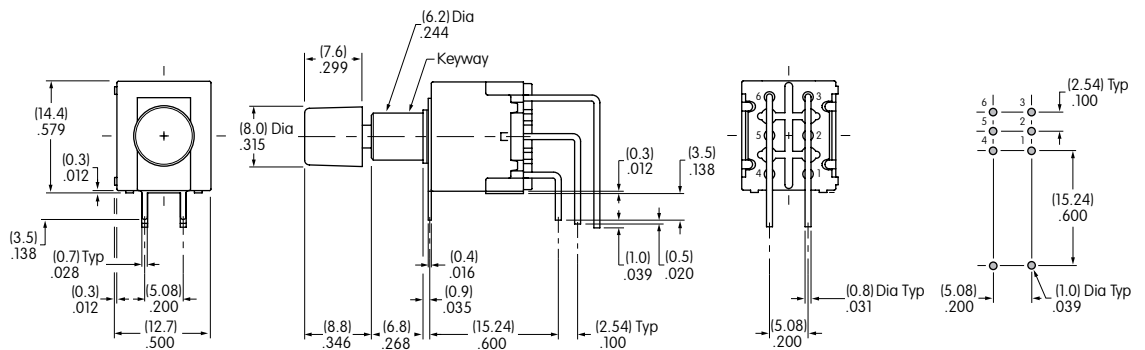
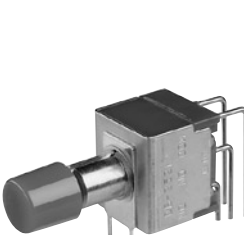

DB2521V with AT443C

OPTIONAL CAPS & COLORS

AT443 .315" (8.0mm) Diameter Snap-on Cap

Cap Colors Available:

- | | |
|----------------|-----------------|
| A Black | E Yellow |
| B White | F Green |
| C Red | G Blue |

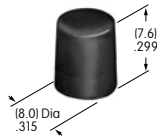

Cap Material: Polycarbonate Finish: Glossy

AT442 .394" (10.0mm) Diameter Snap-on Cap

Cap Colors Available:

- | | |
|----------------|-----------------|
| A Black | E Yellow |
| B White | F Green |
| C Red | G Blue |

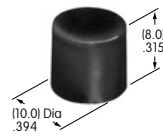

Cap Material: Polycarbonate Finish: Glossy

HARDWARE

Standard Hardware

AT513M Metric Hexagon Nut

Material:
Brass with
Nickel Plating

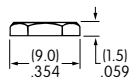
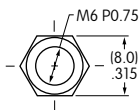

AT509 Lockwasher

Material:
Steel with
Zinc/Chromate

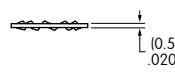
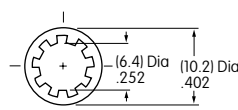

Optional Hardware

AT507M Metric Locking Ring

Material:
Steel with
Zinc/Chromate

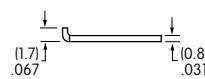
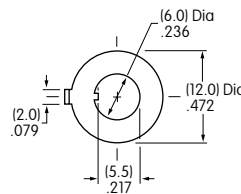

AT501M Metric Knurled Face Nut

Material:
Brass with
Chrome Plating

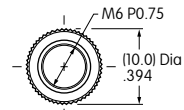

INSTALLATION/ASSEMBLY

- 2 AT513M Metric Hexagon Nuts
- 1 AT509 Internal Tooth Lockwasher

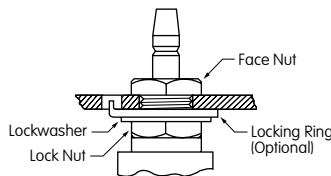

Optional Hardware:
AT507M Metric Locking Ring

Note: Cap must be snapped on after the switch is mounted into the panel.

PANEL CUTOUTS & THICKNESSES

With Standard Hardware

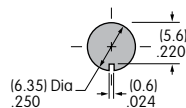

Maximum Effective Panel Thickness:
.118" (3.0mm)

Without Bottom Hex Nut

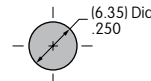

Maximum Effective Panel Thickness:
.185" (4.7mm)

With Standard Hardware & Optional Locking Ring

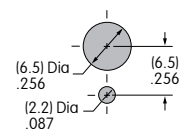

Maximum Effective Panel Thickness:
.087" (2.2mm)

General Specifications

Electrical Capacity (Resistive Load)

Power Level (silver):	3A @ 125V AC for silver contacts
Logic Level (gold):	0.4VA maximum @ 28V AC/DC maximum for gold contacts (Applicable Range 0.1mA ~ 0.1A @ 20mV ~ 28V) Note: Find additional explanation of operating range in Supplement section.

Other Ratings

Contact Resistance:	10 milliohms maximum for silver; 20 milliohms maximum for gold
Insulation Resistance:	1,000 megohms minimum @ 500V DC
Dielectric Strength:	1,000V AC minimum between contacts for 1 minute minimum; 1,500V AC minimum between contacts and case for 1 minute minimum
Mechanical Life:	100,000 operations minimum
Electrical Life:	25,000 operations minimum for silver; 50,000 operations minimum for gold
Nominal Operating Force:	Single Pole: 2.35N for Momentary and 2.65N for Alternate Action Double Pole: 2.94N for Momentary and 3.63N for Alternate Action
Travel:	Momentary: Pretravel .047" (1.2mm); Overtravel .016" (0.4mm); Total Travel .063" (1.6mm) Alternate: Pretravel .071" (1.8mm); Overtravel .016" (0.4mm); Total Travel .087" (2.2mm)

Materials & Finishes

Plunger:	Brass with chrome plating for Momentary; brass with nickel plating for Alternate
Bushing:	Brass with nickel plating
Frame:	Stainless steel
Case:	Melamine phenolic resin (UL94V-0)
Movable Contacts:	Copper with silver or gold plating
Stationary Contacts:	Silver with silver or gold plating
Terminals:	Copper with silver or gold plating

Environmental Data

Operating Temp Range:	-10°C through +70°C (+14°F through +158°F)
Humidity:	90 ~ 95% humidity for 96 hours @ 40°C (104°F)
Vibration:	10 ~ 55Hz with peak-to-peak amplitude of 1.5mm traversing the frequency range & returning in 1 minute; 3 right angled directions for 2 hours
Shock:	50G (490m/s ²) acceleration (tested in 6 right angled directions, with 5 shocks in each direction)

Installation

Mounting Torque:	1.47Nm (13.0 lb•in) for double nut; 0.68Nm (6.0 lb•in) for single nut
Cap Installation Force:	78.5N (17.65 lbf) maximum downward force on actuator
Soldering Time & Temp:	Wave Solder (Straight PC): See Profile B in Supplement section. Manual Soldering: See Profile B in Supplement section.
Cleaning:	These devices are not process sealed. Hand clean locally using alcohol based solution.

Standards & Certifications

Flammability Standards:	UL94V-0 case
UL:	File No. E44145 - Recognized only when ordered with marking on switch. Add "/U" or "/CUL" before first dash in part number to order UL recognized switch. All single and double pole models recognized at 3A @ 125V AC.
CSA:	File No. 023535_0_000 - Certified only when ordered with marking on switch. Add "/C" before first dash in part number to order CSA certified switch. Single pole solder lug and PC models certified at 3A @ 125V AC; double pole PC models certified at 3A @ 125V AC.

Distinctive Characteristics

Power and logic level capabilities available to suit varying applications.

Bushing and snap-in mount versions available; snap-in models offer many style and color choices to enhance front panel appearance.

Light touch actuation.

High torque bushing prevents rotation and separation from metal frame during installation.

Stainless steel frame resists corrosion.

Case of heat resistant resin meets UL 94V-0 flammability rating.

Higher insulating barriers protect against crossover in double pole devices.

1,500V dielectric strength between contacts and case is accomplished by clinching the frame away from the terminals.

Epoxy sealed terminals prevent entry of solder flux and other contaminants.

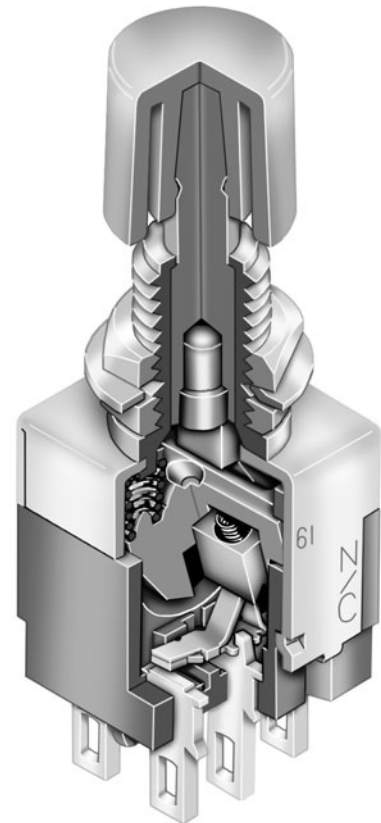

Actual Size

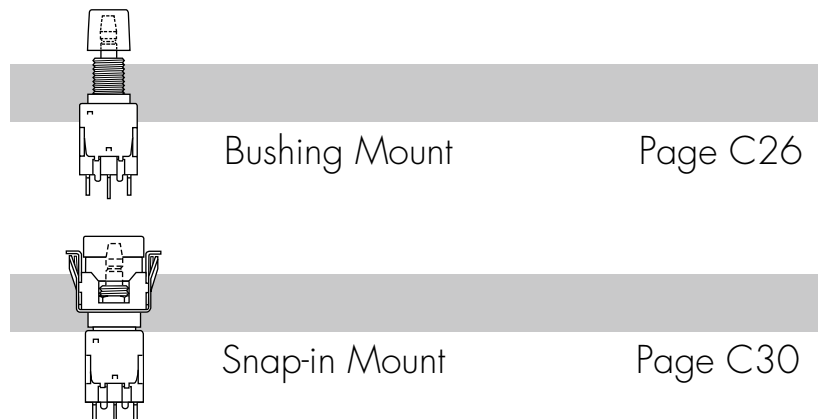
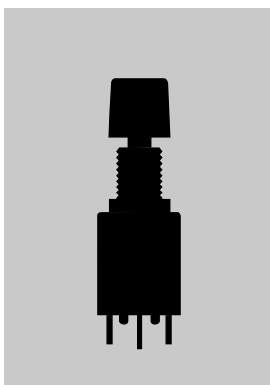

Supplement
Accessories
Indicators
Touch
Tilt
Tactiles
Slides
Rotaries
Keylocks
Programmable
Illuminated PB
Pushbuttons
Rockers
Toggles

TYPICAL SWITCH ORDERING EXAMPLE

EB20

65

B

F

Poles & Circuits

11	SPDT	ON	(ON)
65	SPDT	ON	ON
61	DPDT	ON	(ON)
85	DPDT	ON	ON

() = Momentary

Caps

B	.315" (8.0mm) Dia.
C	.394" (10.0mm) Dia.

Contacts, Ratings, & Terminals

No Code	Silver Contacts; Solder Lug Terminals* 3A @ 125V AC
G	Gold Contacts; Solder Lug Terminals* 0.4VA max @ 28V AC/DC max
P	Silver Contacts; Straight PC Terminals; 3A @ 125V AC
PG	Gold Contacts; Straight PC Terminals 0.4VA max @ 28V AC/DC max

Colors

A	Black
B	White
C	Red
E	Yellow
F	Green
G	Blue
H	Gray

IMPORTANT:



Switches are supplied without UL, cULus & CSA marking unless specified. **UL, cULus & CSA recognized only when ordered with marking on the switch.** Specific models, ratings, & ordering instructions are noted on General Specifications page.



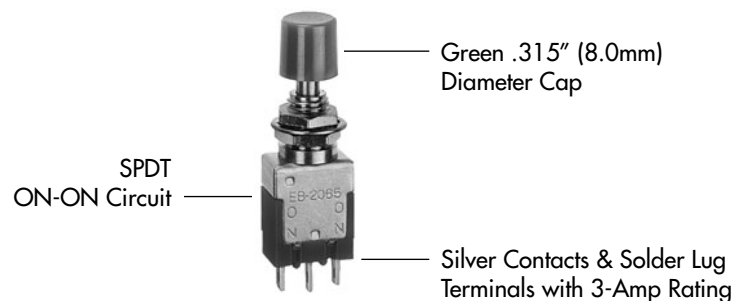

* Wire harness & cable assemblies offered only in Americas

DESCRIPTION FOR TYPICAL ORDERING EXAMPLE

EB2065-BF

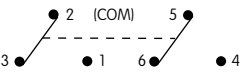

POLES & CIRCUITS

Pole	Model	Plunger Position () = Momentary		Connected Terminals		Throw & Switch Schematics
		Normal  Keyway	Down 	Normal  Keyway	Down 	
SP	EB2011 EB2065	ON ON	(ON) ON	2-3	2-1	SPDT 
DP	EB2061 EB2085	ON ON	(ON) ON	2-3 5-6	2-1 5-4	DPDT 

CONTACT MATERIALS, RATINGS, & TERMINALS



**Solder Lug
Silver Contacts**

Power Level

3A @ 125V AC



**Solder Lug
Gold Contacts**

Logic Level

0.4VA max @ 28V AC/DC max

Complete explanation of operating range in Supplement section.

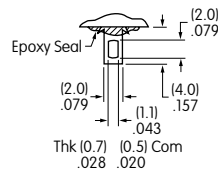

**Straight PC
Silver Contacts**

Power Level

3A @ 125V AC



**Straight PC
Gold Contacts**

Logic Level

0.4VA max @ 28V AC/DC max

Complete explanation of operating range in Supplement section.

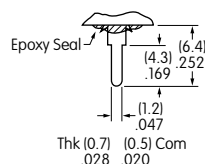

PCB Footprints

Single Pole

Double Pole

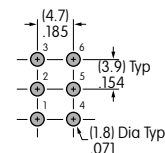
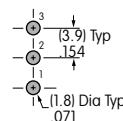

CAPS & COLORS

B AT443
.315" (8.0mm) Diameter Snap-on Cap

C AT442
.394" (10.0mm) Diameter Snap-on Cap

Cap Colors Available:

- | | |
|-----------------|----------------|
| A Black | F Green |
| B White | G Blue |
| C Red | H Gray |
| E Yellow | |

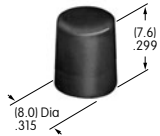

Cap Colors Available:

- | | |
|-----------------|----------------|
| A Black | F Green |
| B White | G Blue |
| C Red | H Gray |
| E Yellow | |

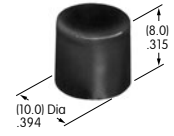

Cap Material: Polycarbonate Finish: Glossy

Cap Material: Polycarbonate Finish: Glossy

Plunger Extension

Due to a difference in plunger lengths on the momentary and alternate action models, cap distance from top of bushing varies.

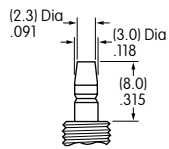

Momentary Plunger Length

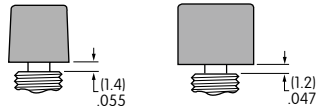

Momentary Cap Location

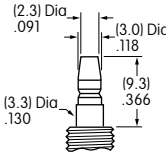

Alternate Plunger Length

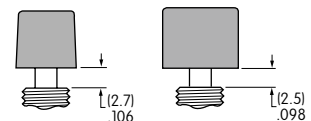

Alternate Cap Location

TYPICAL SWITCH DIMENSIONS

Solder Lug

Single Pole



EB2011-BA

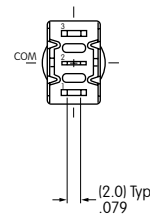
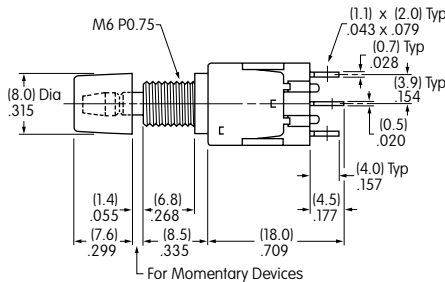
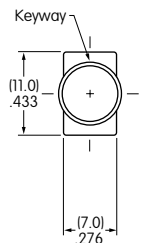

Solder Lug

Double Pole



EB2061-BA

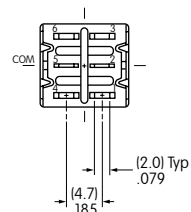
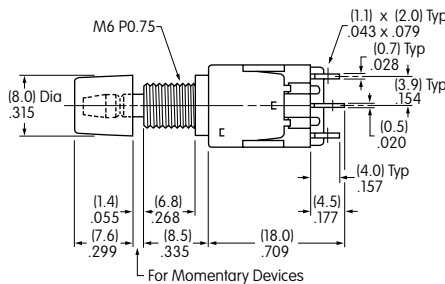
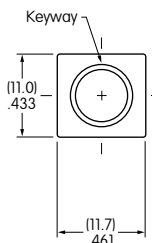

HARDWARE

Installation/Assembly

- 2 AT513M Metric Hexagon Nuts
- 1 AT509 Internal Tooth Lockwasher

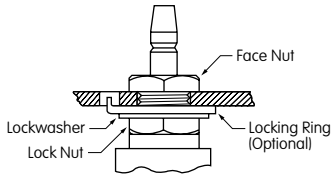

Optional Hardware:
AT507M Metric Locking Ring

Note: Cap must be snapped on after the switch is mounted into the panel.

Standard Hardware

AT513M Metric Hexagon Nut

Material:
Brass with
Nickel Plating

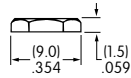
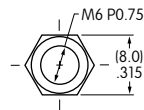

AT509 Lockwasher

Material:
Steel with
Zinc/Chromate

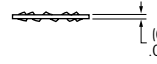
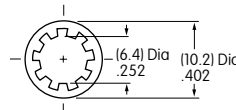

Optional Hardware

AT507M Metric Locking Ring

Material:
Steel with
Zinc/Chromate

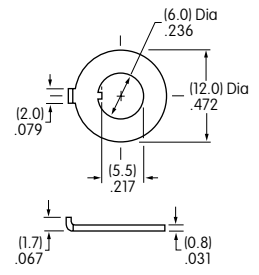

PANEL CUTOUTS & THICKNESSES

Metric Bushing

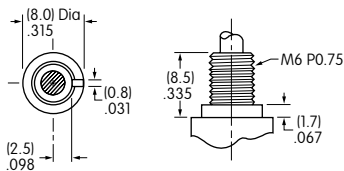

With Standard Hardware

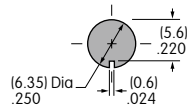

Maximum Effective
Panel Thickness:
.118" (3.0mm)

With Standard Hardware & Optional Locking Ring

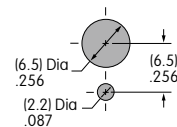

Maximum Effective
Panel Thickness:
.055" (1.4mm)

Without Bottom Hex Nut

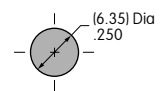

Maximum Effective
Panel Thickness:
.185" (4.7mm)

See Accessories & Hardware section for optional Conical Nuts:
AT512M used with cap AT443 and AT512CM used with cap AT442.

TYPICAL SWITCH ORDERING EXAMPLES

EB20

11

B

J23

Poles & Circuits

11	SPDT	ON	(ON)
65	SPDT	ON	ON
61	DPDT	ON	(ON)
85	DPDT	ON	ON

() = Momentary

Contacts, Ratings, & Terminals

No Code	Silver Contacts; Solder Lug Terminals* 3A @ 125V AC
G	Gold Contacts; Solder Lug Terminals* 0.4VA max @ 28V AC/DC max
P	Silver Contacts; Straight PC Terminals; 3A @ 125V AC
PG	Gold Contacts; Straight PC Terminals 0.4VA max @ 28V AC/DC max

Cap Colors

A	Black
B	White
C	Red
E	Yellow
F	Green
G	Blue
H	Gray

Cap Extensions & Bezel Types

Low Rise		High Rise		Description
Momentary	Alternate	Momentary	Alternate	
J20	J30	J40	J50	Without Bezel
J21	J31	J41	J51	Bezel without LED
J22	J32	J42	J52	Bezel with 1 Round LED
J23	J33	J43	J53	Bezel with 2 Round LEDs
J24	J34	J44	J54	Bezel with 2 Rectangular LEDs

Bezel Colors

Bezel without LEDs			
A	Black	F	Green
B	White	G	Blue
C	Red	H	Gray
E	Yellow		

Bezel with 1 Round LED	
A	Black

Bezel with 2 Round or Rectangular LEDs			
A	Black		

Led Colors

1 LED	
C	Red
F	Green

2 LEDs			
Top LED		Bottom LED	
C	Red	C	Red
E	Yellow	E	Yellow
F	Green	F	Green

IMPORTANT:

Switches are supplied without UL, cULus & CSA marking unless specified. **UL, cULus & CSA recognized only when ordered with marking on the switch.** Specific models, ratings, & ordering instructions are noted on General Specifications page.

* Wire harness & cable assemblies offered only in Americas

DESCRIPTION FOR TYPICAL ORDERING EXAMPLE WITHOUT BEZEL

EB2011-A-J40

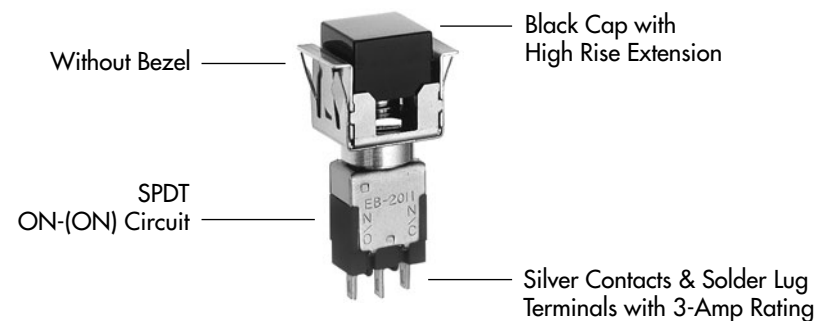

DESCRIPTION FOR TYPICAL ORDERING EXAMPLE WITH BEZEL

EB2011-B-J23ACF

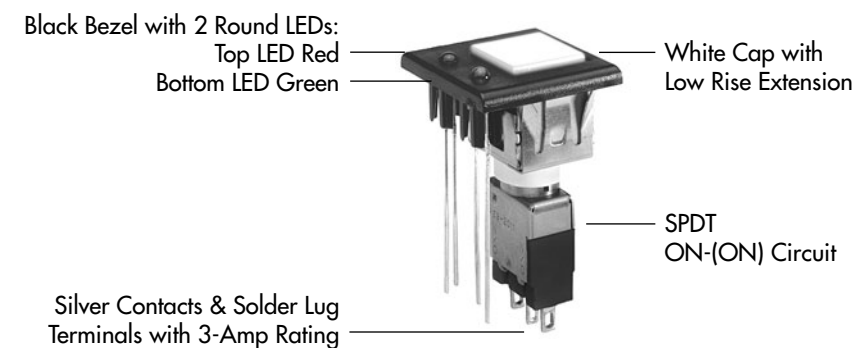

Toggles

Rockers

Pushbuttons

Illuminated PB

Programmable

Keylocks

Rotaries

Slides

Tactiles

Tilt





Touch

Indicators

Accessories

Supplement

POLES & CIRCUITS

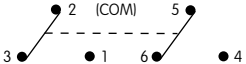
		Plunger Position () = Momentary		Connected Terminals		Throw & Switch Schematics
Pole	Model	Normal 	Down 	Normal 	Down 	Note: Terminal numbers are not actually on the switch.
SP	EB2011 EB2065	ON ON	(ON) ON	2-3	2-1	SPDT 
DP	EB2061 EB2085	ON ON	(ON) ON	2-3 5-6	2-1 5-4	DPDT 

CONTACT MATERIALS, RATINGS, & TERMINALS



**Solder Lug
Silver Contacts**

Power Level

3A @ 125V AC



**Solder Lug
Gold Contacts**

Logic Level

0.4VA maximum @ 28V AC/DC maximum

Complete explanation of operating range in Supplement section.

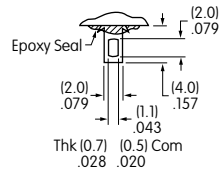

**Straight PC
Silver Contacts**

Power Level

3A @ 125V AC



**Straight PC
Gold Contacts**

Logic Level

0.4VA maximum @ 28V AC/DC maximum

Complete explanation of operating range in Supplement section.

PCB Footprints

Single Pole

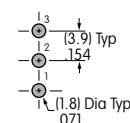

Double Pole

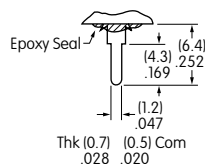
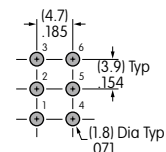

CAP COLORS

Factory Assembled on the Switch:
 Square snap-on cap AT465, snap-in moulder
 AT529, and optional bezels which follow.

- | | | | |
|----------------|----------------|---------------|-----------------|
| A Black | B White | C Red | E Yellow |
| F Green | G Blue | H Gray | |

CAP EXTENSIONS & BEZEL TYPES

Cap Extension without Bezel

J20

Low Rise Momentary

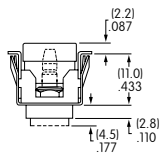

J30

Low Rise Alternate

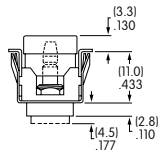

J40

High Rise Momentary

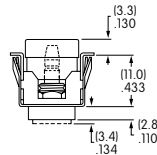

J50

High Rise Alternate

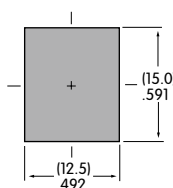
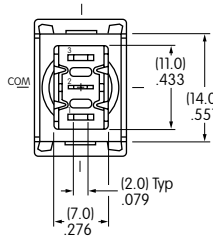
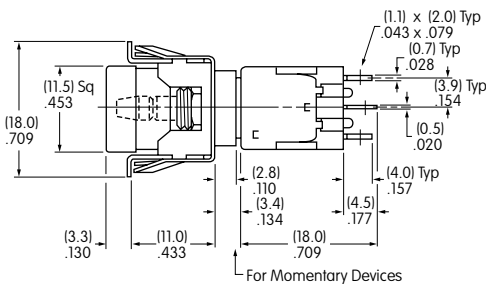
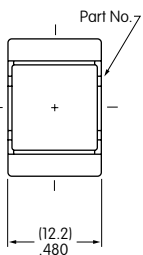
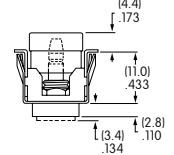

Maximum Panel Thickness
 .039" ~ .157" (1.0mm ~ 4.0mm)
 Cutout applies to SP & DP



High Rise

Single Pole

EB2011-A-J40

Cap Extension with Bezel

J21

Low Rise Momentary

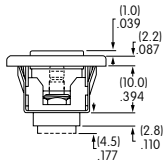

J31

Low Rise Alternate

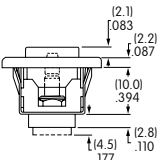

J41

High Rise Momentary

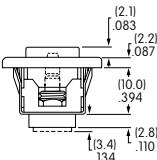

J51

High Rise Alternate

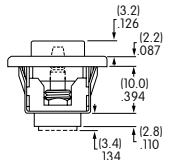

AT207 Bezel without LED

- | | | | |
|-----------------|----------------|----------------------------|-------------------|
| E Yellow | F Green | Material:
Polycarbonate | |
| A Black | G Blue | | |
| B White | H Gray | | Finish:
Glossy |
| C Red | | | |

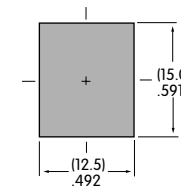
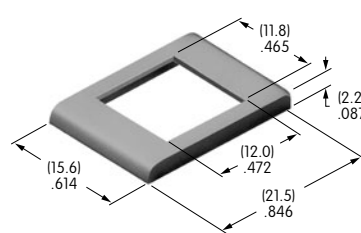

Maximum Panel Thickness
 .039" ~ .126" (1.0mm ~ 3.2mm)
 Cutout applies to SP & DP

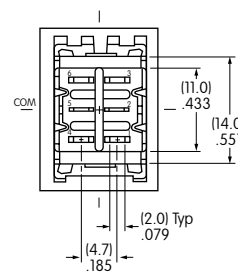
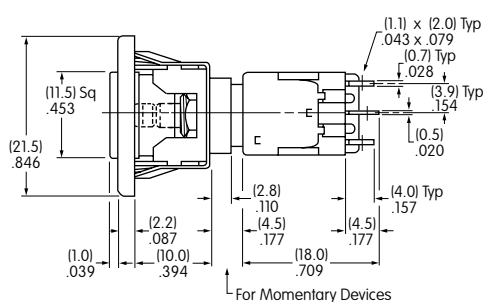
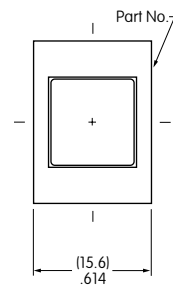

Low Rise

Double Pole

EB2061-B-J21A

CAP EXTENSIONS & BEZEL TYPES

Cap Extension with Bezel

J22

Low Rise Momentary

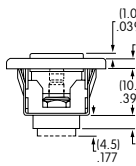

J32

Low Rise Alternate

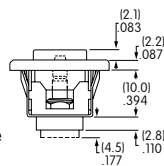

J42

High Rise Momentary

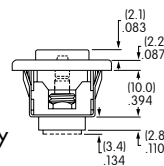

J52

High Rise Alternate

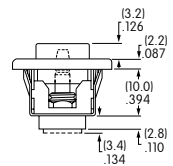

AT208 Bezel with 1 Round LED (AT070 LED)

A

Black

Material: Polycarbonate
Finish: Glossy

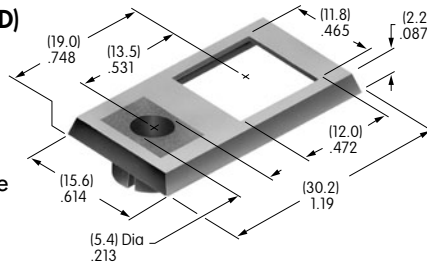

Maximum Panel Thickness
.039" ~ .126"
(1.0mm ~ 3.2mm)
Cutout applies to SP & DP

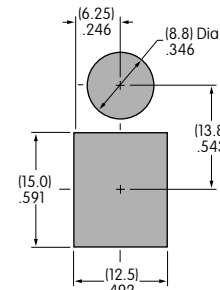

LED colors and specifications on next to last page of this EB section.

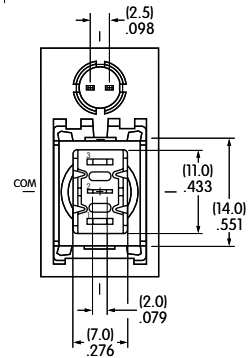
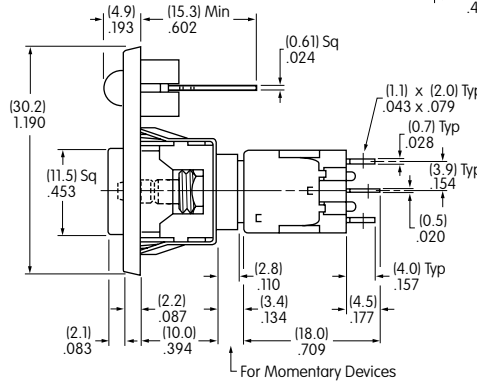
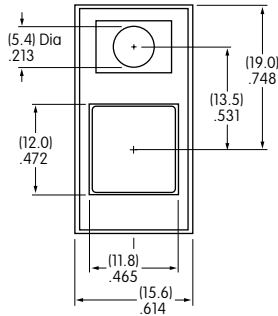

EB2011-B-J42AC

High Rise

Single Pole

Cap Extension with Bezel

J23

Low Rise Momentary

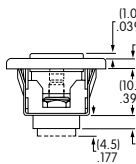

J33

Low Rise Alternate

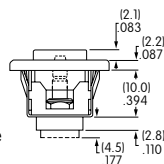

J43

High Rise Momentary

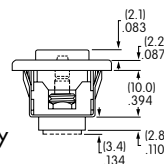

J53

High Rise Alternate

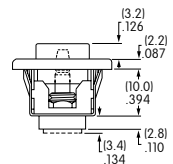

AT212 Bezel with 2 Round LEDs (AT617 LEDs)

A

Black

Material: Polycarbonate
Finish: Glossy

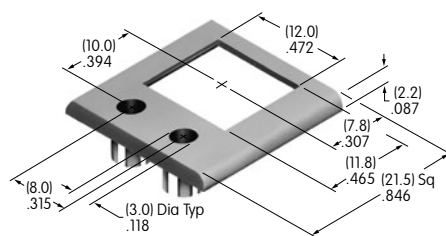

Maximum Panel Thickness
.039" ~ .126" (1.0mm ~ 3.2mm)
Cutout applies to SP & DP

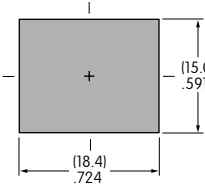

LED colors and specifications on next to last page of this EB section.

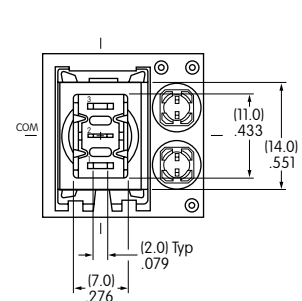
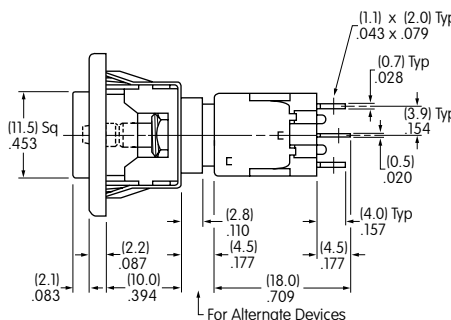
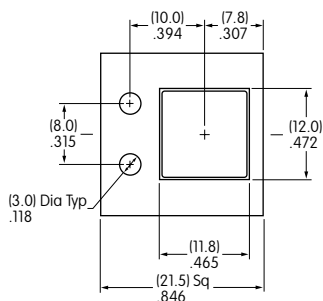

EB2065-B-J33ACF

Low Rise

Single Pole

CAP EXTENSIONS & BEZEL TYPES

Cap Extension with Bezel

J24

Low Rise Momentary

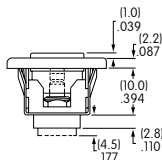

J34

Low Rise Alternate

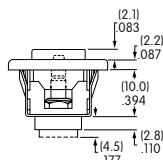

J44

High Rise Momentary

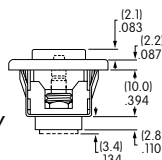

J54

High Rise Alternate

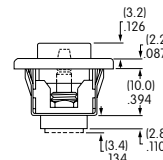

AT213 Bezel with 2 Rectangular LEDs (AT618 LEDs)

A

Black

Material: Polycarbonate
Finish: Glossy

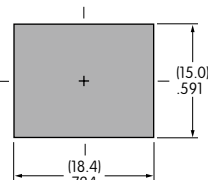
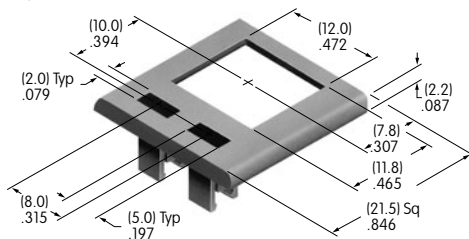

Maximum Panel Thickness
.039" ~ .126" (1.0mm ~ 3.2mm)
Cutout applies to SP & DP

LED colors and specifications on next page of this EB section.

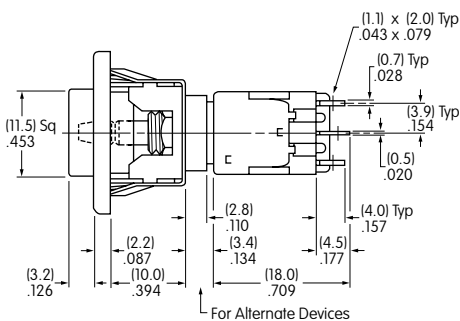
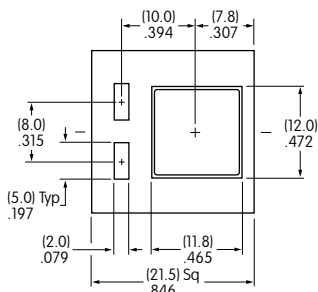

High Rise

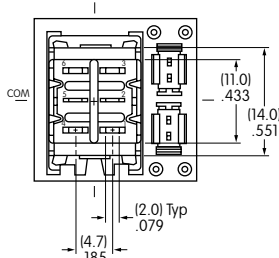

Double Pole



EB2085-B-J54ACF

Toggle
Rockers
Pushbuttons
Illuminated PB
Programmable
Keylocks
Rotaries
Slides
Tactiles
Tilt
Touch
Indicators
Accessories
Supplement

LED COLORS & SPECIFICATIONS

Bezel Orientation on Switch

AT070 LED
For Bezel AT208
with 1 LED

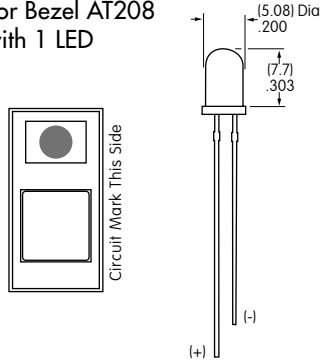

AT617 LED
For Bezel AT212
with 2 Round LEDs

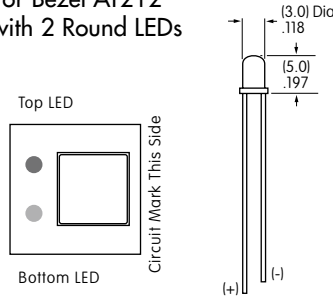

AT618 LED
For Bezel AT213
with 2 Rectangular LEDs

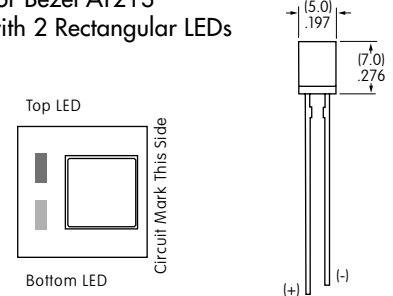

Note: Lead lengths may differ from manufacturing lot to lot. The longer lead is the anode (+).

		AT070		AT617			AT618		
		C	F	C	E	F	C	E	F
	Color	Red	Green	Red	Yellow	Green	Red	Yellow	Green
Forward Peak Current	I_{FM}	25mA	30mA	30mA	30mA	25mA	10mA	30mA	30mA
Typical Forward Current	I_F	20mA	20mA	20mA	20mA	20mA	8mA	24mA	24mA
Forward Voltage	V_F	2.8V	2.1V	2.0V	2.1V	2.2V	1.9V	2.0V	2.1V
Reverse Peak Voltage	V_{RM}	4V	5V	5V	5V	5V	5V	5V	5V
Current Reduction Rate Above 25°C	ΔI_F	0.33 mA/°C	0.40 mA/°C	0.40 mA/°C	0.40 mA/°C	0.33 mA/°C	0.13 mA/°C	0.40 mA/°C	0.40 mA/°C
Ambient Temperature Range (when used with a bezel)		-10° ~ +70°C		-15° ~ +70°C			-15° ~ +70°C		

The electrical specifications shown are determined at a basic temperature of 25°C.
LED circuit is independent of switch operation. LED is colored in OFF state.

If the source voltage is greater than the rated voltage of the LED, a ballast resistor must be connected in series with the lamp.
The ballast resistor calculation and more lamp detail are shown in the Supplement section.

LEGENDS

NKK Switches can provide custom legends for caps. Contact factory for more information.

Suggested Printable Area for Cap

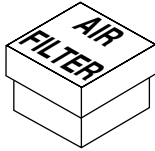
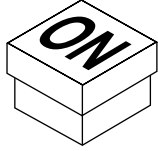

Recommended Print Method:

Screen Print or Pad Print

Epoxy based ink is recommended.

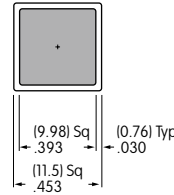

AT465

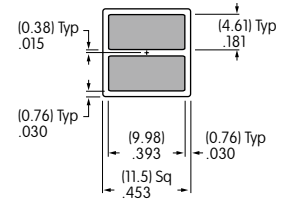

AT465

Shaded areas are printable areas.

Toggles

Rockers

C Pushbuttons

Illuminated PB

Programmable

Keylocks

Rotaries

Slides

Tactiles

Tilt

Touch

Indicators

Accessories

Supplement

General Specifications

FB Series

SB Series

Electrical Capacity (Resistive Load)

Power Level: 500mA @ 125V AC for silver
Logic Level: 0.4VA max. @ 28V AC/DC max. for gold
 (Applicable Range 0.1mA ~ 0.1A @ 20mV ~ 28V)
 Note: Find additional explanation in Supplement section.

3A @ 125V AC or 2A @ 250V AC or
 2A @ 30V DC for silver
 0.4VA max. @ 28V AC/DC max. for gold
 (Applicable Range 0.1mA ~ 0.1A @ 20mV ~ 28V)
 Note: Find explanation of operating range in Supplement section.

Other Ratings

Contact Resistance: 30 milliohms maximum for silver;
 30 milliohms maximum for gold

Insulation Resistance: 100 megohms minimum @ 500V DC

Dielectric Strength: 1,000V AC minimum between contacts &
 between contacts & case for 1 minute minimum

Mechanical Life: 50,000 operations minimum

Electrical Life: 50,000 operations minimum

Nominal Operating Force: 2.16N

Travel: Pretravel .043" (1.1mm)
 Overtravel .022" (0.57mm)
 Total Travel .065" (1.67mm)

10 milliohms maximum for silver;
 20 milliohms maximum for gold
 200 megohms minimum @ 500V DC
 1,000V AC minimum between contacts
 & between contacts & case for 1 minute minimum

30,000 operations minimum
 10,000 operations minimum

4.90N

Normally Open
 Total Travel .088" (2.24mm)
 Normally Closed
 Total Travel .088" (2.24mm)

Materials & Finishes

Plunger: Polyacetal
Bushing: Brass with nickel plating
Case: Phenolic resin
Movable Contactor: Copper with silver or gold plating
Stationary Contacts: Phosphor bronze with silver or gold plating
Terminals: Phosphor bronze with silver or gold plating

Phenolic resin
 Brass with nickel plating
 Phenolic resin
 Copper with silver or gold plating
 Copper with silver or gold plating
 Copper with silver or gold plating

Environmental & Installation Data

Operating Temp Range: -10°C through +70°C (+14°F through +158°F)
Soldering Time & Temperature: Manual Soldering:
 See Profile A in Supplement section.

-10°C through +70°C (+14°F through +158°F)
 Manual Soldering:
 See Profile A in Supplement section.

Standards & Certifications

UL: File No. E44145 - Recognized only when ordered with marking on switch.
 Add "/U" or "/CUL" before dash in part number to order UL recognized switch.
 Models rated 0.5A @ 125V AC Single pole;
 Momentary action circuit with solder lug terminations.

File No. E44145 - Recognized only when ordered with marking on switch.
 Add "/U" or "/CUL" before dash in part number to order UL recognized switch.
 Models rated 3A @ 125V AC & 2A @ 250V AC.
 Single pole: Momentary action circuit with solder lug terminations.

CSA:

File No. 023535_0_000 - Certified only when ordered with marking on switch.
 Add "/C" before dash in part number to order CSA certified switch.
 SB series rated 3A @ 125V AC & 2A @ 250V AC.
 Single pole: Momentary action circuit with solder lug terminations.

Toggles
 Rockers
 Pushbuttons
 Illuminated PB
 Programmable
 Keylocks
 Rotaries
 Slides
 Tactiles
 Tilt
 Touch
 Indicators
 Accessories
 Supplement

Distinctive Characteristics

Optional caps in different colors to vary appearance as needed.

Low operating force for ease of actuation.

Rear panel bushing mount with compact behind panel dimension.

Internal antijamming feature to protect the contacts from damage due to excessive force on the plunger.

Self-cleaning contacts make FB models highly reliable.

Low cost device of rugged one-piece bushing and housing construction.

Reliability of construction with an internal guide to maintain contact alignment.

Epoxy sealed terminals.

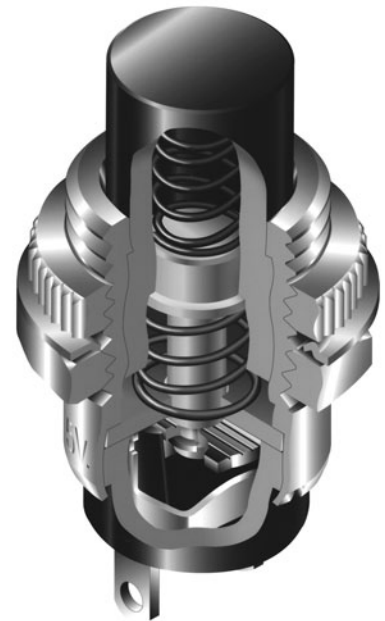
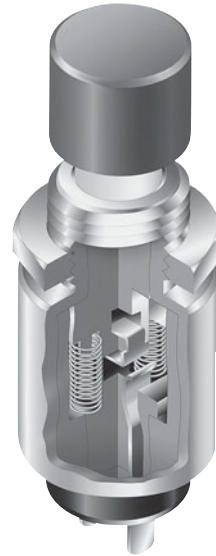

Actual Size FB

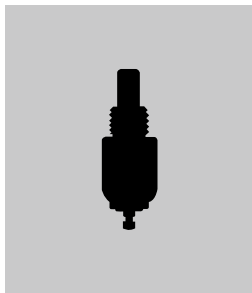

Actual Size SB

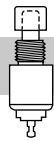
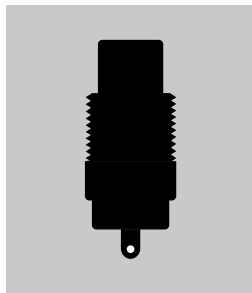

FB Bushing Mount

Page C40



SB Bushing Mount

Page C42

- Toggles
- Rockers
- Pushbuttons**
- Illuminated PB
- Programmable
- Keylocks
- Rotaries
- Slides
- Tactiles
- Tilt
- Touch
- Indicators
- Accessories
- Supplement

TYPICAL SWITCH ORDERING EXAMPLE

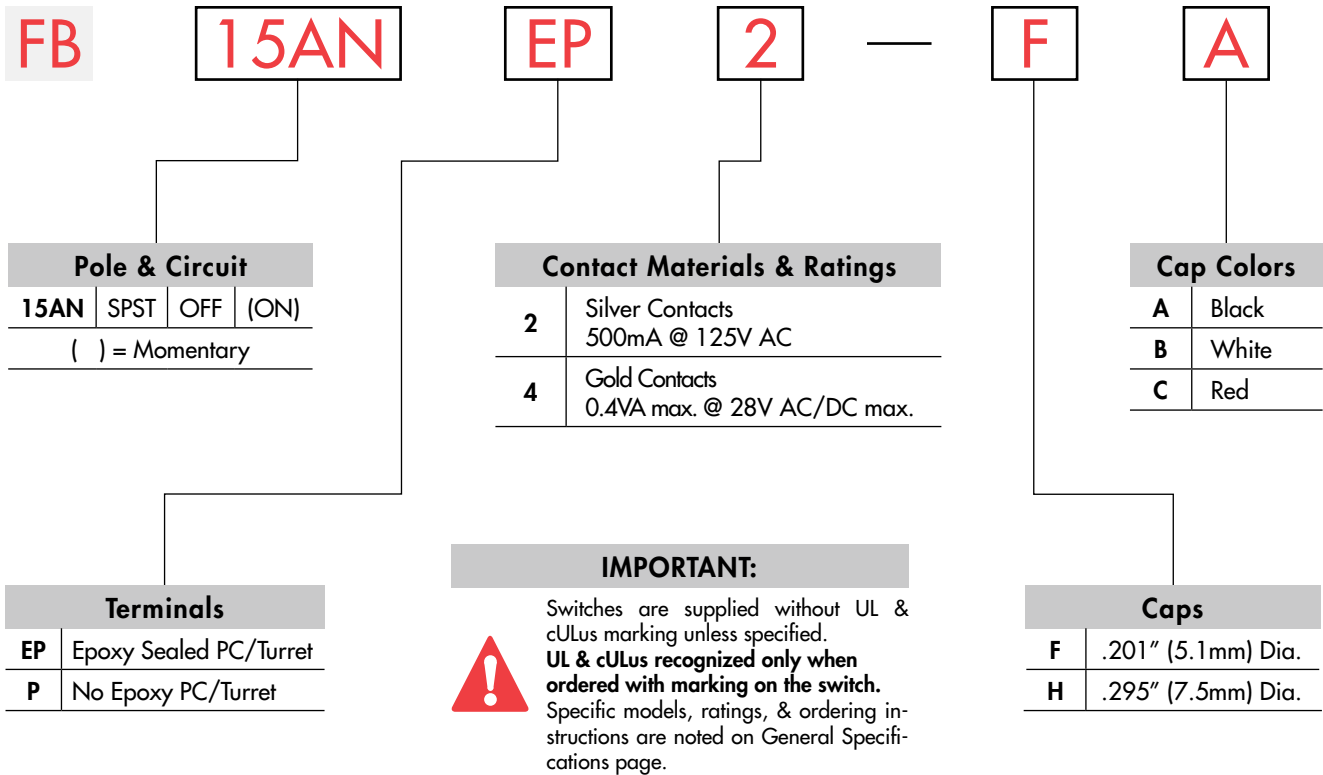

DESCRIPTION FOR TYPICAL ORDERING EXAMPLE

FB15ANEP2-FA

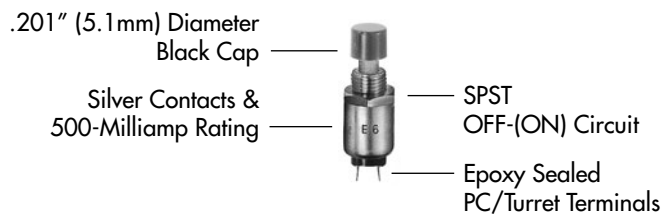

POLE & CIRCUIT

		Plunger Position () = Momentary		Connected Terminals		Throw & Switch Schematics
Pole	Model	Normal	Down	Normal	Down	
SP	FB15AN	OFF	(ON)	OPEN	1-2	SPST
						Note: Terminal numbers are not actually on the switch.

TERMINALS

EP Epoxy Sealed
PC/Turret Terminals

P No Epoxy
PC/Turret Terminals

CONTACT MATERIALS & RATINGS

2 Silver Contacts

Power Level

500mA @ 125V AC

4 Gold Contacts

Logic Level

0.4VA maximum @ 28V AC/DC maximum

Complete explanation of operating range in Supplement section.

TYPICAL SWITCH DIMENSIONS

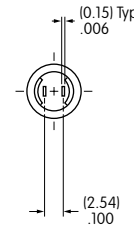
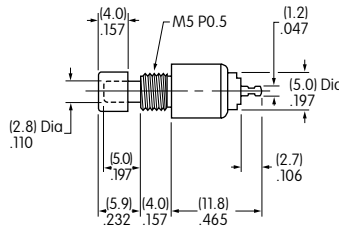
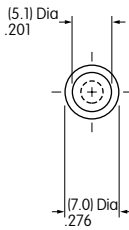

PC/Turret



Plunger is white polyacetal.

FB15ANEP2-FA

SLIP-ON CAPS & COLORS

F AT475
.201" (5.1mm) Diameter

Material: Polyamide

Finish: Glossy

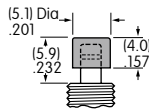

H AT496
.295" (7.5mm) Diameter

Material: Polyamide

Finish: Glossy

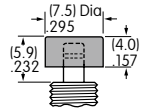

Colors Available:

A Black

B White

C Red

STANDARD HARDWARE & PANEL CUTOUT

AT536 Hex Nut

Material:
Brass with nickel plating

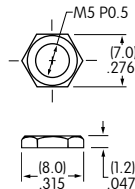

Panel Thickness:

.110" (2.8mm) maximum

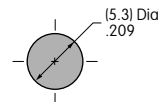

TYPICAL SWITCH ORDERING EXAMPLE

SB40 **11NO** **M** **C** **G** **2A**

Pole & Circuits			
Normally Open			
11NO	SPST	OFF	(ON)
Normally Closed			
11NC	SPST	ON	(OFF)
() = Momentary			

Plunger Colors	
No Code	Black
C	Red

Contact Materials & Ratings	
No Code	Silver Contacts 3A @ 125V AC or 2A @ 250V DC
G	Gold Contacts 0.4VA max. @ 28V AC/DC max.

Bushings	
M	Metric Threaded M12 P1
H	Inch Threaded 15/32-32 NS

Slip-On Cap & Colors	
No Code	Without Cap
2A	Black
2B	White
2C	Red
2E	Yellow
2F	Green
2G	Blue

IMPORTANT:



Switches are supplied without UL, cULus & CSA marking unless specified. **UL, cULus & CSA recognized only when ordered with marking on the switch.** Specific models, ratings, & ordering instructions are noted on General Specifications page.

DESCRIPTION FOR TYPICAL ORDERING EXAMPLE

SB4011NOM

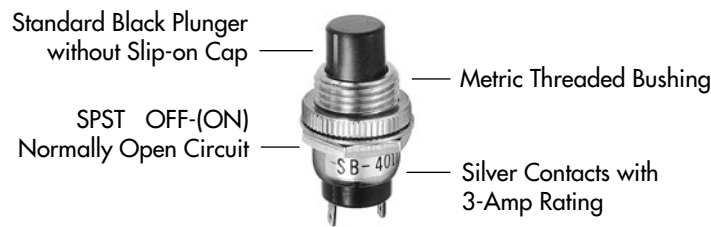

POLE & CIRCUITS

		Plunger Position () = Momentary		Connected Terminals		Throw & Switch Schematics
Pole	Model	Normal	Down	Normal	Down	
SP	SB4011NO	OFF	(ON)	OPEN	1-2	Note: Terminal numbers are not actually on the switch. SPST NO NC
	SB4011NC	ON	(OFF)	1-2	OPEN	

TYPICAL SWITCH DIMENSIONS

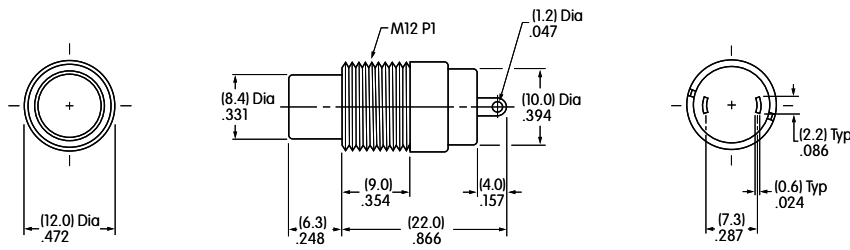

SB4011NOM

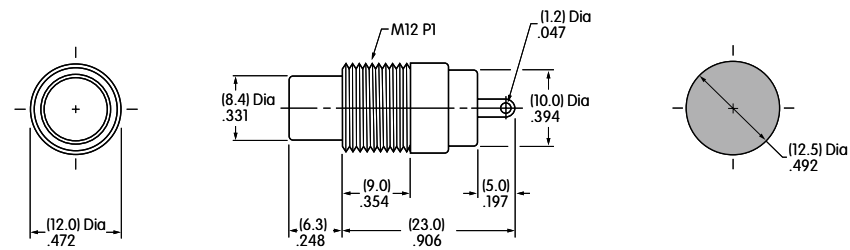

SB4011NCM

Metric Bushing



SB4011NOM

Hardware provided:
 1 AT504 Knurled Face Nut
 1 AT508 Lockwasher
 1 AT527M Hex Mounting Nut

Panel Thickness:
 .157" (4.0mm)

Details in Hardware &
 Accessories section.

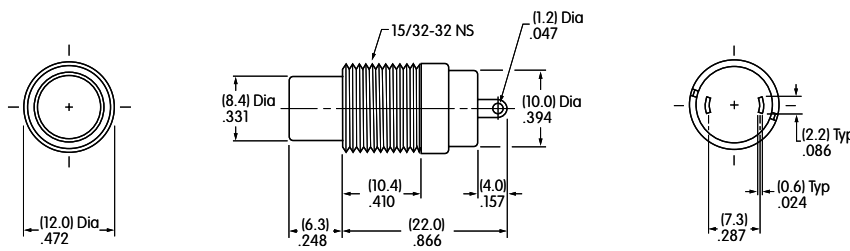

SB4011NOH

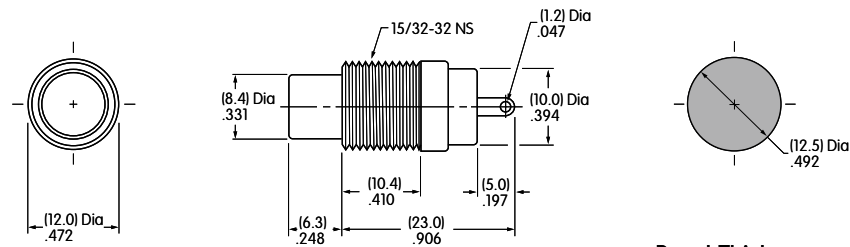

SB4011NCH

Inch Bushing



SB4011NCH

Hardware provided:
 2 AT503H Hex Mounting Nuts
 1 AT508 Lockwasher

Panel Thickness:
 .157" (4.0mm)

Details in Hardware &
 Accessories section.

SLIP-ON CAP & COLORS

AT422
 .394" (10.0mm) Diameter Cap

Material: Polyethylene
 Finish: Matte

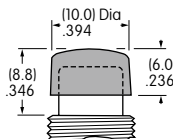

2A	Black	2C	Red	2F	Green
2B	White	2E	Yellow	2G	Blue

Toggle
 Rockers
Pushbuttons
 Illuminated PB
 Programmable
 Keylocks
 Rotaries
 Slides
 Tactiles
 Tilt
 Touch
 Indicators
 Accessories
 Supplement

General Specifications

Electrical Capacity (Resistive Load)

Logic Level: 0.4VA maximum @ 28V AC/DC maximum
(Applicable Range 0.1mA ~ 0.1A @ 20mV ~ 28V)
Note: Find additional explanation of operating range in Supplement section.

Other Ratings

Contact Resistance: 80 milliohms maximum
Insulation Resistance: 500 megohms minimum @ 500V DC
Dielectric Strength: 500V AC minimum for 1 minute minimum
Mechanical Life: 50,000 operations minimum
Electrical Life: 50,000 operations minimum
Nominal Operating Force: 1.70N
Travel: Pretravel .035" (0.9mm); Overtravel .008" (0.2mm); Total Travel .043" (1.1mm)

Materials & Finishes

Actuator: Polyacetal
Case: Glass fiber reinforced polyamide
Sealing Rings: Nitrile butadiene rubber
Movable Contacts: Phosphor bronze with gold plating
Stationary Contacts: Phosphor bronze with gold plating
Base: Glass fiber reinforced polyamide
Mounting Bracket: Phosphor bronze with tin plating
Terminals: Phosphor bronze with gold plating

Environmental Data

Operating Temp Range: -30°C through +85°C (-22°F through +185°F)
Humidity: 90 ~ 95% humidity for 96 hours @ 40°C (104°F)
Vibration: 10 ~ 55Hz with peak-to-peak amplitude of 1.5mm traversing the frequency range & returning in 1 minute; 3 right angled directions for 2 hours
Shock: 50G (490m/s²) acceleration (tested in 6 right angled directions, with 5 shocks in each direction)

Installation

Cap Installation Force: 39.1N (8.8 lbf) maximum downward force on actuator

PCB Processing

Soldering: Wave Soldering Recommended: See Profile A in Supplement section.
Manual Soldering: See Profile A in Supplement section.
Cleaning: Automated cleaning. See Cleaning specifications in Supplement section.

Standards & Certifications

The GB Series pushbuttons have not been tested for UL recognition or CSA certification. These switches are designed for use in a low-voltage, low-current, logic-level circuit. When used as intended in a logic-level circuit, the results do not produce hazardous energy.

Distinctive Characteristics

Ultra-miniature size allows high density mounting, and extremely light weight of 0.25 gram makes these switches ideal for handheld equipment.

Totally sealed body construction prevents contact contamination and allows time- and money-saving automated soldering and cleaning.

Award-winning STC contact mechanism with benefits unavailable in conventional mechanisms: smoother, positive detent actuation, increased contact stability and unparalleled logic-level reliability. (Additional STC details in Terms & Acronyms; see Supplement section.)

.100" x .100" (2.54mm x 2.54mm) terminal spacing conforms to standard PC board grid-spacing. Round terminals facilitate easier through-hole mounting on PC boards.

Matching indicators available.

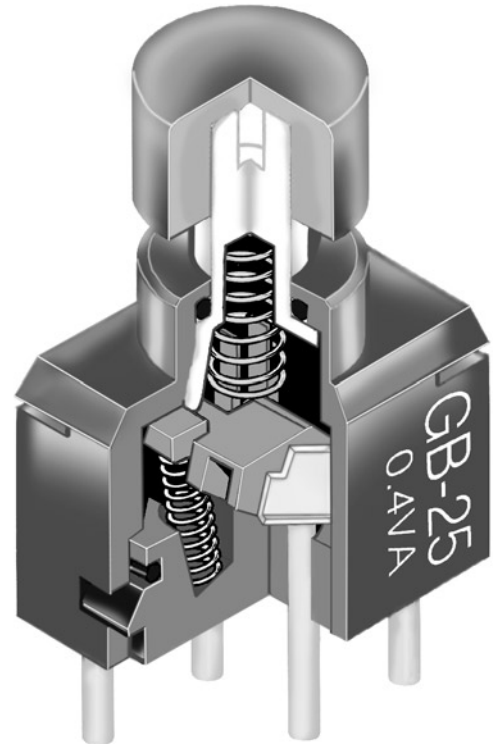

Actual Size

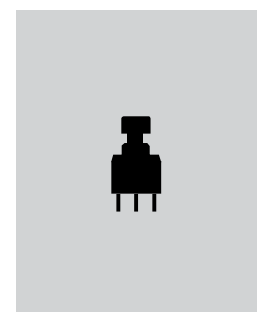

- Supplement
- Accessories
- Indicators
- Touch
- Tilt
- Tactiles
- Slides
- Rotaries
- Keylocks
- Programmable
- Illuminated PB
- Pushbuttons
- Rockers
- Toggles

TYPICAL SWITCH ORDERING EXAMPLE

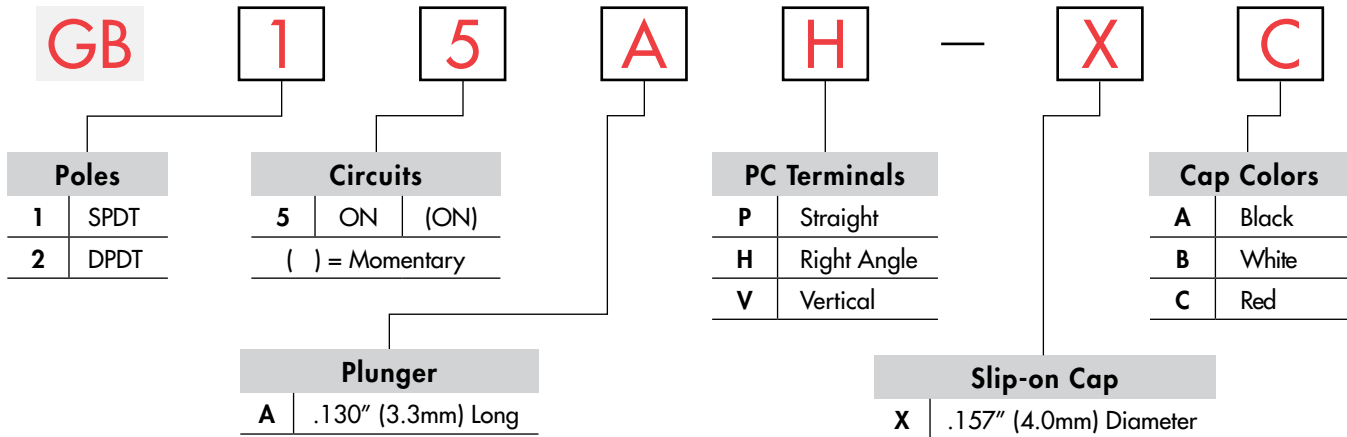

DESCRIPTION FOR TYPICAL ORDERING EXAMPLE

GB15AH-XC

.130" (3.3mm) Long Plunger with
.157" (4.0mm) Diameter Red Cap



SPDT
ON-(ON) Circuit
Right Angle PC Terminals

POLES & CIRCUITS

Pole	Model	Plunger Position () = Momentary		Connected Terminals		Throw & Schematics
		Normal 	Down 	Normal 	Down 	
SP	GB15	ON	(ON)	5-6	5-4	SPDT
DP	GB25	ON	(ON)	5-6 2-3	5-4 2-1	DPDT

Note: Terminal numbers are not actually on the switch.

PLUNGER

A .130" (3.3mm) Long Plunger

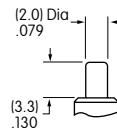

PC TERMINALS

P Straight

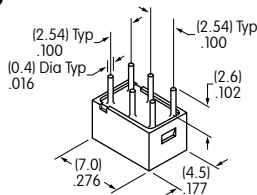

H Right Angle

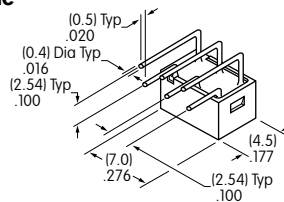

V Vertical

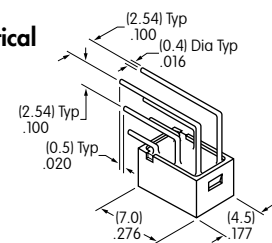

SLIP-ON CAP & COLORS

X **AT4063**
.157" (4.0mm) Diameter Slip-on Cap

Material: Polyamide

Finish: Glossy



Actual Size

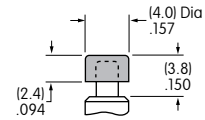

Cap Colors Available:



Black



White



Red

TYPICAL SWITCH DIMENSIONS

Single & Double Pole

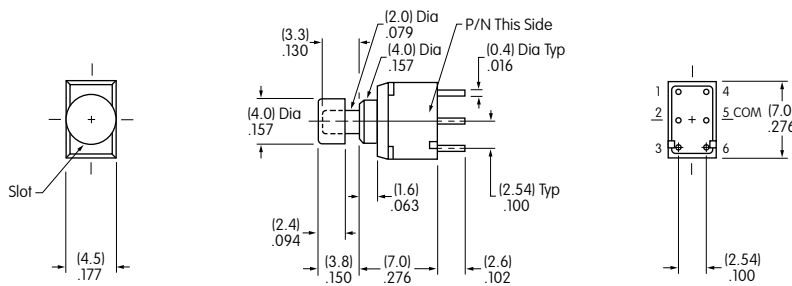

On single pole switches terminals 1 & 3 are support pins.

Straight PC

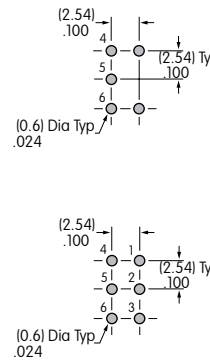

GB25AP-XC

Single & Double Pole

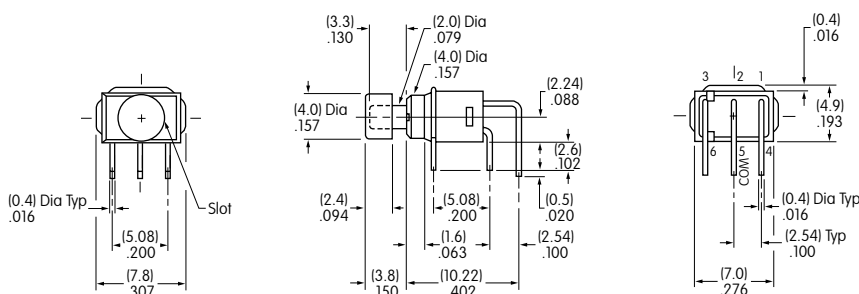

Right Angle PC

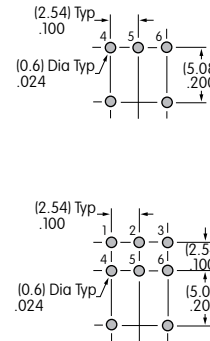

GB25AH-XC

Single & Double Pole

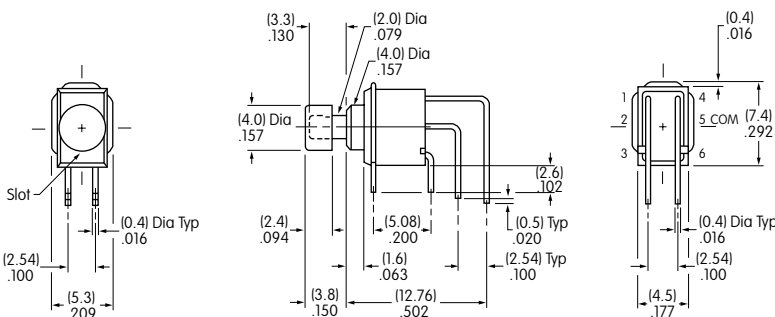

Vertical PC

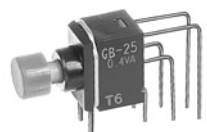
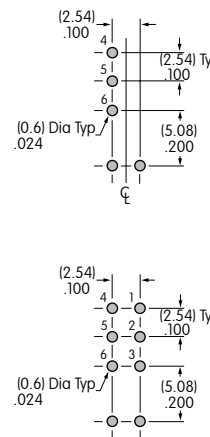

GB25AV-XC

General Specifications

Electrical Capacity (Resistive Load)

Logic Level: 0.4VA maximum @ 28V AC/DC maximum
(Applicable Range 0.1mA ~ 0.1A @ 20mV ~ 28V)
Note: Find additional explanation of operating range in Supplement section.

Other Ratings

Contact Resistance: 80 milliohms maximum
Insulation Resistance: 500 megohms minimum @ 500V DC
Dielectric Strength: 500V AC minimum for 1 minute minimum
Mechanical Life: 50,000 operations minimum
Electrical Life: 50,000 operations minimum
Nominal Operating Force: 1.0N
Travel: Pretravel .020" (0.5mm); Overtravel .023 (0.6mm); Total Travel .043" (1.1mm)

Materials & Finishes

Actuator: Glass fiber reinforced polyamide (UL94V-0)
Case: Glass fiber reinforced polyamide (UL94V-0)
Movable Contacts: Phosphor bronze with gold plating
Stationary Contacts: Brass with gold plating
Base: Glass fiber reinforced polyamide (UL94V-0)
Mounting Bracket: Phosphor bronze with tin plating
Terminals: Brass with gold plating

Environmental Data

Operating Temperature Range: -25°C through +70°C (-13°F through +158°F)
Humidity: 90 ~ 95% humidity for 240 hours @ 40°C (104°F)
Vibration: 10 ~ 55Hz with peak-to-peak amplitude of 1.5mm traversing the frequency range & returning in 1 minute; 3 right angled directions for 2 hours
Shock: 50G (490m/s²) acceleration (tested in 6 right angled directions, with 5 shocks in each direction)

PCB Processing

Soldering: Wave Soldering Recommended: See Profile A in Supplement section.
Manual Soldering: See Profile A in Supplement section.
Cleaning: These devices are not process sealed. Hand clean locally using alcohol based solution.

Standards & Certifications

Flammability Standards: UL94V-0 actuator, case, & base
 The GB2 Series pushbuttons have not been tested for UL recognition or CSA certification. These switches are designed for use in a low-voltage, low-current, logic-level circuit. When used as intended in a logic-level circuit, the results do not produce hazardous energy.

Distinctive Characteristics

Unique, off-center actuator allows high density setup and easy actuation while avoiding accidental operation in compact environments.

Side-by-side, block mounting can be achieved by use of bracket AT546 on straight PC mounting types.

Off-Momentary On Circuit.

Black, white, and red snap-on caps available.

Extremely thin size allows high density PCB mounting and makes these switches ideal for handheld equipment.

Award-winning STC contact mechanism with benefits unavailable in conventional mechanisms: smoother, positive detent actuation, increased contact stability and unparalleled logic-level reliability. (Additional STC details in Terms & Acronyms; see Supplement section.)

Molded-in, epoxy sealed terminals lock out flux and other contaminants.

.100" x .100" (2.54mm x 2.54mm) terminal spacing conforms to standard PC board grid spacing for straight and angle mounting.

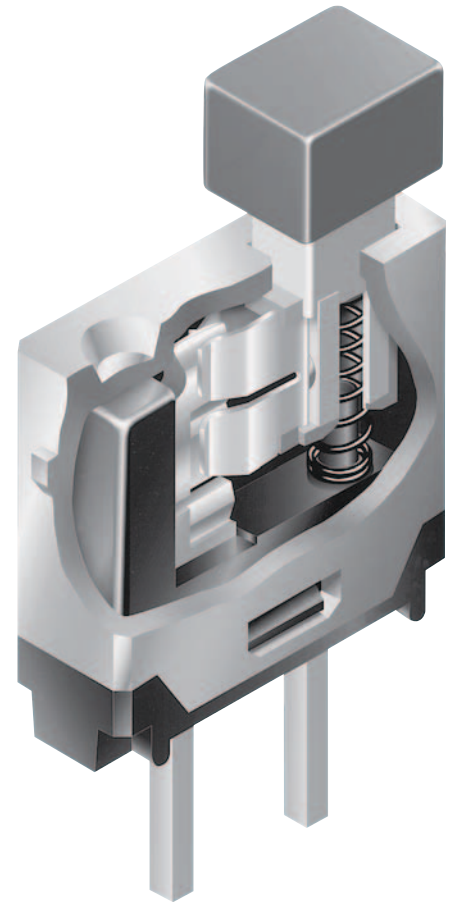

Actual Size

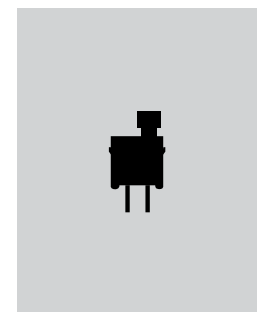

TYPICAL SWITCH ORDERING EXAMPLE

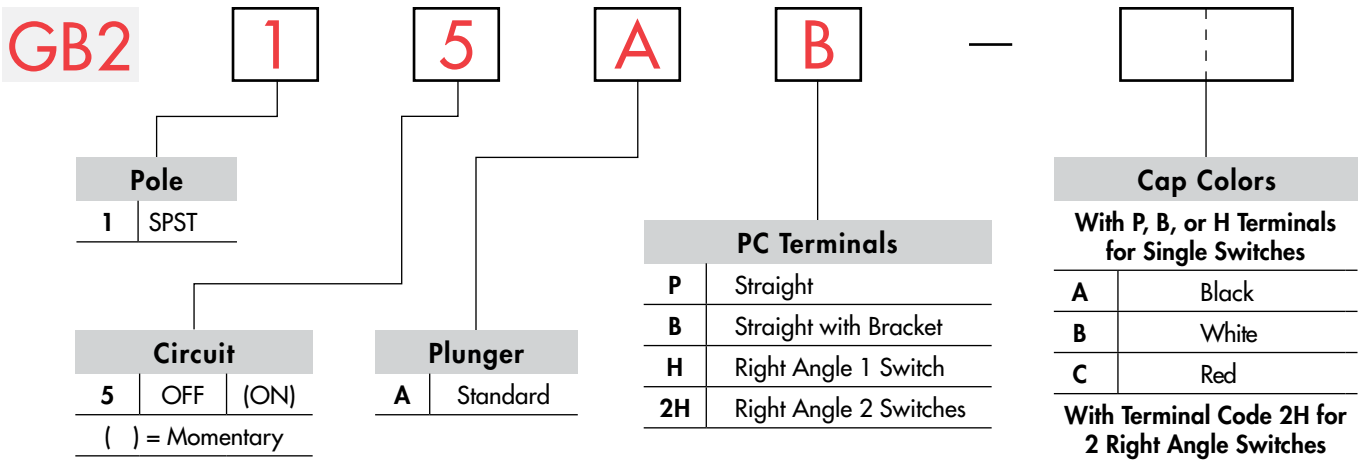

DESCRIPTION FOR TYPICAL ORDERING EXAMPLE

GB215AB

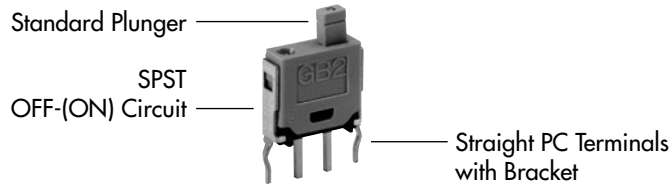

POLE & CIRCUIT

Pole	Model	Plunger Position () = Momentary		Connected Terminals		Throw & Schematics
		Normal	Down	Normal	Down	
SP	GB215	OFF	(ON)	OPEN	1-2 1-2 3-4	<p>Note: Terminal numbers are not actually on the switch.</p>

TYPICAL SWITCH DIMENSIONS

Straight PC



GB215AP

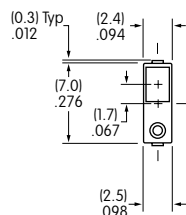

Single Pole

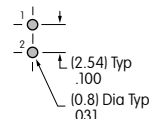
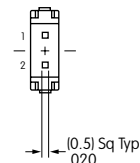
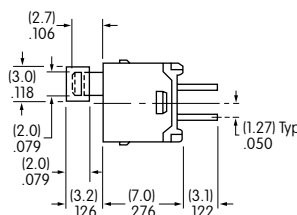

TYPICAL SWITCH DIMENSIONS

Single Pole

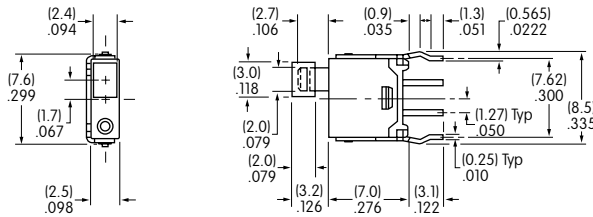

Straight PC with Bracket

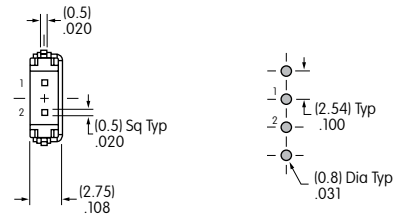

GB215AB

Single Pole with 1 Switch

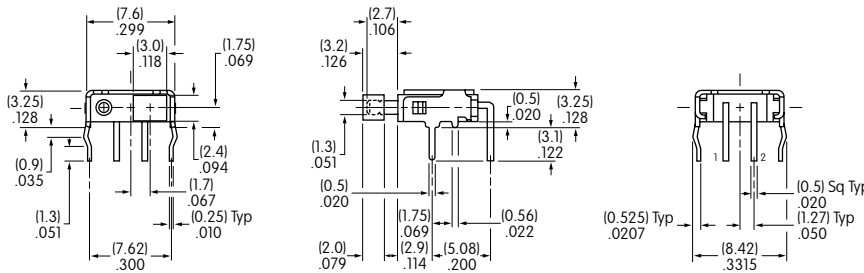

Right Angle PC

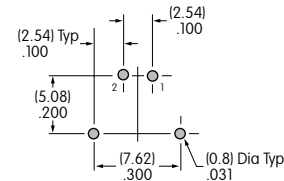

GB215AH

Single Pole with 2 Switches

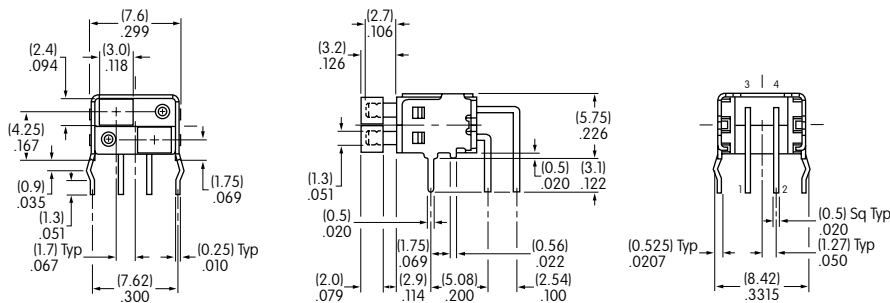

Right Angle PC

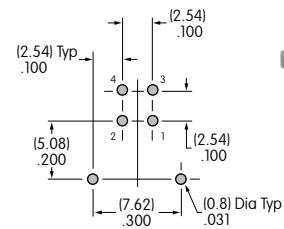

GB215A2H

SNAP-ON CAP & MOUNTING BRACKET

A AT4137 Rectangular Snap-on Cap
Black

B AT4137 Rectangular Snap-on Cap
White

C AT4137 Rectangular Snap-on Cap
Red

Material: PBT
Finish: Glossy



Actual Size

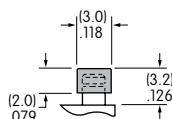

AT546
Mounting Bracket
for Block Mounting

Material:
Phosphor Bronze
with Tin Plating

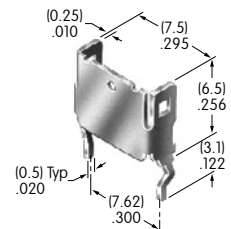

General Specifications

Electrical Capacity (Resistive Load)

Logic Level: 0.4VA maximum @ 28V AC/DC maximum
(Applicable Range 0.1mA ~ 0.1A @ 20mV ~ 28V)
Note: Find additional explanation of operating range in Supplement section.

Other Ratings

Contact Resistance: 80 milliohms maximum
Insulation Resistance: 500 megohms minimum @ 500V DC
Dielectric Strength: 500V AC minimum for 1 minute minimum
Mechanical Life: 50,000 operations minimum
Electrical Life: 50,000 operations minimum
Nominal Operating Force: 2.0N
Travel: Pretravel: .024" (0.6mm); Overtravel: .019" (0.5mm); Total Travel: .043" (1.1mm)

Materials & Finishes

Actuator: Polyphenylene sulfide (UL94V-0)
Case: Polyphenylene sulfide (UL94V-0)
Sealing Rings: Nitrile butadiene rubber
Movable Contacts: Phosphor bronze with gold plating
Stationary Contacts: Phosphor bronze with gold plating
Base: Polyphenylene sulfide (UL94V-0)
Terminals: Phosphor bronze with gold plating

Environmental Data

Operating Temperature Range: -30°C through +85°C (-22°F through +185°F)
Humidity: 90 ~ 95% humidity for 96 hours @ 40°C (104°F)
Vibration: 10 ~ 500Hz with peak-to-peak amplitude of 1.5mm traversing the frequency range & returning in 1 minute; 3 right angled directions for 2 hours
Shock: 50G (490m/s²) acceleration (tested in 6 right angled directions, with 5 shocks in each direction)

Installation

Mounting: It is recommended that the body of models for upright mounting without bracket be fastened to a panel or similar support for protection of solder joints from mechanical stress.
Coplanarity: See specifications in Terms & Acronyms in Supplement section.

Processing

Soldering: Reflow Soldering Recommended. See Profile B in Supplement section.
Manual Soldering: See Profile B in Supplement section.
Cleaning: Automated cleaning. See Cleaning specifications in Supplement section.

Standards & Certifications

Flammability Standard: UL94V-0 actuator, case & base
The G3B Series pushbuttons have not been tested for UL recognition or CSA certification. These switches are designed for use in a low-voltage, low-current, logic-level circuit. When used as intended in a logic-level circuit, the results do not produce hazardous energy.

Distinctive Characteristics

Ultra-miniature size allows high density mounting, and extremely light weight of 0.6 gram makes these switches ideal for handheld equipment.

Tape-reel and stick-tube packaging allow rapid automated placement of surface mount devices. Tape-reel packaging meets EIA-481-D Standard.

Heat resistant resin used for housing, base, and plunger allows vapor phase and infrared convection reflow soldering.

Combination of design features achieves total seal and allows automated processing techniques, including flux cleaning procedures: one-piece bushing and housing, rubber seals surrounding actuator and base, epoxy at joint of case and base, and molded-in, epoxy-sealed terminals.

Award-winning STC contact mechanism with benefits unavailable in conventional mechanisms: smoother, positive detent actuation, increased contact stability and unparalleled logic-level reliability. (Additional STC details in Terms & Acronyms; see Supplement section.)

Gull-wing terminals provide mechanical stability during soldering and simplified solder joint inspection.

Coplanarity: all considered surfaces must lie between two parallel planes that area maximum distance apart of .0059" (0.15mm). (Additional coplanarity details in Terms and Acronyms in the Supplement section.)

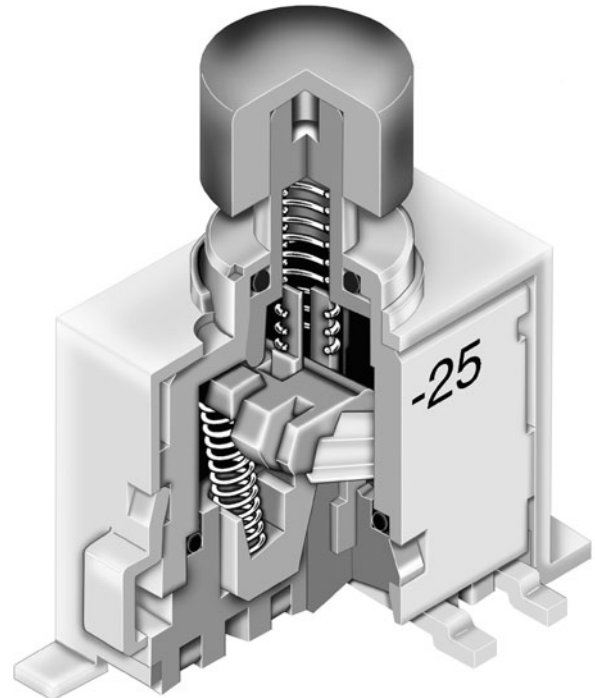

Actual Size



Toggles

Rockers

 Pushbuttons

Illuminated PB

Programmable

Keylocks

Rotaries

Slides

Tactiles

Tilt

Touch

Indicators

Accessories

Supplement

TYPICAL SWITCH ORDERING EXAMPLE

G3B **1** **5** **A** **B** — — —

Poles	
1	SPDT
2	DPDT

Plunger	
A	.130" (3.3mm) Long

Terminals	
P	Gull Wing for Upright Mount
B	Gull Wing for Upright with Bracket
H	Gull Wing for Right Angle

Colors	
A	Black
B	White
C	Red

Circuits		
5	ON	(ON)

() = Momentary

Packaging	
No Code	Partitioned Tray for Upright & Right Angle - Any Quantity
R	Tape-Reel for Right Angle Only 500 Pieces/Reel
S	Stick-Tube for Upright Mount 50 Pieces/Stick

Packaging details at end of G3B Series

Optional Caps	
X	Slip-on Cap .157" (4.0mm) Diameter (For installation after processing only)
Y	Process Compatible Cap .157" (4.0mm) Diameter (Combines with R or S packaging only)

DESCRIPTION FOR TYPICAL ORDERING EXAMPLE

G3B15AB

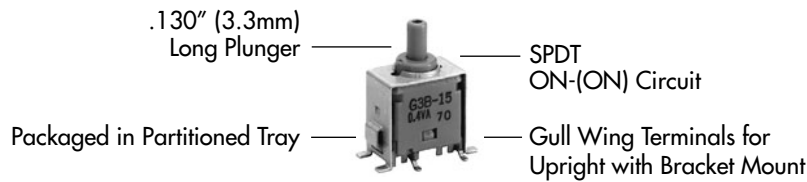

POLES & CIRCUITS

Pole	Model	Plunger Position () = Momentary		Connected Terminals		Throw & Schematics
		Normal	Down	Normal	Down	
SP	G3B15	ON	(ON)	5-6	5-4	SPDT Note: Terminal numbers are not actually on the switch.
DP	G3B25	ON	(ON)	5-6 2-3	5-4 2-1	DPDT

PLUNGER & OPTIONAL CAPS

A .130" (3.3mm)
Long Plunger

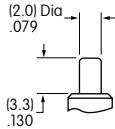

X AT4063 Slip-on Cap
.157" (4.0mm) Diameter

Available with bulk packaging only. Cap must be installed after processing.

Material: Polyamide
Finish: Glossy



Actual Size

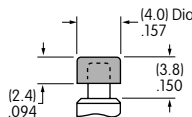

Y Process Compatible Cap
.157" (4.0mm) Diameter

Factory assembled. Available with tape-reel or stick-tube packaging only.

Caution: Pulling force specification for this cap is not warranted after reflow processing.

Material: Polyamide
Finish: Glossy

Cap Colors Available:



Black



White



Red

TYPICAL SWITCH DIMENSIONS

Single & Double Pole

Upright Mounting

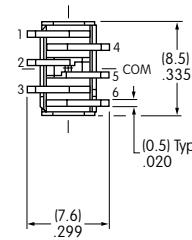
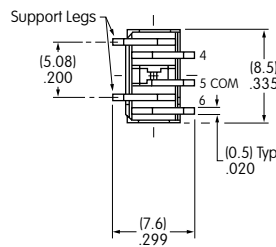
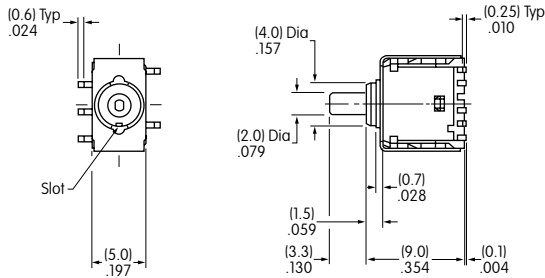

G3B25AP

Single & Double Pole

Upright Mounting with Bracket

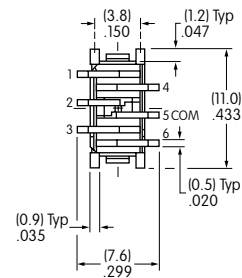
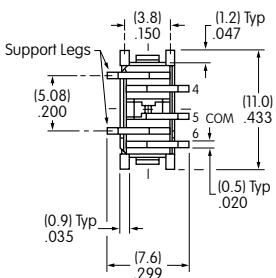
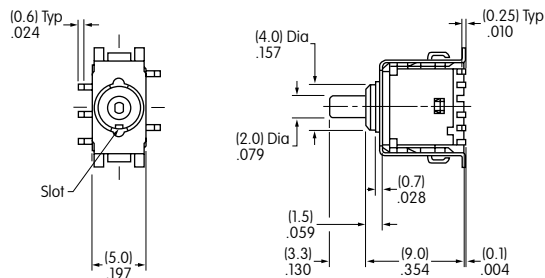

G3B15AB

Right Angle Mounting

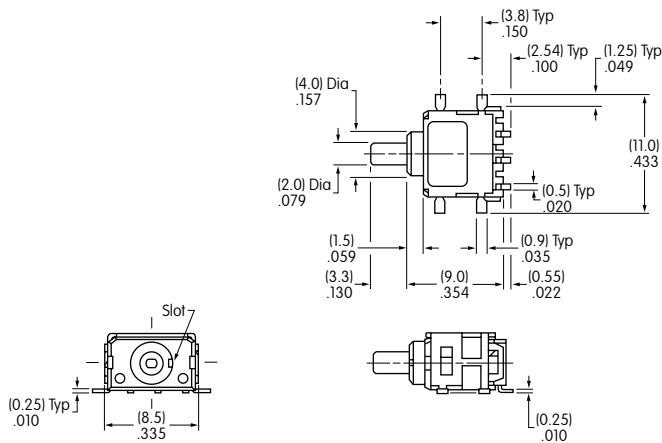

Single Pole

Double Pole

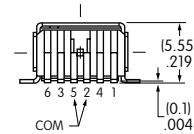
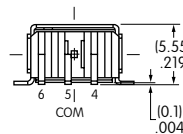

G3B15AH

Toggles

Rockers

Pushbuttons

Illuminated PB

Keylocks

Rotaries

Slides

Tactiles

Tilt

Touch

Indicators

Accessories

Supplement

Pad Layouts for Surface Mount Terminals

Single Pole Double Throw

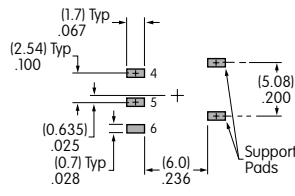

Double Pole Double Throw

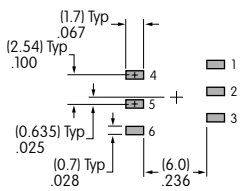

Upright Mounting

Upright Mounting with Bracket

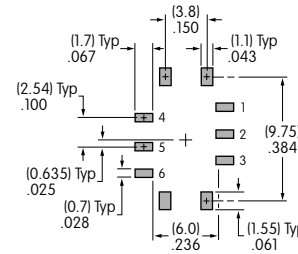
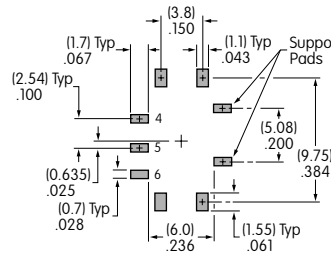

Right Angle Mounting

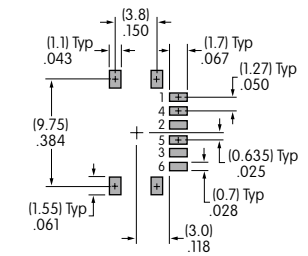
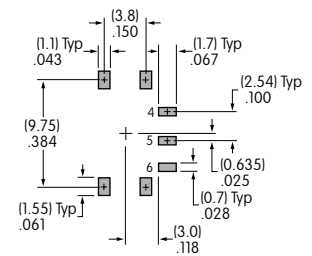

PACKAGING

No Code

Partitioned Tray for Upright & Right Angle

Any quantity

If the G3 upright models are ordered in less than 50-piece increments or the right angle models in less than 500-piece increments, the switches are packaged in a partitioned tray. No code is required.



R

Tape-Reel for Right Angle

500 pieces per reel

Switches must be ordered in 500-piece increments when tape-reel packaging is selected.

This packaging meets EIA-481-D Standard for "16mm and 24mm Embossed Carrier Taping of Surface Mount Components for Automatic Handling."



PACKAGING (CONTINUED)

S Stick-Tube for Upright Mount

50 pieces per stick

Switches must be ordered in 50-piece increments when stick-tube packaging is selected.

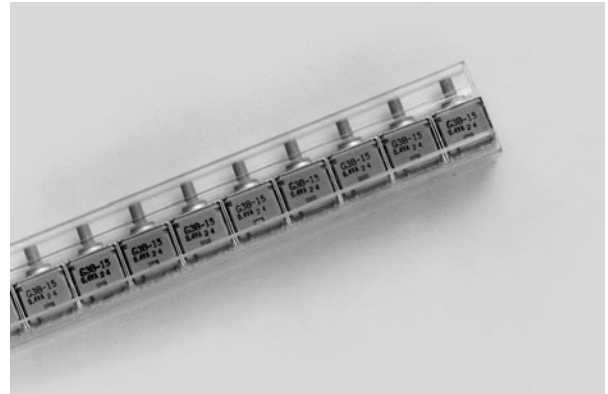

Tape-Reel Packaging for Right Angle Mount

Each tape-reel of 550 pockets contains 500 switches.

Minimum Leader Length: 7.87" (200mm) Minimum Trailer Length: 1.97" (50mm)

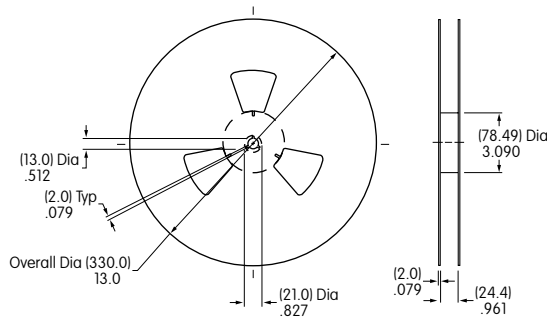

Reel Dimensions

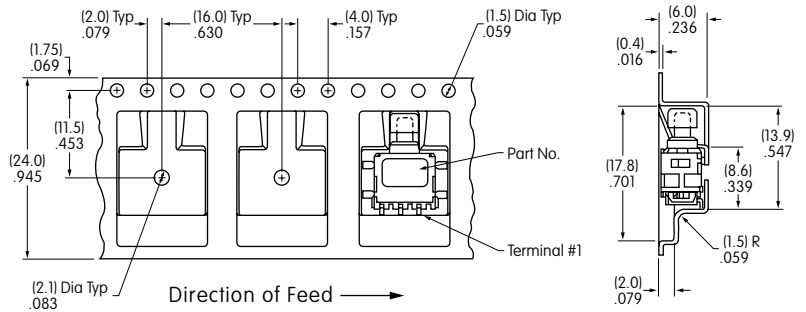

Tape Dimensions

Stick-Tube Packaging for Upright Mount

Each stick-tube contains 50 switches.

L = Length

G3B Upright (code P)
18.31" (465mm)

G3B Upright with Bracket (code B)
21.26" (540mm)

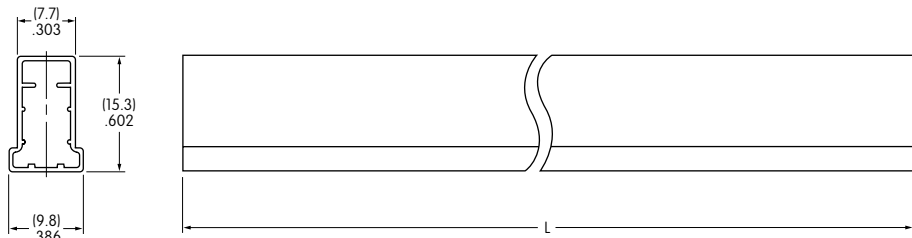

Stick-Tube Dimensions

General Specifications

Electrical Capacity (Resistive Load)

Power Level: 10A @ 125/250V AC for JPM models & 16A @ 125/250V AC for JPL models

Other Ratings

Contact Resistance: 20 milliohms maximum

Insulation Resistance: 1,000 megohms minimum @ 500V DC

Dielectric Strength: 2,000V AC minimum between contacts for 1 minute minimum;
4,000V AC minimum between contacts & case for 1 minute minimum

Mechanical Life: 25,000 operations minimum

Electrical Life: 25,000 operations minimum

Nominal Operating Force: JPM Single Pole 3.53N & Double Pole 6.47N

JPL Single Pole 4.51N & Double Pole 9.02 N

Contact Timing: Nonshorting (break before make)

Latchdown: Normal position - flush with barrier; latchdown position - .079" (2.0mm) below normal

Travel: Pretravel .059" (1.5mm); Overtravel .071" (1.8mm); Total Travel .130" (3.3mm)

Materials & Finishes

Housing/Frame & Barrier: Polyamide (UL94V-0)

Interior Seal: Polyphenylene sulfide (UL94V-0)

Case/Base: Melamine (UL94V-0)

Movable Contacts: Silver alloy

Stationary Contacts: Silver alloy

Terminals: Brass with silver plating

Environmental Data

Operating Temp Range: -10°C through +70°C (+14°F through +158°F)

Humidity: 90 ~ 95% humidity for 96 hours @ 40°C (104°F)

Vibration: 10 ~ 55Hz with peak-to-peak amplitude of 1.5mm traversing the frequency range & returning in 1 minute; 3 right angled directions for 2 hours

Shock: 50G (490m/s²) acceleration (tested in 6 right angled directions, with 5 shocks in each direction)

Process Seal: Dust resistant inner seal

Installation

Soldering Time & Temp: Manual Soldering: See Profile A in Supplement section.

Standards & Certifications

Flammability Standards: UL94V-0 for housing/frame, barrier, interior seal, & case/base

TV Ratings for UL: JPM (TV-5) Overload Test @ 125V AC for 50 operations:

Steady State Current (rms) 7.5A; Minimum Inrush Current (peak) 111A

JPM (TV-5) Endurance Test @ 125V AC for 25,000 operations:

Steady State Current (rms) 5A; Minimum Inrush Current (peak) 78A

JPL (TV-8) Overload Test @ 125V AC for 50 operations:

Steady State Current (rms) 12A; Minimum Inrush Current (peak) 163A

JPL (TV-8) Endurance Test @ 125V AC for 25,000 operations:

Steady State Current (rms) 8A; Minimum Inrush Current (peak) 117A

UL: **File No. E44145 - Recognized only when ordered with marking on switch.**

Add "/U" or "/CUL" before dash in part number to order UL recognized switch.

All JPM models certified at 10A @ 125V AC, TV5 & JPL models at 16A @ 125V AC, TV8.

VDE: **License No. 113494 - Approved only when ordered with marking on switch.**

Add "/V" before dash in part number to order VDE approved switch.

All JPM models approved at steady state 5A, inrush 80A, resistive 10A, & motor load 6A all at 250V AC.

License No. 097579

All JPL models approved at steady state 8A, inrush 128A, resistive 16A, & motor load 8A all at 250V AC.

Distinctive Characteristics

Industry's first molded pushbutton with TV rating. Designed to handle large inrush current. JPM models certified for TV-5 rating and JPL models for TV-8 rating.

Prominent external insulating barriers increase insulation resistance and dielectric strength.

Constructed for dust resistance with interior seal of polyphenylene sulfide (PPS) between actuator and contact area.

Specially designed to break light contact welds.

Snap-action contact mechanism.

Terminals are molded in and epoxy sealed to lock out flux, dust, and other contaminants.

Outer case of heat resistant resin meet UL's 94V-0 flammability standard.

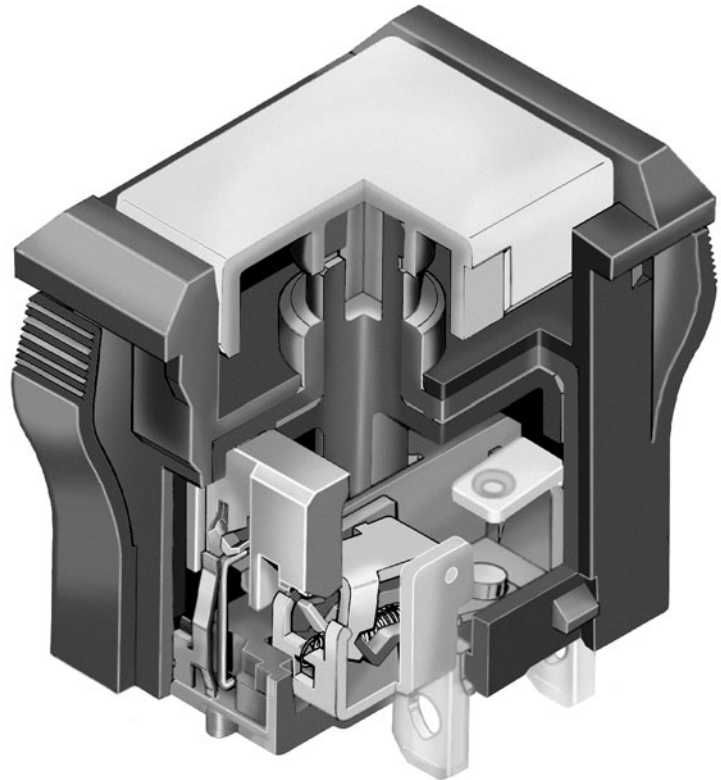

Actual Size JPM

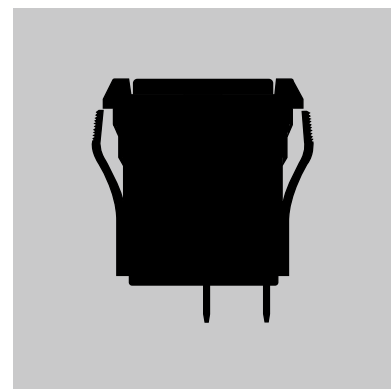

- Supplement
- Accessories
- Indicators
- Touch
- Tilt
- Tactiles
- Slides
- Rotaries
- Keylocks
- Programmable
- Illuminated PB
- Pushbuttons
- Rockers
- Toggles

TYPICAL SWITCH ORDERING EXAMPLE

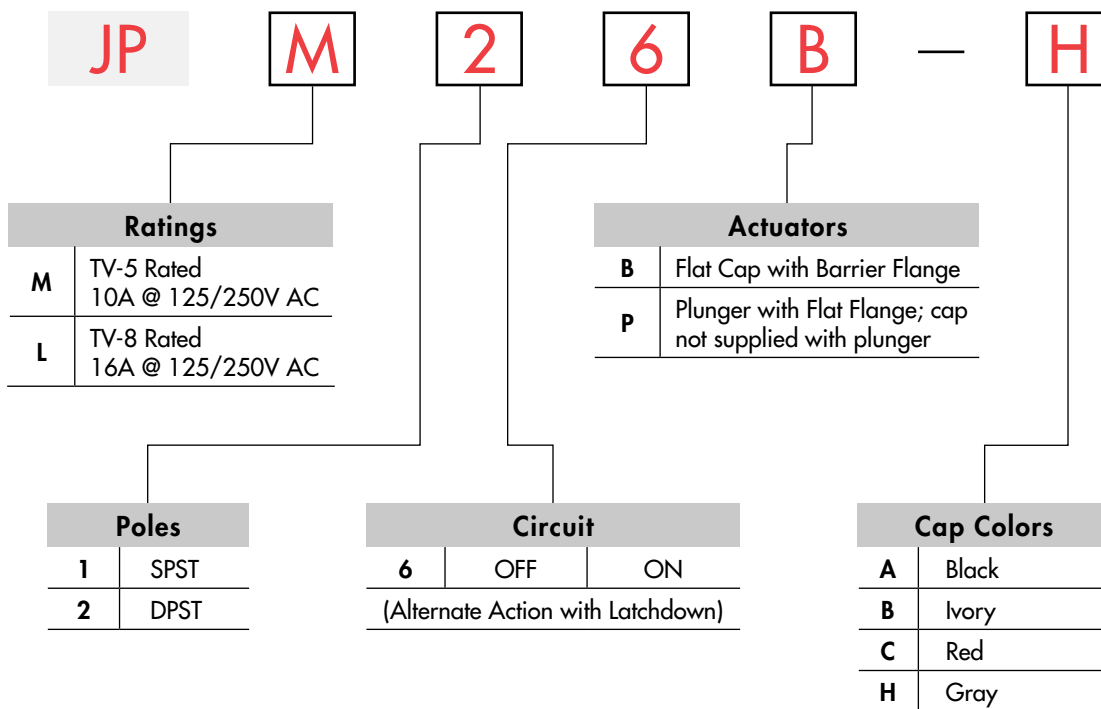

DESCRIPTION FOR TYPICAL ORDERING EXAMPLE

JPM26B-H

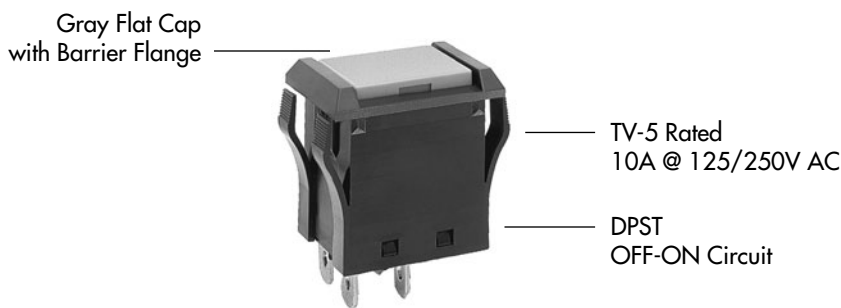

IMPORTANT:



Specific models & ratings for international approvals noted on General Specifications page.

Note: Wire harness & cable assemblies offered only in Americas

Toggles
Rocker
Pushbuttons
Illuminated PB
Programmable
Keylocks
Rotaries
Slides
Tactiles
Tilt
Touch
Indicators
Accessories
Supplement

RATINGS



TV-5 Rated

Power Level

10A @ 125/250V AC



TV-8 Rated

Power Level

16A @ 125/250V AC

Note: See General Specifications page to find complete explanation of TV ratings.

POLES & CIRCUIT

		Plunger Position		Connected Terminals		Throw & Schematics
Pole	Model	Normal	Down	Normal	Down	
						Note: Terminal numbers are actually on the switch.
SP	JPM16 JPL16	OFF	ON	OPEN	1-1a	SPST
DP	JPM26 JPL26	OFF	ON	OPEN	1-1a 2-2a	DPST

ACTUATORS



Flat Cap with Barrier Flange

The barrier is an integral part of the switch. This housing is black, molded polyamide matte finish material.

Cap details below.



Plunger with Flat Flange

The flange is an integral part of the switch. This housing is black, molded polyamide matte finish material.

No cap supplied.



CAP COLORS

AT3021 Flat Cap for Actuator Type B with Barrier Flange

Cap Material:
Polyphenylene Oxide

Finish: Matte

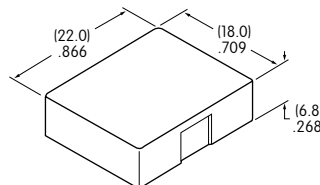

The cap is flush with the barrier in normal position and .079" (2.0mm) below that in latched position.

The latched feature on this alternate action device provides visible, audible, and tactile feedback. This design gives smooth, responsive operation.

Cap Colors Available:



Black



Ivory



Red



Gray

Toggle

Rockers

Pushbuttons

Programmable Illuminated PB

Keylocks

Rotaries

Slides

Tactiles

Tilt

Touch

Indicators

Accessories

Supplement

PANEL CUTOUT & TERMINALS

Panel Thickness Range applies to both JPM & JPL models.

.039" ~ .157"
(1.0mm ~ 4.0mm)

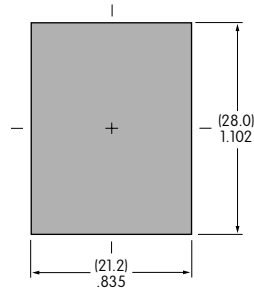

JPM & JPL Solder Lug/ .187" (4.75mm) Quick Connect Terminals

This switch assembly, when used with connectors, is not CSA approved.

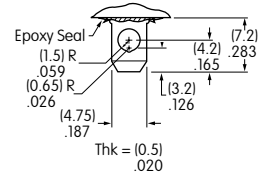

TYPICAL SWITCH DIMENSIONS

Flat Cap with Barrier Flange

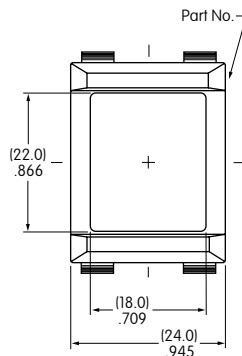

JPM26B-H

JPM & JPL Single & Double Pole

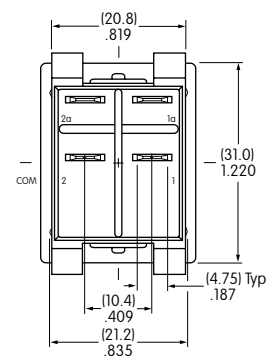
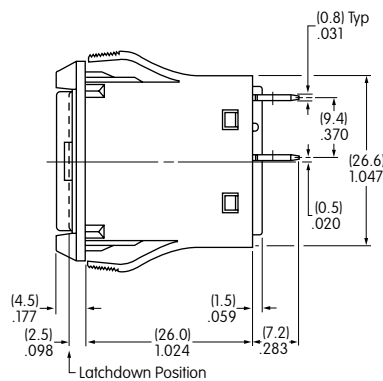

Single pole model does not have terminals 2 & 2a.

Plunger with Flat Flange

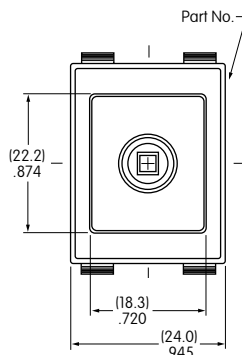

JPL16P

JPM & JPL Single & Double Pole

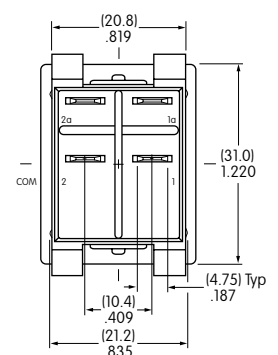
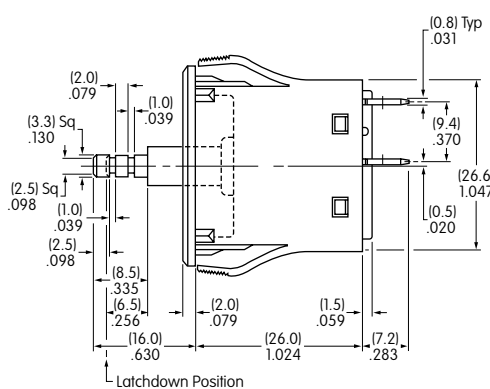

Single pole model does not have terminals 2 & 2a.

General Specifications

Electrical Capacity (Resistive Load)

Power Level (silver):	1A @ 125V AC or 1A @ 30V DC
Logic Level (gold):	0.4VA maximum @ 28V AC/DC maximum (Applicable Range 0.1mA ~ 0.1A @ 20mV ~ 28V)
Logic/Power Level: (gold over silver)	Combines silver & gold ratings

Note: Find additional explanation of dual rating & operating range in Supplement section.

Other Ratings

Contact Resistance:	20 milliohms maximum for silver; 30 milliohms maximum for gold
Insulation Resistance:	1,000 megohms minimum @ 500V DC
Dielectric Strength:	1,000V AC minimum between contacts for 1 minute minimum; 1,500V AC minimum between contacts & case for 1 minute minimum
Mechanical Life:	200,000 operations minimum
Electrical Life:	25,000 operations minimum for silver; 100,000 operations minimum for gold
Nominal Operating Force:	Single pole 2.94N & double pole 4.90N
Contact Timing:	Nonshorting (break-before-make)
Travel:	Pretravel .023" (0.6mm); Overtravel .016" (0.4mm); Total Travel .039" (1.0mm)

Materials & Finishes

Plunger:	Brass with nickel plating
Support Bracket:	Brass with tin plating
Bushing/Housing:	Glass fiber reinforced polyamide (UL94V-0)
Sealing Ring:	Nitrile butadiene rubber
Base:	Glass fiber reinforced polyamide (UL94V-0)
Movable Contacts:	Silver alloy with silver plating (code W); copper with gold plating (code G); or silver alloy with gold plating (code A)
Stationary Contacts:	Silver alloy with silver plating (code W); copper with gold plating (code G); or silver alloy with gold plating (code A)
Terminals:	Brass with silver or gold plating

Environmental Data

Operating Temp Range:	-30°C through +85°C (-22°F through +185°F)
Humidity:	90 ~ 95% humidity for 96 hours @ 40°C (104°F)
Vibration:	10 ~ 55Hz with peak-to-peak amplitude of 1.5mm traversing the frequency range & returning in 1 minute; 3 right angled directions for 2 hours
Shock:	50G (490m/s ²) acceleration (tested in 6 right angled directions, with 5 shocks in each direction)

Installation

Cap Installation Force:	49.0N (11.0 lbf) for plunger A & 79.4N (17.9 lbf) for plunger B
--------------------------------	---

PCB Processing

Soldering:	Wave Soldering Recommended: See Profile B in Supplement section. Manual Soldering: See Profile B in Supplement section.
Cleaning:	Automated cleaning. See Cleaning specifications in Supplement section.

Standards & Certifications

Flammability Standards:	UL94V-0 rated bushing/housing & base
UL:	File No. E44145 - Recognized only when ordered with marking on switch. Add "/U" or "/CUL" before dash in part number to order UL recognized switch. All models recognized at 1A @ 125V AC, 1A @ 30V DC, or 0.4A @ 28V DC.
CSA:	File No. 023535_0_000 - Certified only when ordered with marking on switch. Add "/C" before dash in part number to order CSA certified switch. All models certified at 1A @ 125V AC, 1A @ 30V DC, or 0.4A @ 28V DC.

Distinctive Characteristics

Snap-acting contact mechanism gives short travel, sensitive actuation, light touch, smooth feel, audible feedback, and a longer electrical life.

Single unit construction of the bushing and top of the housing gives protection from cleaning fluids or other liquids.

O-ring surrounding actuator at top of bushing interior prevents liquids from reaching switch mechanism.

Ultrasonic welding of upper and lower housing seals out contaminants and allows automated soldering and cleaning.

Terminals are epoxy sealed to prevent entry of flux, solvents, and other contaminants.

Bracketed models have crimped bracket legs to ensure secure PC mounting and prevent dislodging during automated soldering.

Logic level and power capabilities are available to suit varying applications.

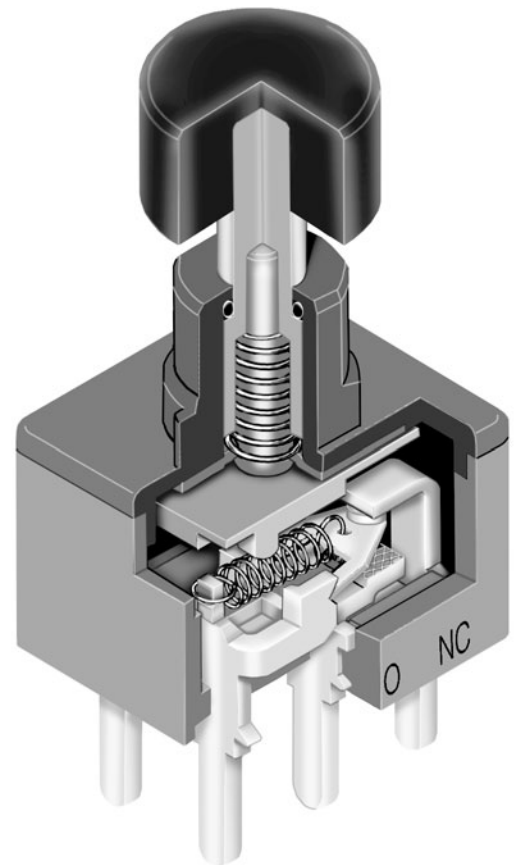

Actual Size

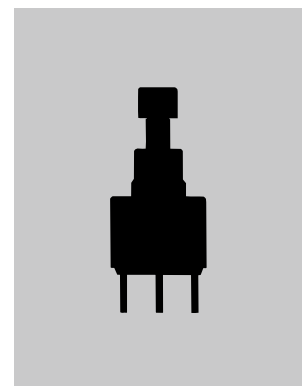

- Toggles
- Rockers
- Pushbuttons**
- Illuminated PB
- Programmable
- Keylocks
- Rotaries
- Slides
- Tactiles
- Tilt
- Touch
- Indicators
- Accessories
- Supplement

TYPICAL SWITCH ORDERING EXAMPLE

M2B

15

A

A5

G

30

F

C

Poles & Circuits

15	SPDT	ON	(ON)
25	DPDT	ON	(ON)
() = Momentary			

Plungers

A	.282" (7.16mm) Long for cap codes F & H
B	.307" (7.8mm) Long for cap codes B & C

Bushing

A5	.250" (6.35mm) Double Flatted
----	----------------------------------

Contact Materials & Ratings

W	Silver; Rated 1A @ 125V AC & 1A @ 30V DC
G	Gold; Rated 0.4VA maximum @ 28V AC/DC maximum
A	Gold over Silver; Rated 1A @ 125V AC & 0.4VA max @ 28V AC/DC max

PC Terminals

03	Straight
13	Straight with .460" (11.7mm) Bracket
30	.150" (3.81mm) Right Angle
40	.150" (3.81mm) Vertical

Snap-on Caps

For Plunger A	
F	.201" (5.1mm) Diameter
H	.295" (7.5mm) Diameter
For Plunger B	
B	.315" (8.0mm) Diameter
C	.394" (10.0mm) Diameter

Cap Colors

A	Black
B	White
C	Red
* E	Yellow
* F	Green
* G	Blue
* H	Gray
* For cap codes B & C only	

IMPORTANT:



Switches are supplied without UL, cULus & CSA marking unless specified. **UL, cULus & CSA recognized only when ordered with marking on the switch.** Specific models, ratings, & ordering instructions are noted on General Specifications page.



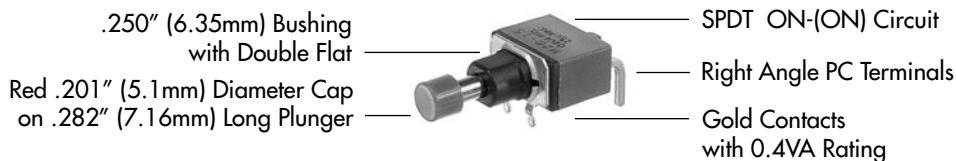

DESCRIPTION FOR TYPICAL ORDERING EXAMPLE

M2B15AA5G30-FC



Toggles
Rockers
Pushbuttons
Illuminated PB
Programmable
Keylocks
Rotaries
Slides
Tactiles
Tilt
Touch
Indicators
Accessories
Supplement

POLES & CIRCUITS

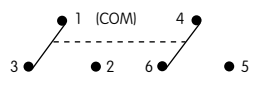
Pole	Model	Plunger Position () = Momentary		Connected Terminals		Throw & Schematics
		Normal	Down	Normal	Down	
						Note: Terminal numbers are not actually on the switch.
SP	M2B15	ON	(ON)	1-3	1-2	SPDT 
DP	M2B25	ON	(ON)	1-3 4-6	1-2 4-5	DPDT 

PLUNGERS

A .282" (7.16mm) Long

For cap codes F & H

Material:
Chrome over brass

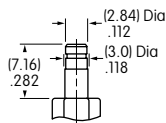

B .307" (7.8mm) Long

For cap codes B & C

Material:
Chrome over brass

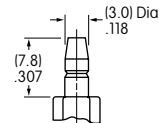

BUSHING

A5 .250" (6.35mm) Double Flatted

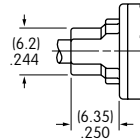
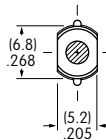

CONTACT MATERIALS & RATINGS

W Silver over Silver Power Level 1A @ 125V AC & 1A @ 30V DC

G Gold over Brass or Copper Logic Level 0.4VA maximum @ 28V AC/DC maximum

Complete explanation of operating range in Supplement section.

A Gold over Silver Power Level or Logic Level 1A @ 125V AC or 0.4VA maximum @ 28V AC/DC maximum

Note: This dual rated option is suitable when two or more identical switches are used in logic and in power circuits within the same application. See Supplement section for complete explanation of dual rating and operating range.

Toggles

Rockers

Pushbuttons

Illuminated PB

Programmable

Keylocks

Rotaries

Slides

Tactiles

Tilt

Touch

Indicators

Accessories

Supplement

PC TERMINALS

03 Straight

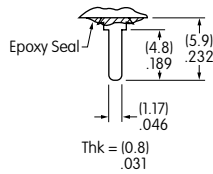

13 Straight with .460" (11.7mm) Bracket

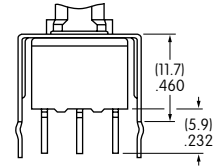

30 .150" (3.81mm) Right Angle

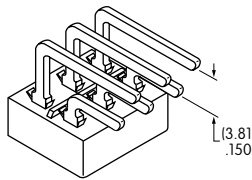

40 .150" (3.81mm) Vertical

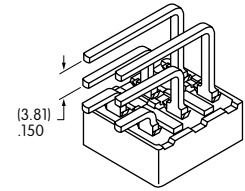

SNAP-ON CAPS

For Plunger Type A

F AT475
.201" (5.1mm) Diameter

Material: Polyamide

Colors Available:
A, B, C

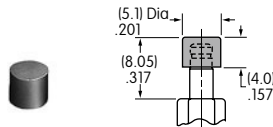

H AT496
.295" (7.5mm) Diameter

Material: Polyamide

Colors Available:
A, B, C

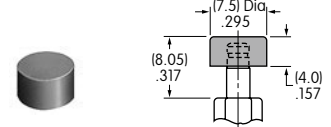

For Plunger Type B

B AT443
.315" (8.0mm) Diameter

Material: Polycarbonate

Colors Available:
A, B, C, E, F, G, H

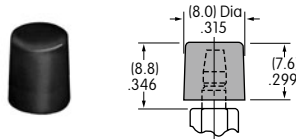

C AT442
.394" (10.0mm) Diameter

Material: Polycarbonate

Colors Available:
A, B, C, E, F, G, H

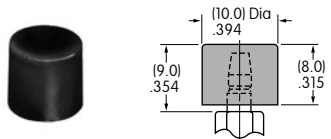

Cap Colors
Codes:

A Black **B** White **C** Red **E** Yellow **F** Green **G** Blue **H** Gray

TYPICAL SWITCH DIMENSIONS

Single Pole

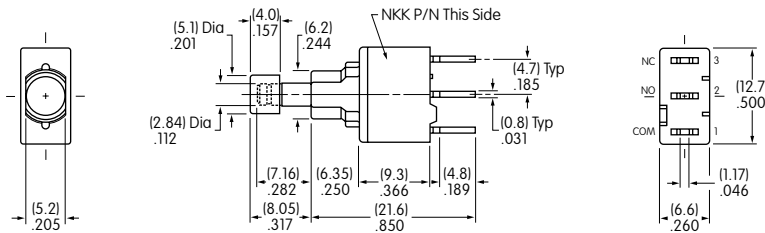

Straight PC

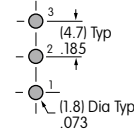

M2B15AA5G03-FC

Double Pole

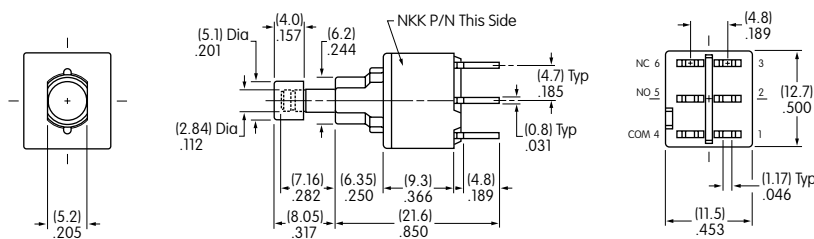

Straight PC

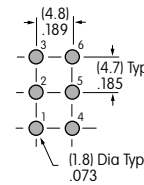

M2B25AA5G03-FC

Single & Double Pole

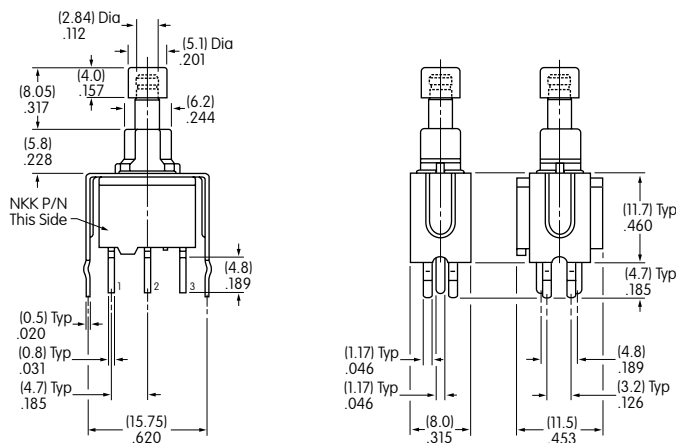

Straight PC • Bracket

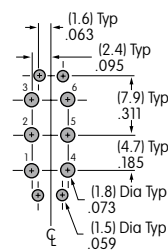
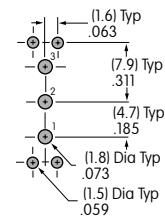

M2B15AA5G13-FC

TYPICAL SWITCH DIMENSIONS

Right Angle PC

Single Pole

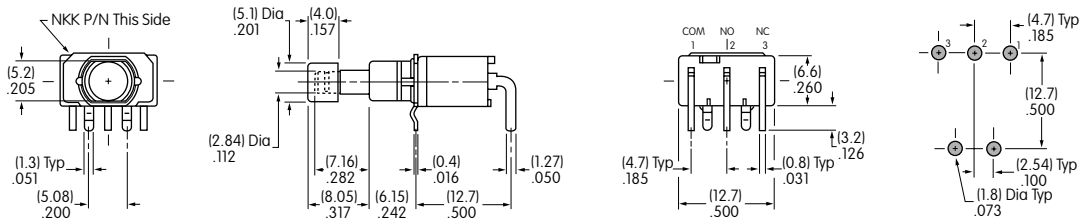

M2B15AA5G30-FC

Right Angle PC

Double Pole

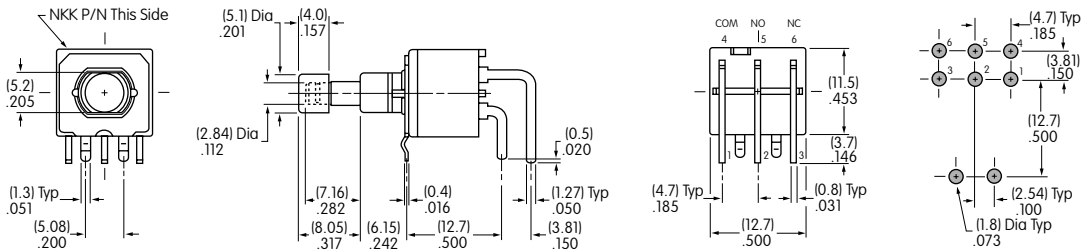

M2B25AA5G30-FC

Vertical PC

Single Pole

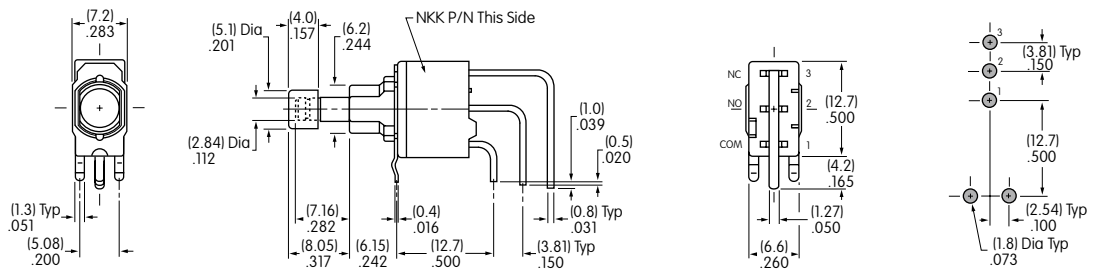

M2B15AA5G40-FC

Vertical PC

Double Pole

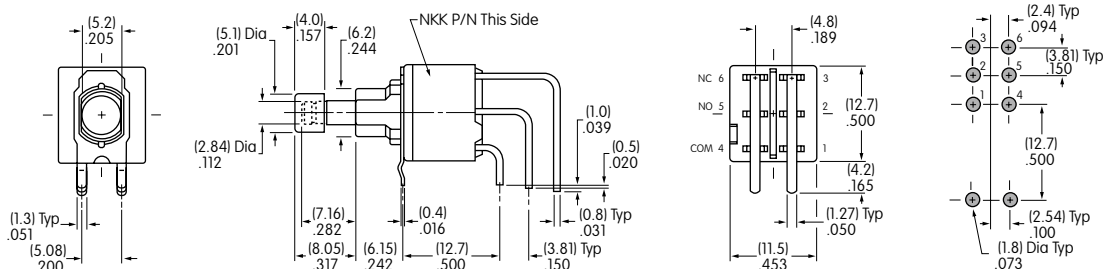

M2B25AA5G40-FC

General Specifications

Electrical Capacity (Resistive Load)

Power Level (silver):	6A @ 125V AC & 3A @ 250V AC or 3A @ 30V DC
Logic Level (gold):	0.4VA maximum @ 28V AC/DC maximum (Applicable Range 0.1mA ~ 0.1A @ 20mV ~ 28V)
Logic/Power Level: (gold over silver)	Combines silver & gold ratings

Note: Find additional explanation dual rating & operating range in Supplement section.

Other Ratings

Contact Resistance:	10 milliohms maximum for silver; 20 milliohms maximum for gold
Insulation Resistance:	1,000 megohms minimum @ 500V DC
Dielectric Strength:	1,000V AC minimum between contacts for 1 minute minimum; 1,500V AC minimum between contacts & case for 1 minute minimum
Mechanical Life:	50,000 operations minimum for splashproof models; 100,000 for all other models
Electrical Life:	25,000 operations minimum for silver; 50,000 operations minimum for gold 50,000 operations minimum for silver at 3A @ 125V AC
Nominal Operating Force:	Momentary Action: 1-pole 9.32N; 2-pole 16.18N; 4-pole 25.54N; Alternate Action: 1-pole 4.41N; 2-pole 7.06N; 4-pole 11.77N
Contact Timing:	Slow make, slow break
Plunger Travel:	Screw-on Cap (Mom.) Screw-on Cap (Alt.) Snap-on Cap (Mom. & Alt.)
Pretravel:	.028" (0.71mm) .110" (2.80mm) .125" (3.19mm)
Overtravel:	.043" (1.09mm) .043" (1.10mm) .050" (1.26mm)
Total Travel	.071" (1.80mm) .153" (3.90mm) .175" (4.45mm)

Materials & Finishes

Plunger:	Brass w/nickel plating; polyacetal w/B1 bushing	Bushing:	Brass with nickel plating
Frame:	Stainless steel	Case:	Diallyl phthalate resin (UL94V-0)
Movable Contactor:	Phosphor bronze with silver or gold plating		
Movable Contacts:	Silver alloy (code W); copper with gold plating (code G); or silver alloy with gold plating (code A)		
Stationary Contacts:	Silver with silver plating (code W); copper or brass with gold plating (code G); or silver with gold plating (code A)		
Terminals:	Copper or brass with silver plating; copper or brass with gold plating		

Environmental Data

Operating Temp Range:	-30°C through +85°C (-22°F through +185°F)
Humidity:	90 ~ 95% humidity for 96 hours @ 40°C (104°F)
Vibration:	10 ~ 55Hz with peak-to-peak amplitude of 1.5mm traversing the frequency range & returning in 1 minute; 3 right angled directions for 2 hours
Shock:	50G (490m/s ²) acceleration (tested in 6 right angled directions, with 5 shocks in each direction)
Sealing:	B3 & D3 bushing options equivalent to IP67

Installation

Mounting Torque:	1.5Nm (13.0 lb•in) for double nut; .7Nm (6.0 lb•in) for single nut
Cap Installation Force:	80.0N (18.0 lbf) maximum downward force on actuator
Soldering Time & Temp:	Wave Soldering (PC version): See Profile A in Supplement section. Manual Soldering: See Profile A in Supplement section.
Process Seal:	These devices are not process sealed. Hand clean locally using alcohol based solution.

Standards & Certifications

Flammability Standards:	UL94V-0 case
UL:	File No. E44145 - Recognized only when ordered with marking on switch. Add "/U" or "/CUL" before dash in part number to order UL recognized switch. All models recognized at 6A @ 125V AC or 3A @ 250V AC or 0.4VA max. @ 28V DC max.
CSA:	File No. 023535_0_000 - Certified only when ordered with marking on switch. Add "/C" before dash in part number to order CSA certified switch. All models certified at 6A @ 125V AC or 3A @ 250V AC or 0.4VA max. @ 28V max.

Distinctive Characteristics

Guide interlocked with actuator block prevents window locking and maintains correct plunger alignment to assure contact stability.

Employs an over-center actuator mechanism, which diminishes sparking and increases operating life in AC circuits.

High torque bushing construction prevents rotation or separation from frame during installation.

Splashproof option (D3 and B3 bushing codes) features an o-ring within the bushing and one under the face nut to protect from splashed, sprayed, or spilled liquids.

High insulating barriers, formed in the molded diallyl phthalate case, increase isolation of circuits in multipole devices.

Prominent external insulating barriers increase insulation resistance and dielectric strength.

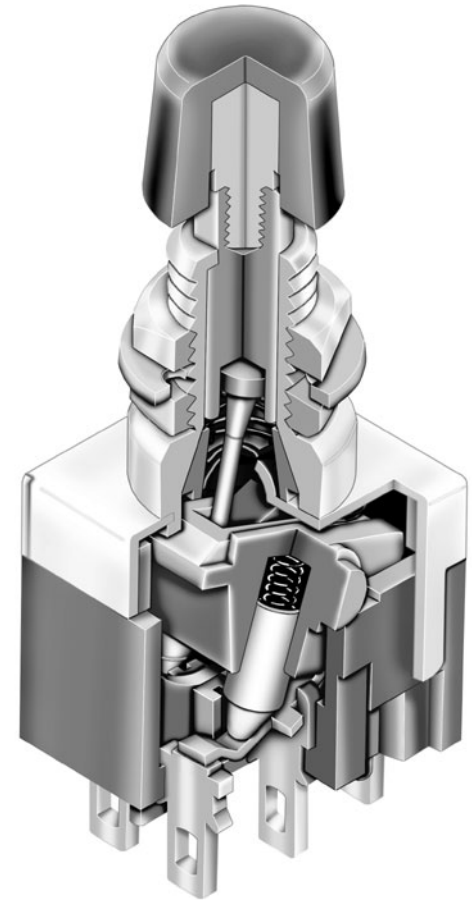

Epoxy sealed terminals prevent entry of solder flux and other contaminants.

Clinching of the frame to the case well above the base and terminals provides 1,500V dielectric strength.

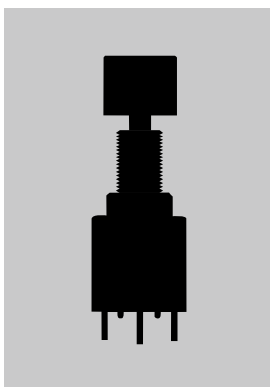

Actual Size



	Bushing Mount	Page C74
	Bracket PC Mount	Page C80
	Large Bushing	Page C87

- Toggle
- Rockers
- Pushbuttons**
- Illuminated PB
- Programmable
- Keylocks
- Rotaries
- Slides
- Tactiles
- Tilt
- Touch
- Indicators
- Accessories
- Supplement

TYPICAL SWITCH ORDERING EXAMPLE

MB **2011** **S** **S1** **W** **01** — **C** **A**

Poles & Circuits			
2011	SPDT	ON	(ON)
2065	SPDT	ON	ON
2061	DPDT	ON	(ON)
2085	DPDT	ON	ON
2181	4PDT	ON	(ON)
2185	4PDT	ON	ON

() = Momentary

Contact Materials & Ratings	
W	Silver Rated 6A @ 125V AC & 3A @ 250V AC
G	Gold Rated 0.4VA max @ 28V AC/DC max
A	Gold over Silver Rated 6A @ 125V AC & 0.4VA max @ 28V AC/DC max

Caps	
B	.315" (8.0mm) Diameter
C	.394" (10.0mm) Diameter

Cap Colors	
A	Black
B	White
C	Red
E	Yellow
F	Green
G	Blue
H	Gray

Plunger Types	
S	Plunger for Screw-on Caps
L	Plunger for Snap-on Caps

Bushings	
S1	.335" (8.5mm) Threaded with Keyway
S2	.335" (8.5mm) Smooth with Keyway
S4	.335" (8.5mm) Metric Threaded with Keyway
D1	.335" (8.5mm) Threaded with D-Flat
D3	.335" (8.5mm) Threaded Splashproof without Keyway

Terminals	
01	Solder Lug*
02	Quick Connect
03	.250" (6.35mm) Straight PC
05	.425" (10.8mm) Wirewrap
06	.750" (19.05mm) Wirewrap
07	.964" (24.5mm) Wirewrap
08	1.062" (27.0mm) Wirewrap

IMPORTANT:





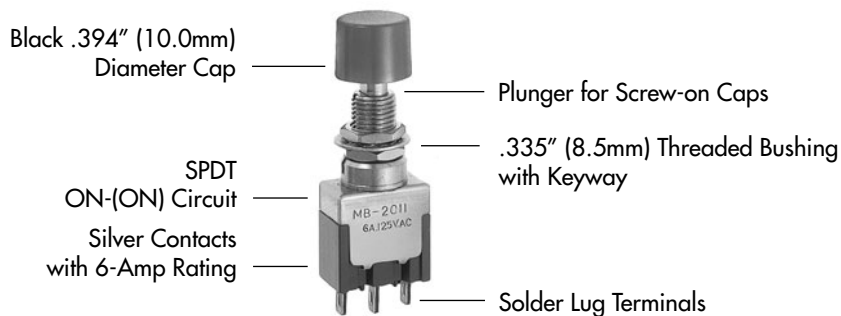

Switches are supplied without UL, cULus & CSA marking unless specified. **UL, cULus & CSA recognized only when ordered with marking on the switch.** Specific models, ratings, & ordering instructions are noted on General Specifications page.

DESCRIPTION FOR TYPICAL ORDERING EXAMPLE

MB2011SS1W01-CA

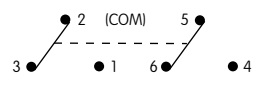
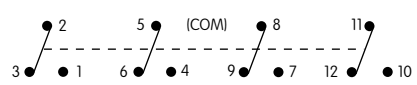

* Wire harness & cable assemblies offered only in Americas

POLES & CIRCUITS						
Pole	Model	Plunger Position () = Momentary		Connected Terminals		Throw & Switch Schematics
		Normal  Keyway	Down 	Normal  Keyway	Down 	
SP	MB2011	ON	(ON)	2-3	2-1	Note: Terminal numbers are not actually on the switch. 
	MB2065	ON	ON			
DP	MB2061	ON	(ON)	2-3 5-6	2-1 5-4	
	MB2085	ON	ON			
4P	MB2181	ON	(ON)	2-3 5-6	2-1 5-4	4PDT 
	MB2185	ON	ON	8-9 11-12	8-7 11-10	

PLUNGER TYPES

On alternate action models, after transferring circuit, the plunger returns to its original position and does not latch down.



Plunger for Screw-on Caps

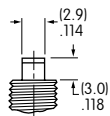

Momentary Plunger Length

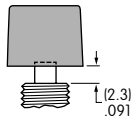

Momentary Cap Location

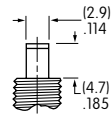

Alternate Plunger Length

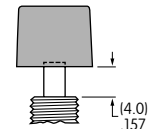

Alternate Cap Location



Plunger for Snap-on Caps

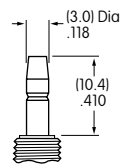

Momentary & Alternate Plunger Length

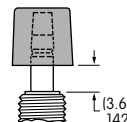

Momentary & Alternate Cap Location

BUSHINGS

S1 .335" (8.5mm)
Threaded with Keyway

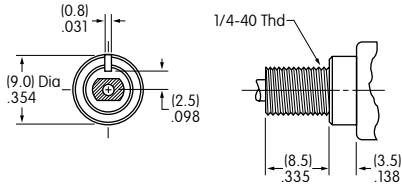

S2 .335" (8.5mm)
Smooth with Keyway

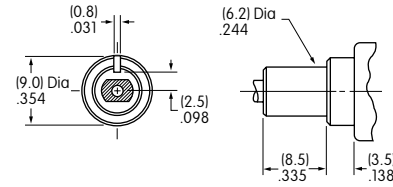

S4 .335" (8.5mm) Metric
Threaded with Keyway

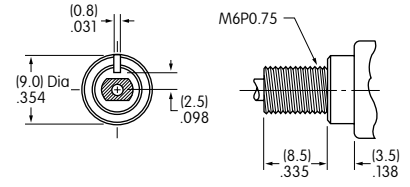

Maximum Panel Thickness with
Standard Hardware: .154" (3.9mm)

Maximum Panel Thickness with
Standard Hardware: .154" (3.9mm)

D1 .335" (8.5mm)
Threaded with D Flat

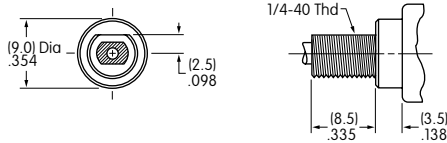

Maximum Panel Thickness with
Standard Hardware: .154" (3.9mm)

D3 .335" (8.5mm)
Threaded Splashproof without Keyway

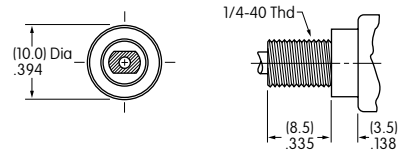

Maximum Panel Thickness with
Standard Hardware: .240" (6.1 mm)

Panel Cutouts

For S1, S2, or S4 Bushing
with
Keyway

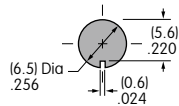

For S1 or S4 Bushing
with
Optional Locking Ring

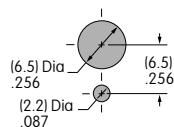

For D1 Bushing
with
D Flat

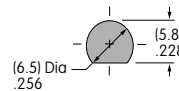

For D3 Bushing
without
Keyway

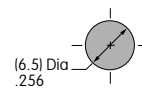

Standard hardware for bushings S1, S4, & D1 includes 2 hex nuts & 1 lockwasher; D3 bushing has 1 hex nut & 1 o-ring.
Standard & optional hardware are illustrated following the Typical Switch Dimension drawings.

CONTACT MATERIALS & RATINGS

W Silver over Silver Power Level 6A @ 125V AC & 3A @ 250V AC

G Gold over Brass or Copper Logic Level 0.4VA maximum @ 28V AC/DC maximum
Note: Complete explanation of operating range in Supplement section.

A Gold over Silver Power Level
or Logic Level 6A @ 125V AC & 3A @ 250V AC
or 0.4VA maximum @ 28V AC/DC maximum

Note: This dual rated option is suitable when two or more identical switches are used in logic and in power circuits within the same application. See Supplement section for complete explanation of dual rating and operating range.

TERMINALS

01 Solder Lug

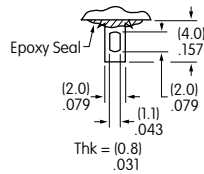

02 .062" (1.57mm) Wide Quick Connect

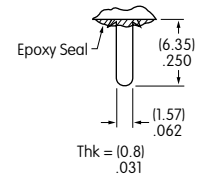

03 .250" (6.35mm) Straight PC

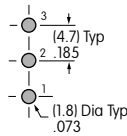
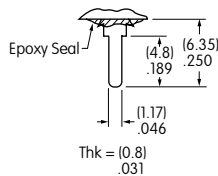

Single Pole

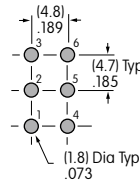

Double Pole

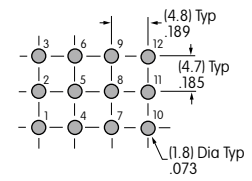

Four Pole

05 .425" (10.8mm) Wirewrap or Extended PC

06 .750" (19.05mm) Wirewrap or Extended PC

07 .964" (24.5mm) Wirewrap or Extended PC

08 1.062" (27.0mm) Wirewrap or Extended PC

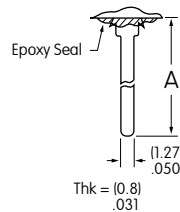

If using as extended PC terminal, refer to the above footprints.

Dimension A = terminal lengths as shown beside the terminal codes at the left.

CAPS & CAP COLORS

B AT413
.315" (8.0mm) Diameter
Screw-on Cap

AT443
.315" (8.0mm) Diameter
Snap-on Cap

C AT407
.394" (10.0mm) Diameter
Screw-on Cap

AT442
.394" (10.0mm) Diameter
Snap-on Cap

For use with Plunger Code S

For use with Plunger Code L

For use with Plunger Code S

For use with Plunger Code L

Cap Material: PBT
Finish: Glossy

Cap Material: Polycarbonate
Finish: Glossy

Cap Material: PBT
Finish: Glossy

Cap Material: Polycarbonate
Finish: Glossy

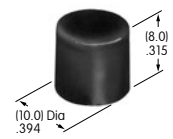
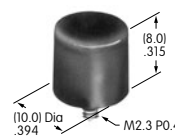
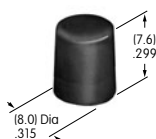
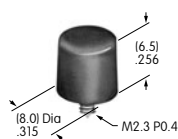

Cap Colors Available:

- A** Black
- B** White
- C** Red
- E** Yellow
- F** Green
- G** Blue
- H** Gray

TYPICAL SWITCH DIMENSIONS

Solder Lug

Single Pole

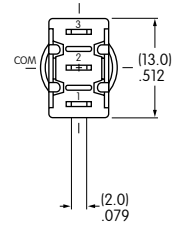
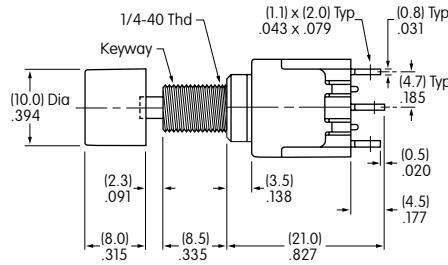
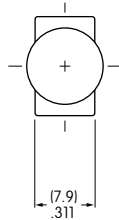

MB2011SS1W01-CA

Solder Lug

Double Pole

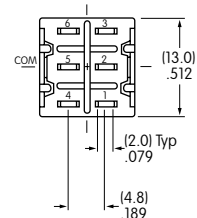
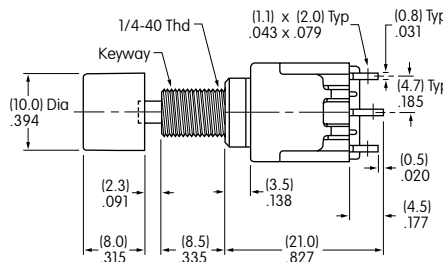
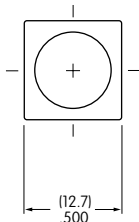

MB2061SS1W01-CA

Solder Lug

Four Pole

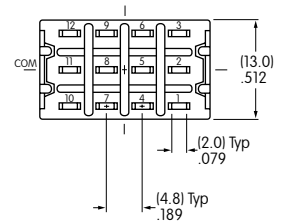
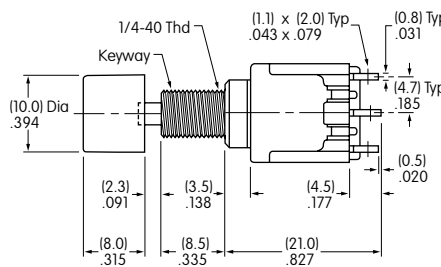
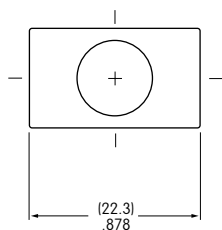

MB2181SS1W01-CA

HARDWARE

Standard Hardware

Optional Hardware

AT513H for Inch AT513M for Metric Hexagon Nut

2 included with each switch
(1 with splashproof models)

Material:
Brass with Nickel plating

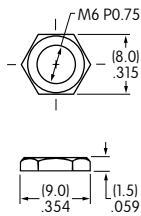

AT509 Lockwasher

1 included with each switch
(not with splashproof models)

Material:
Steel with Zinc/Chromate

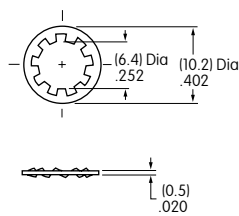

AT516 O-ring for Splashproof Bushing

1 included with
each splashproof model

Material:
Nitrile butadiene rubber

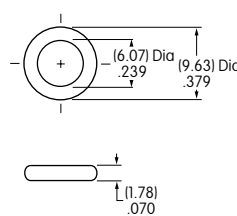

AT507H for Inch AT507M for Metric Locking Ring

Material:
Steel with Zinc/Chromate

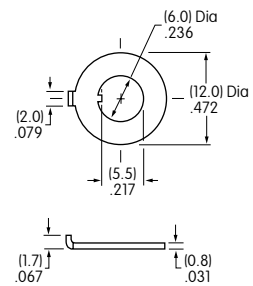

Optional Mounting Collars/Conical Nuts

Optional Splashproof Boots for S Plunger

AT512H for Inch AT512M for Metric Conical Nut

Used with .315" (8.0mm)
Diameter Cap (cap code B)
Material:
Brass with chrome plating

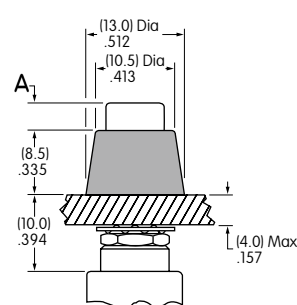

AT512CH for Inch AT512CM for Metric Conical nut

Used with .394" (10.0mm)
Diameter Cap (cap code C)
Material:
Brass with chrome plating

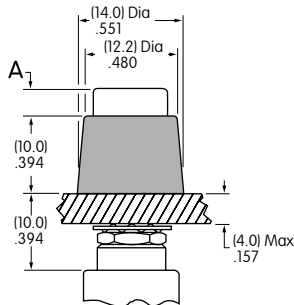

Dimension A = Cap Height

.091" (2.3mm) for Momentary with Plunger Code S
.157" (4.0mm) for Alternate with Plunger Code S
.142" (3.6mm) for Momentary & Alternate with Plunger Code L

AT4041H for Inch AT4041M for Metric Boot for Momentary

Material:
Silicone rubber



Operating Life 100,000

Boots for momentary devices
are accompanied by a threaded
adaptor which extends the length
of the plunger.

AT4042H for Inch AT4042M for Metric Boot for Alternate

Material:
Silicone rubber

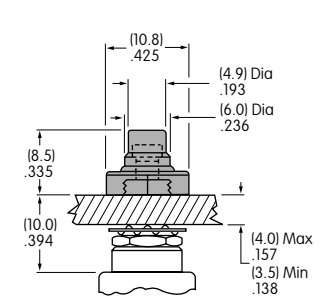

Operating Life 30,000

TYPICAL SWITCH ORDERING EXAMPLE

MB 2011 S S2 G 13 — C A

Poles & Circuits			
2011	SPDT	ON	(ON)
2065	SPDT	ON	ON
2061	DPDT	ON	(ON)
2085	DPDT	ON	ON
2181	4PDT	ON	(ON)
2185	4PDT	ON	ON
() = Momentary			
4-pole not for use with right angle terminals			

Contact Materials & Ratings	
W	Silver Rated 6A @ 125V AC & 3A @ 250V AC
G	Gold Rated 0.4VA max @ 28V AC/DC max
A	Gold over Silver Rated 6A @ 125V AC & 0.4VA max @ 28V AC/DC max

Caps	
B	.315" (8.0mm) Diameter
C	.394" (10.0mm) Diameter

Cap Colors	
A	Black
B	White
C	Red
E	Yellow
F	Green
G	Blue
H	Gray

Plunger Type	
S	Plunger for Screw-on Caps

Bushings	
S2	.335" (8.5mm) Smooth with Keyway
S1	.335" (8.5mm) Threaded with Keyway
A2	.200" (5.08mm) Smooth with Keyway Only Available in Part Numbers MB2011SA2G31 & MB2011SA2W31

Terminals	
13	.250" (6.35mm) Straight PC with Bracket
40	.150" (3.81mm) Vertical PC
45	.100" (2.54mm) Vertical PC
30	Right Angle PC with .646" (16.4mm) Support to Terminals Available in 1- & 2-pole only
31	Right Angle PC with .500" (12.7mm) Support to Terminals Available in 1-pole only

IMPORTANT:

Switches are supplied without UL, cULus & CSA marking unless specified. **UL, cULus & CSA recognized only when ordered with marking on the switch.** Specific models, ratings, & ordering instructions are noted on General Specifications page.







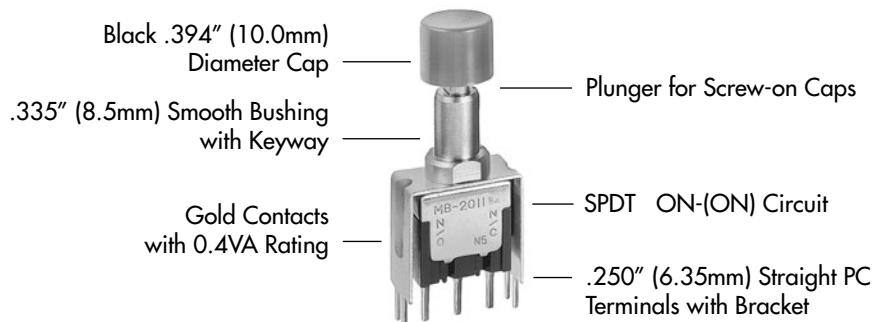









DESCRIPTION FOR TYPICAL ORDERING EXAMPLE

MB2011SS2G13-CA

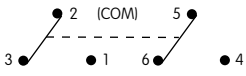

POLES & CIRCUITS

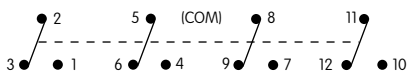
Pole	Model	Plunger Position () = Momentary		Connected Terminals		Throw & Switch Schematics
		Normal 	Down 	Normal 	Down 	
SP	MB2011 MB2065	ON 	(ON) ON	2-3 	2-1 	SPDT Note: Terminal numbers are not actually on the switch. 
DP	MB2061 MB2085	ON 	(ON) ON	2-3 5-6 	2-1 5-4 	DPDT 
4P	MB2181 MB2185	ON 	(ON) ON	2-3 5-6 8-9 11-12 	2-1 5-4 8-7 11-10 	4PDT 

PLUNGER TYPE

On alternate action models, after transferring circuit, the plunger returns to its original position and does not latch down.

S

Plunger for Screw-on Caps

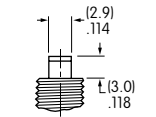

Momentary Plunger Length

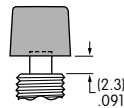

Momentary Cap Location

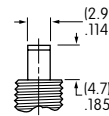

Alternate Plunger Length

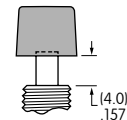

Alternate Cap Location

BUSHINGS

S2

.335" (8.5mm)
Smooth with Keyway

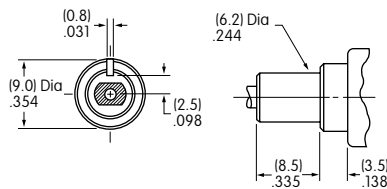

S1

.335" (8.5mm)
Threaded with Keyway

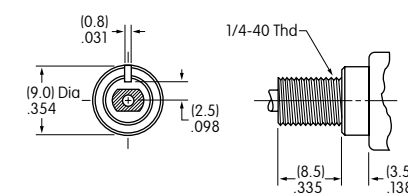

A2

.200" (5.08mm)
Smooth with Keyway

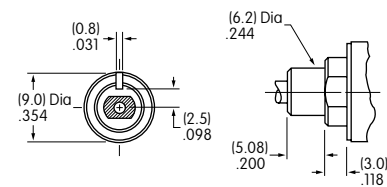

Standard hardware: 2 hex nuts (AT513H)
& 1 lockwasher (AT509)
Optional hardware: Locking ring (AT507)

Only available in part numbers
MB2011SA2W31 & MB2011SA2G31

Panel Cutouts

For S2, S1, or A2 Bushing
with Keyway

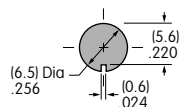

With Optional
Locking Ring

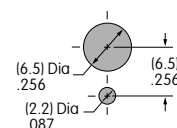

Maximum Panel Thickness with
Standard Hardware: .154" (3.9mm)

CONTACT MATERIALS & RATINGS

W	Silver over Silver	Power Level	6A @ 125V AC & 3A @ 250V AC
G	Gold over Brass or Copper	Logic Level	0.4VA maximum @ 28V AC/DC maximum Note: Complete explanation of operating range in Supplement section.
A	Gold over Silver	Power Level or Logic Level	6A @ 125V AC & 3A @ 250V AC or 0.4VA maximum @ 28V AC/DC maximum Note: This dual rated option is suitable when two or more identical switches are used in logic and in power circuits within the same application. See Supplement section for complete explanation of dual rating and operating range.

TERMINALS

13	.250" (6.35mm) Straight PC with Bracket	40	.150" (3.81mm) Vertical PC	45	.100" (2.54mm) Vertical PC
30	Right Angle PC with .646" (16.4mm) Support to Terminal	31	Right Angle PC with .500" (12.7mm) Support to Terminal		

Only Available in 1 & 2 Pole

Note: Full dimensioned drawings appear on the following pages.

CAPS & CAP COLORS

B	AT413 .315" (8.0mm) Diameter Screw-on Cap		C	AT407 .394" (10.0mm) Diameter Screw-on Cap	
Cap Material: PBT Finish: Glossy			Cap Material: PBT Finish: Glossy		

Cap Colors Available: **A** Black **B** White **C** Red **E** Yellow **F** Green **G** Blue **H** Gray

Toggles
Rockers
Pushbuttons
Illuminated PB
Programmable
Keylocks
Rotaries
Slides
Tactiles
Tilt
Touch
Indicators
Accessories
Supplement

TYPICAL SWITCH DIMENSIONS

Single Pole

Straight PC with Bracket

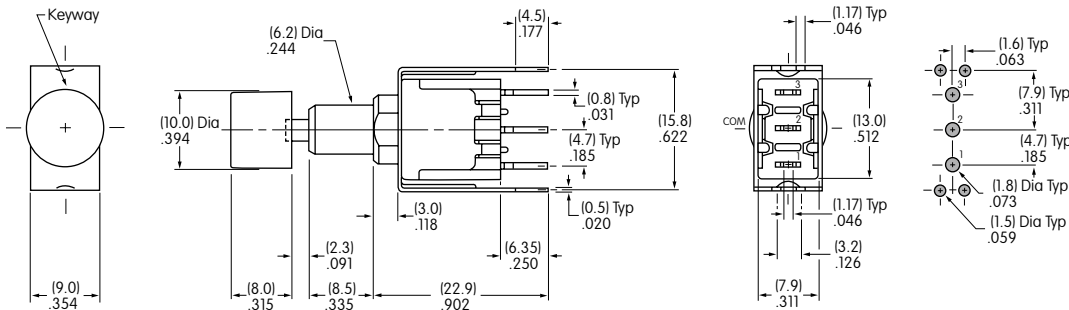

MB2011SS2G13-CA

Double Pole

Straight PC with Bracket

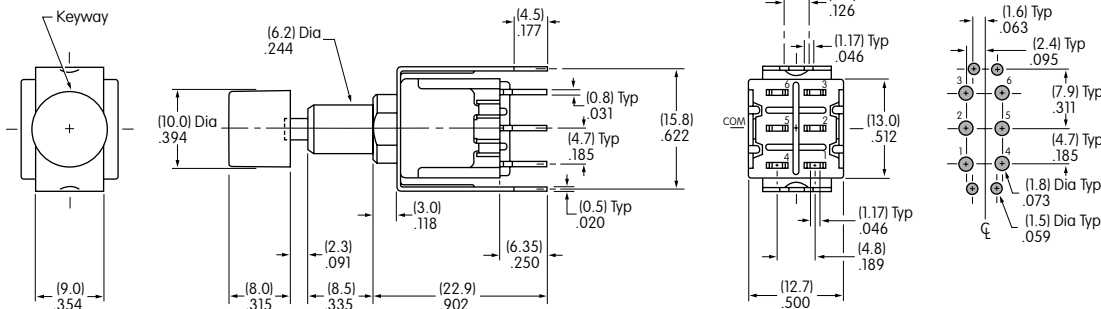

MB2061SS2G13-CA

Four Pole

Straight PC with Bracket

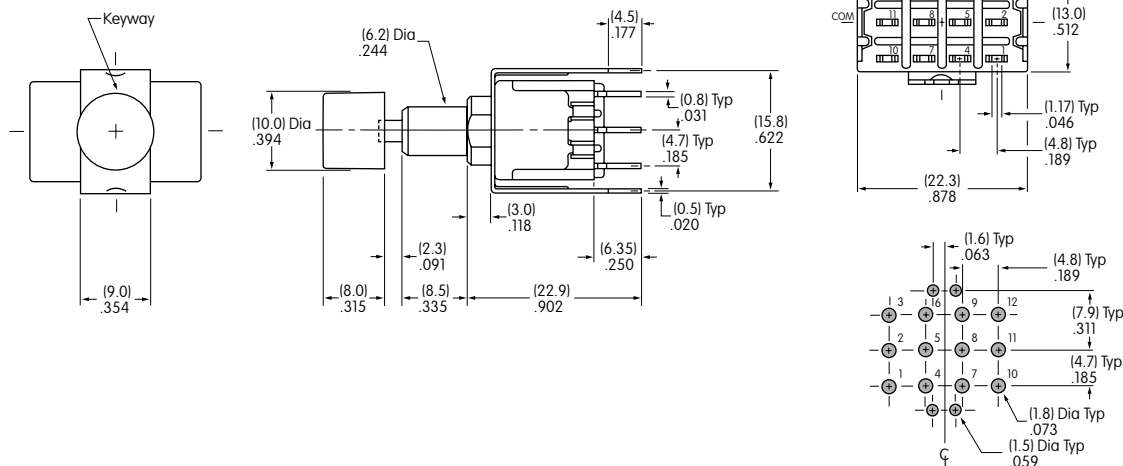

MB2181SS2G13-CA

- Toggle
- Rockers
- Pushbuttons**
- Illuminated PB
- Programmable
- Keylocks
- Rotaries
- Slides
- Tactiles
- Tilt
- Touch
- Indicators
- Accessories
- Supplement

TYPICAL SWITCH DIMENSIONS

.150" (3.81mm) Vertical PC

Single Pole

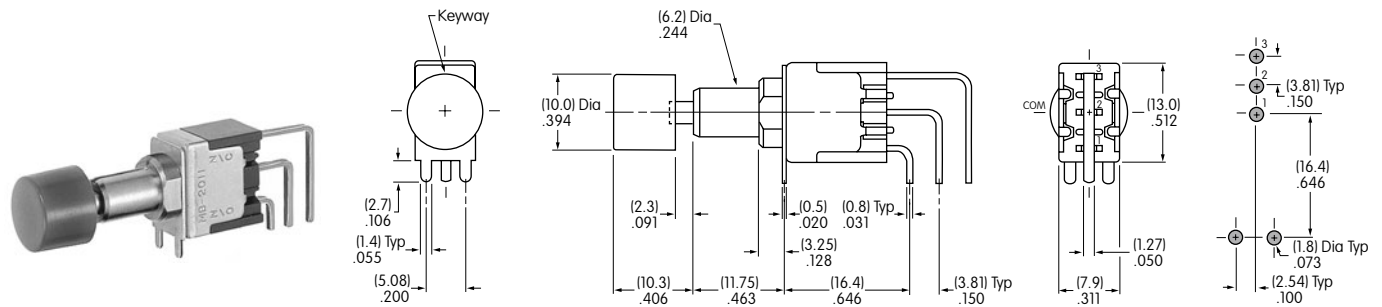

MB2011SS2G40-CA

.150" (3.81mm) Vertical PC

Double Pole

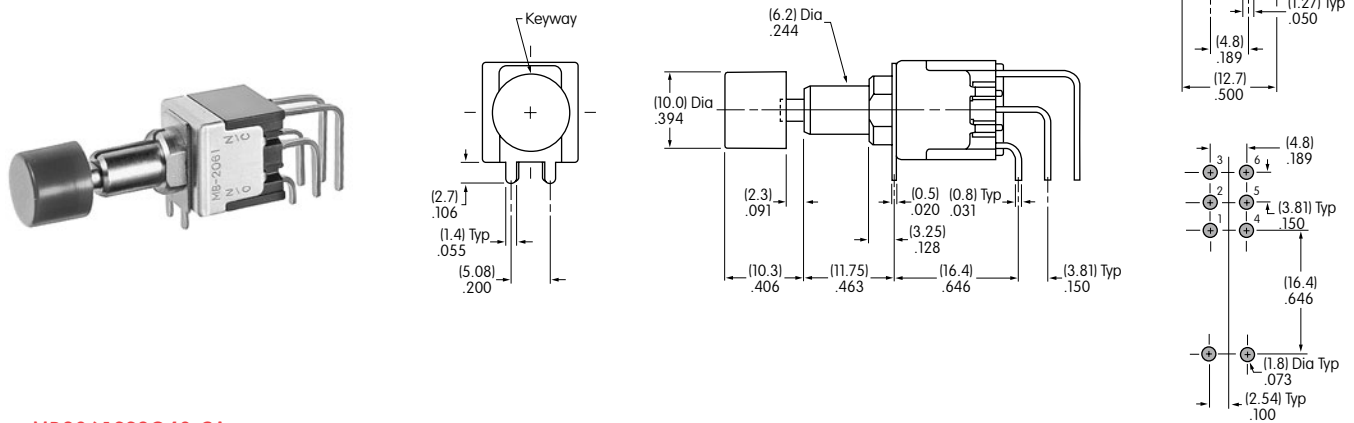

MB2061SS2G40-CA

.150" (3.81mm) Vertical PC

Four Pole

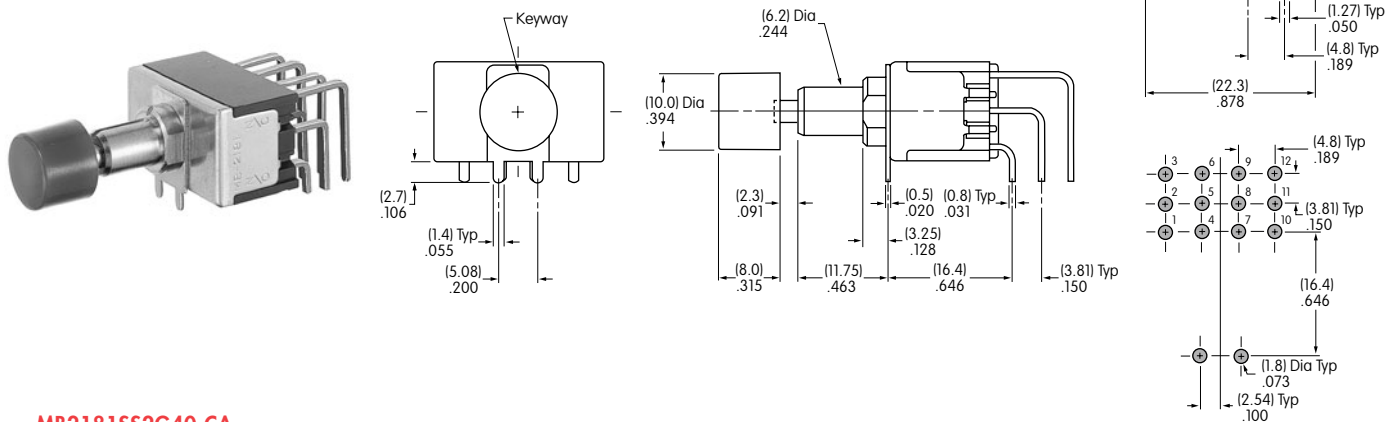

MB2181SS2G40-CA

TYPICAL SWITCH DIMENSIONS

Single Pole

.100" (2.54mm) Vertical PC

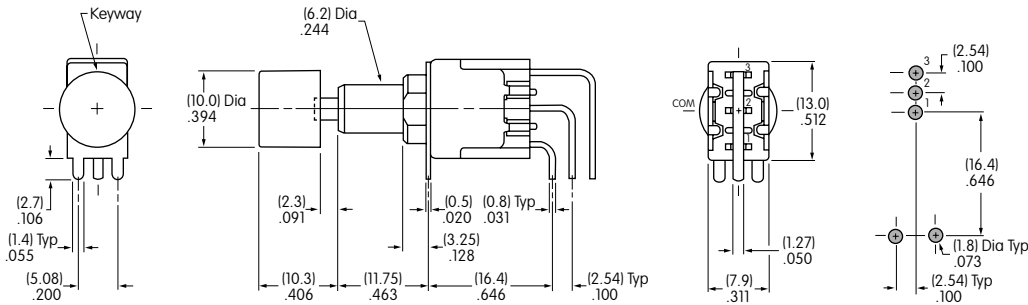

MB2011SS2G45-CA

Double Pole

.100" (2.54mm) Vertical PC

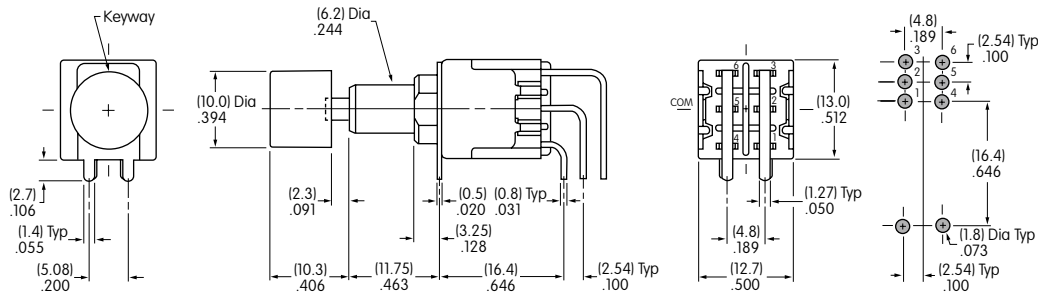

MB2061SS2G45-CA

Four Pole

.100" (2.54mm) Vertical PC

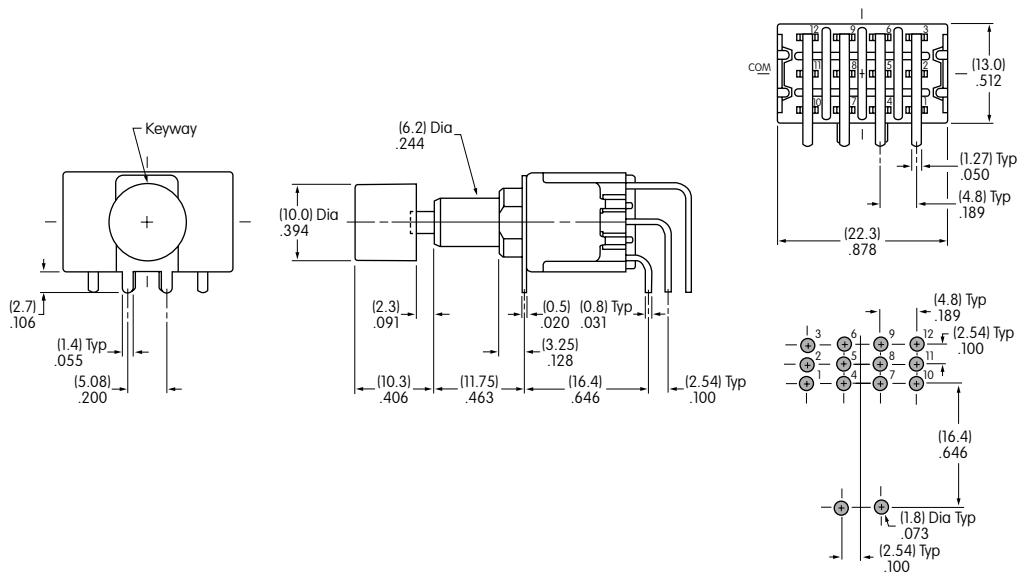

MB2181SS2G45-CA

- Toggle
- Rockers
- Pushbuttons**
- Illuminated PB
- Programmable
- Keylocks
- Rotaries
- Slides
- Tactiles
- Tilt
- Touch
- Indicators
- Accessories
- Supplement

TYPICAL SWITCH DIMENSIONS

Right Angle PC

Single Pole

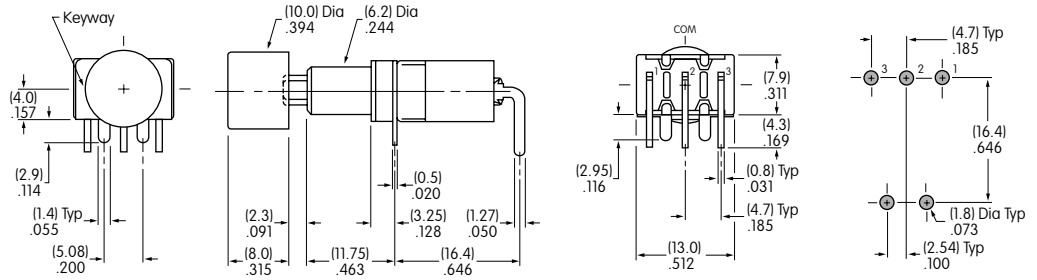

MB2011SS2G30-CA

Right Angle PC

Double Pole

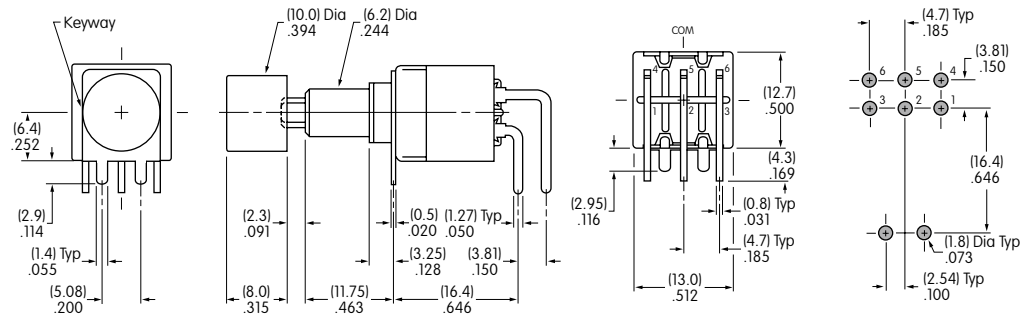

MB2061SS2G30-CA

Right Angle PC with .500" (12.7mm) Support to Terminal

Single Pole

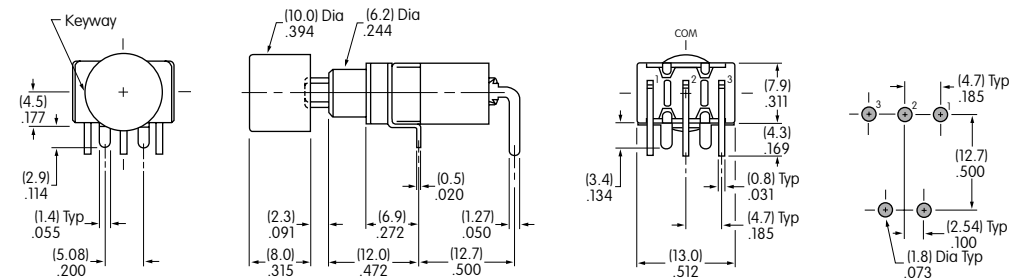

MB2011SA2G31-CA

Toggles
Rockers
Pushbuttons
Illuminated PB
Programmable
Keylocks
Rotaries
Slides
Tactiles
Tilt
Touch
Indicators
Accessories
Supplement

TYPICAL SWITCH ORDERING EXAMPLE

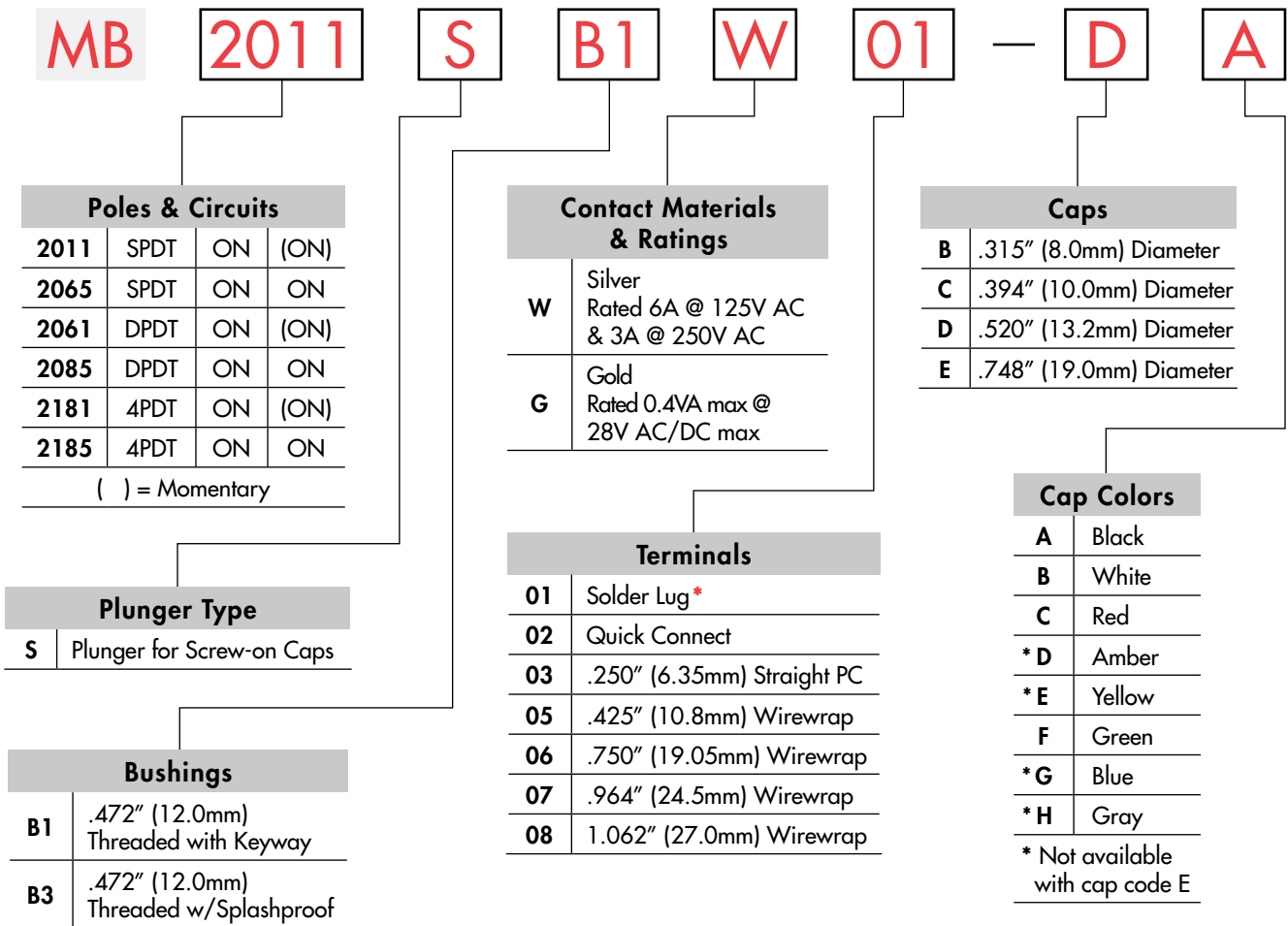

* Wire harness & cable assemblies offered only in Americas

IMPORTANT:



Switches are supplied without UL, cULus & CSA marking unless specified. **UL, cULus & CSA recognized only when ordered with marking on the switch.** Specific models, ratings, & ordering instructions are noted on General Specifications page.

DESCRIPTION FOR TYPICAL ORDERING EXAMPLE

MB2011SB1W01-DA

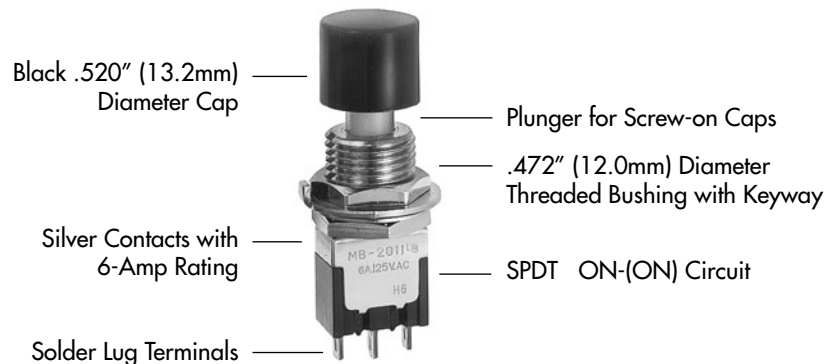

Toggles

Rockers

Pushbuttons

Illuminated PB

Programmable

Keylocks

Rotaries

Slides

Tactiles

Tilt





Touch

Indicators

Accessories

Supplement

POLES & CIRCUITS

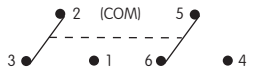
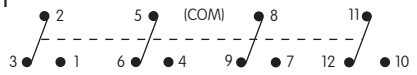
		Plunger Position () = Momentary		Connected Terminals		Throw & Switch Schematics
Pole	Model	Normal 	Down 	Normal 	Down 	Note: Terminal numbers are not actually on the switch.
SP	MB2011 MB2065	ON	(ON)	2-3	2-1	SPDT 
DP	MB2061 MB2085	ON	(ON)	2-3 5-6	2-1 5-4	DPDT 
4P	MB2181 MB2185	ON	(ON)	2-3 5-6 8-9 11-12	2-1 5-4 8-7 11-10	4PDT 

PLUNGER TYPE

S

Plunger for Screw-on Caps
Plunger is plastic for B1 bushing.

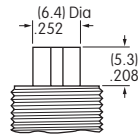

Plunger is metal for B3 bushing.

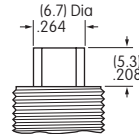

On alternate action models, after transferring circuit, the plunger returns to its original position, and does not latch down.

BUSHINGS

B1

.472" (12.0mm) Diameter Threaded with Keyway

Maximum Panel Thickness with Standard Hardware: .217" (5.5mm)

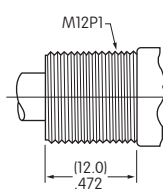
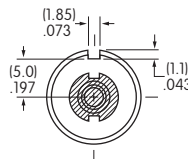

B3

.472" (12.0mm) Diameter Threaded Splashproof

Maximum Panel Thickness with Standard Hardware: .217" (5.5mm)

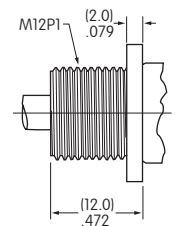
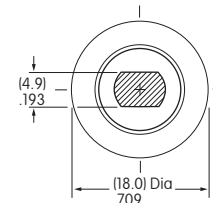

Panel Cutouts

For B1 Bushing with Keyway

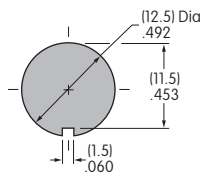

For B1 Bushing with Locking Ring

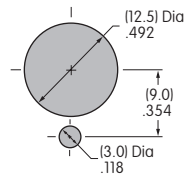

For B3 Bushing without Keyway

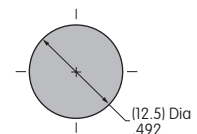

CONTACT MATERIALS & RATINGS

W

Silver over Silver

Power Level

6A @ 125V AC & 3A @ 250V AC

G

Gold over Brass or Copper

Logic Level

0.4VA maximum @ 28V AC/DC maximum

Note: Complete explanation of operating range in Supplement section.

TERMINALS

01 Solder Lug

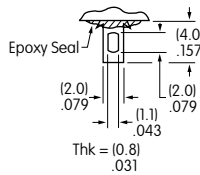

02 .062" (1.57mm) Wide Quick Connect

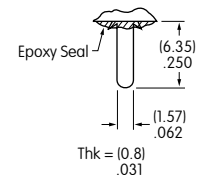

03 .250" (6.35mm) Straight PC

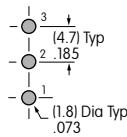
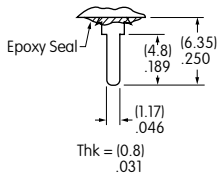

Single Pole

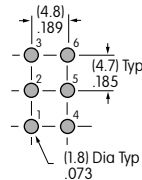

Double Pole

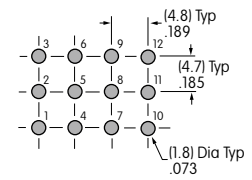

Four Pole

05 .425" (10.8mm) Wirewrap or Extended PC

06 .750" (19.05mm) Wirewrap or Extended PC

07 .964" (24.5mm) Wirewrap or Extended PC

08 1.062" (27.0mm) Wirewrap or Extended PC

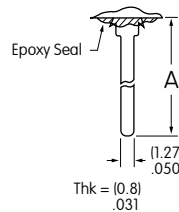

If using as extended PC terminal, refer to the above footprints.

Dimension A = terminal lengths as shown beside the terminal codes at the left.

CAPS & CAP COLORS

B AT078
.315" (8.0mm)
Diameter Screw-on Cap

C AT079
.394" (10.0mm)
Diameter Screw-on Cap

D AT414
.520" (13.2mm)
Diameter Screw-on Cap

E AT412
.748" (19.0mm)
Diameter Screw-on Cap

Material:
Polystyrene
Finish:
Glossy



Material:
Polystyrene
Finish:
Glossy



Material:
PBT
Finish:
Glossy



Material:
Polystyrene
Finish:
Glossy



Colors Available:
A B C E F G H

Colors Available:
A B C E F G H

Colors Available:
A B C D E F G H

Colors Available:
A B C F

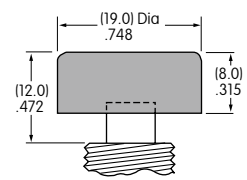
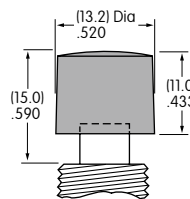
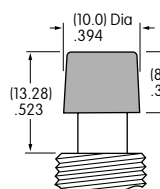
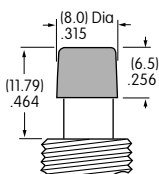

Cap Color
Codes:

A Black **B** White **C** Red **D** Amber **E** Yellow **F** Green **G** Blue **H** Gray

TYPICAL SWITCH DIMENSIONS

Solder Lug

Single Pole

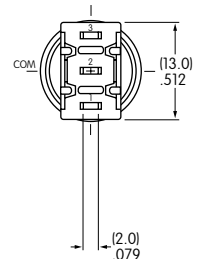
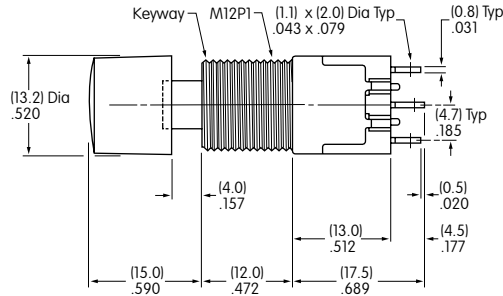
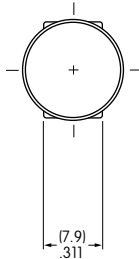

MB2011SB1W01-DA

Solder Lug

Double Pole

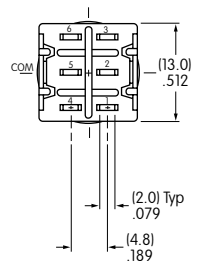
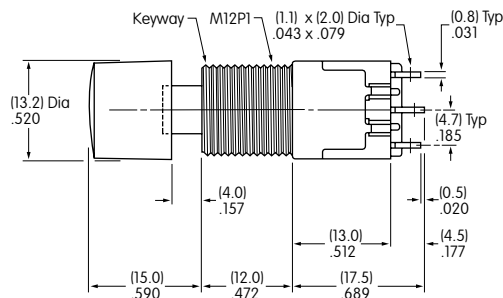
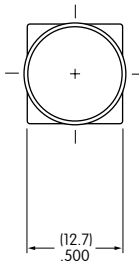

MB2061SB1W01-DA

Solder Lug

Four Pole

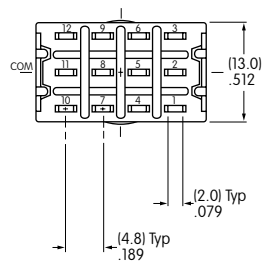
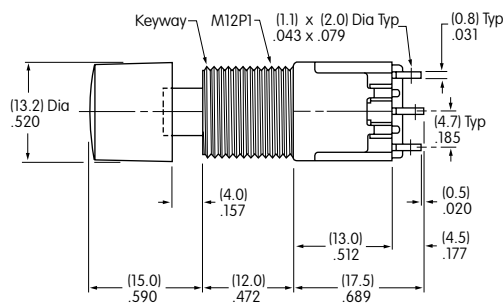
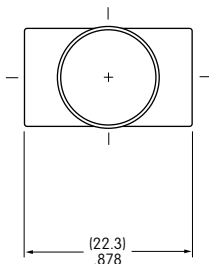

MB2181SB1W01-DA

HARDWARE

Standard Hardware for B1 Bushing

AT503M Hex Face Nut

Material:
Brass with Chrome plating

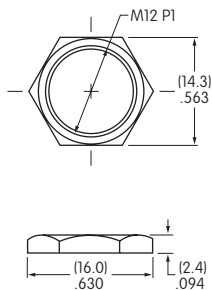

AT508 Lockwasher

Material:
Steel with Zinc/Chromate

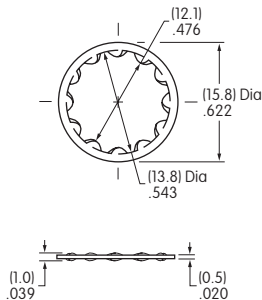

AT527M Hex Nut

Material:
Steel with Nickel plating

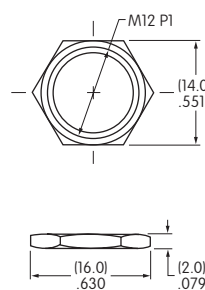

AT506M Locking Ring

Material:
Steel with Zinc/Chromate

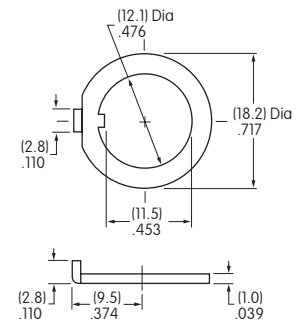

Standard Hardware for B3 Bushing

AT503M Hex Face Nut

Material:
Brass with Chrome plating

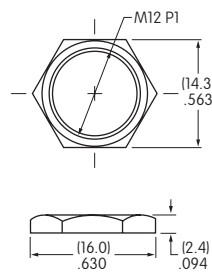

AT401P O-ring

Material:
Nitrile butadiene rubber

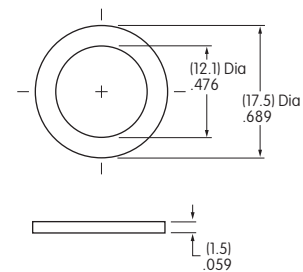

Optional Splashproof Boot for B1 Bushing

AT4043 Splashproof Boot

Material: Silicone Rubber
Operating Life: 10,000 for momentary
30,000 for alternate action

When using a splashproof boot, no cap is required.

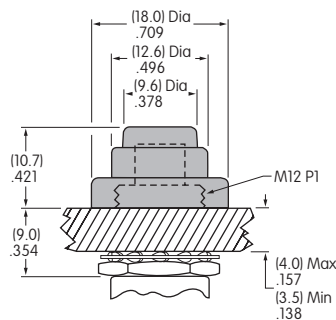

CUSTOM ASSEMBLY ORDERING EXAMPLE

The MB2000 pushbutton series offers flexibility to accommodate a variety of applications. Using a basic large bushing model, different accessories can be assembled onto the switch to achieve the mounting variations shown on the following two pages.

- These switches have:
- 12mm diameter threaded bushing with keyway
 - Silver contacts
 - 6-Amp rating
 - Solder lug terminals

Other 12mm bushing options can be used; see details in preceding Large Bushing Ordering tables.

MB2011

SB1W01

4

C

A

Poles & Circuits			
2011	SPDT	ON	(ON)
2065	SPDT	ON	ON
2061	DPDT	ON	(ON)
2085	DPDT	ON	ON
4-pole available			
() = Momentary			

Mounter Shapes For Shroud	
4	Round
5	Rectangular

Cap Colors For Shroud	
A	Black
B	White
C	Red
F	Green
G	Blue
H	Gray

Mounter Colors For Shroud	
A	Black
B	White
H	Gray

Cap Colors For Snap-In	
A	Black
B	White
C	Red
F	Green



Round Shroud
MB2011SB1W01-4C-A



Rectangular Shroud
MB2011SB1W01-5C-A

See custom assemblies on following pages.

Toggles
 Rockers
 Pushbuttons
 Illuminated PB
 Programmable
 Keylocks
 Rotaries
 Slides
 Tactiles
 Tilt
 Touch
 Indicators
 Accessories
 Supplement

MOUNTER SHAPES FOR SHROUDS

4 AT455 Round

Material: Polycarbonate
Colors: A B H



5 AT453 Rectangular

Material: Polycarbonate
Colors: A B H



CAPS & CAP COLORS FOR SHROUDS

AT454 Round
Insert Cap

Material: Polycarbonate
Colors: A B C F G H



AT452 Rectangular
Insert Cap

Material: Polycarbonate
Colors: A B C F G H

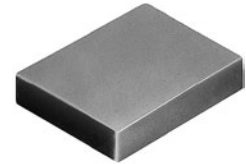

AT080 Screw Adaptor for Insert Caps

Material: Brass



Color Codes:

- A** Black
- B** White
- C** Red
- F** Green
- G** Blue
- H** Gray

Toggles

Rockers

C Pushbuttons

Illuminated PB

Programmable

Keylocks

Rotaries

Slides

Tactiles

Tilt

Touch

Indicators

Accessories

Supplement

CUSTOM ASSEMBLY WITH ROUND SHROUD



MB2011SB1W01-4C-A

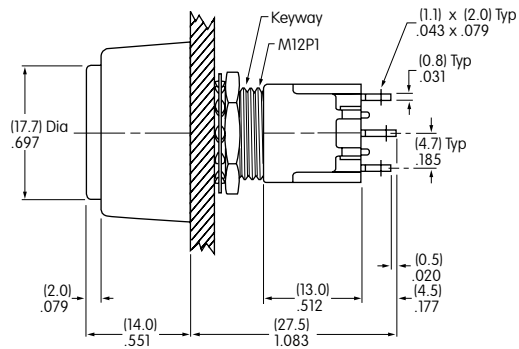
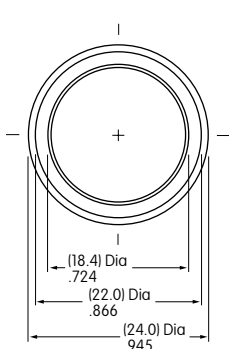

Single Pole

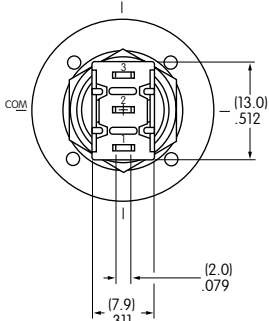

Double Pole

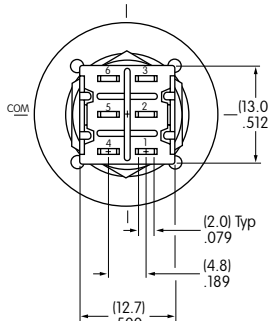

Effective Panel Thickness:
.217" (5.5mm) maximum

CUSTOM ASSEMBLY WITH RECTANGULAR SHROUD



MB2011SB1W01-5C-A

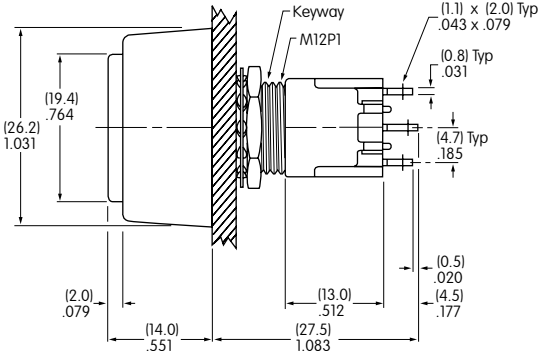
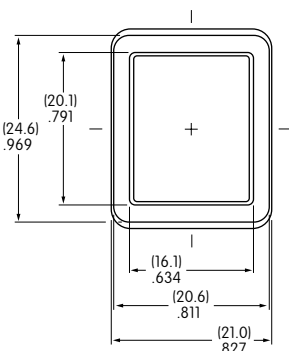

Single Pole

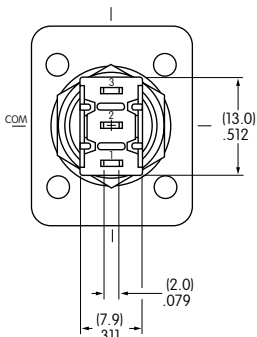

Double Pole

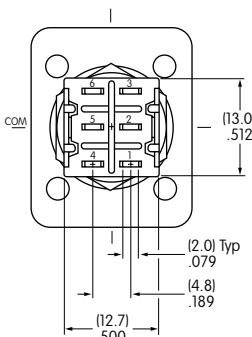

Effective Panel Thickness:
.217" (5.5mm) maximum

General Specifications

Electrical Capacity (Resistive Load)

Power Level (silver):	3A @ 125V AC
Logic Level (gold):	0.4VA maximum @ 28V AC/DC maximum (Applicable Range 0.1mA ~ 0.1A @ 20mV ~ 28V)
Logic/Power Level:	Combines silver & gold ratings
(gold over silver)	Note: Find additional explanation of dual rating & operating range in Supplement section.

Other Ratings

Contact Resistance:	20 milliohms maximum for silver; 30 milliohms maximum for gold
Insulation Resistance:	1,000 megohms minimum @ 500V DC
Dielectric Strength:	1,000V AC minimum between contacts for 1 minute minimum; 1,500V AC minimum between contacts & case for 1 minute minimum
Mechanical Life:	200,000 operations minimum
Electrical Life:	25,000 operations minimum for silver; 100,000 operations minimum for gold
Nominal Operating Force:	Single pole 2.45N; double pole 3.92N
Travel	Pretravel .024" (0.6mm); Overtravel .016" (0.4mm); Total Travel .039" (1.0mm)

Materials & Finishes

Plunger:	Brass with nickel plating
Bushing:	Brass with nickel plating
Frame:	Stainless steel
Case:	Polybutylene terephthalate (PBT) (UL94V-0)
Base:	Diallyl phthalate resin (UL94V-0)
Movable Contactor:	Phosphor bronze with silver or gold plating
Movable Contacts:	Silver alloy (code W); copper with gold plating (code G); or silver alloy with gold plating (code A)
Stationary Contacts:	Silver alloy with silver plating (code W); copper or brass with gold plating (code G); or silver with gold plating (code A)
Terminals:	Copper or brass with silver plating; copper or brass with gold plating

Environmental Data

Operating Temp Range:	-30°C through +85°C (-22°F through +185°F)
Humidity:	90 ~ 95% humidity for 96 hours @ 40°C (104°F)
Vibration:	10 ~ 55Hz with peak-to-peak amplitude of 1.5mm traversing the frequency range & returning in 1 minute; 3 right angled directions for 2 hours
Shock:	50G (490m/s ²) acceleration (tested in 6 right angled directions, with 3 shocks in each direction)

Installation

Mounting Torque:	1.5Nm (13.0 lb•in) for double nut; 0.7Nm (6.0 lb•in) for single nut
Cap Installation Force:	80.0N (18.0 lbf) maximum downward force on actuator
Soldering:	Wave Soldering (PC version): See Profile B in Supplement section. Manual Soldering: See Profile B in Supplement section.
Cleaning:	These devices are not process sealed. Hand clean locally using alcohol based solution. See Cleaning Specifications in Supplement section.

Standards & Certifications

Flammability Standards:	UL94V-0 case & base
UL:	File No. E44145 - Recognized only when ordered with marking on switch. Add "/U" or "/CUL" before dash in part number to order UL recognized switch. All single and double pole models recognized at 3A @ 125V AC or 0.4VA max. @ 28V DC max.
CSA:	File No. 023535_0_000 - Certified only when ordered with marking on switch. Add "/C" before dash in part number to order CSA certified switch. Single pole models with PC, solder lug, or Wirewrap terminals & double pole with PC or Wirewrap terminals certified at 3A @ 125V AC or 0.4VA @ 28V maximum.

Distinctive Characteristics

Snap-acting mechanism gives smooth actuation, short stroke, light touch, and audible feedback. This mechanism also provides long mechanical life.

High torque bushing construction prevents rotation or separation from frame during installation.

Antijamming design protects contacts from damage due to excessive downward force on the actuator.

Compatible companions with M series toggles. Body, bushing, and footprint dimensions ideal for mounting MB2400 pushbuttons and M toggles next to one another.

Stainless steel frame resists corrosion.

Longer center solder lug terminal simplifies wiring and soldering.

Silver contacts of specially composed alloy for hardness.

Epoxy sealed terminals prevent entry of solder flux and other contaminants.

Prominent external insulating barriers increase insulation resistance and dielectric strength.

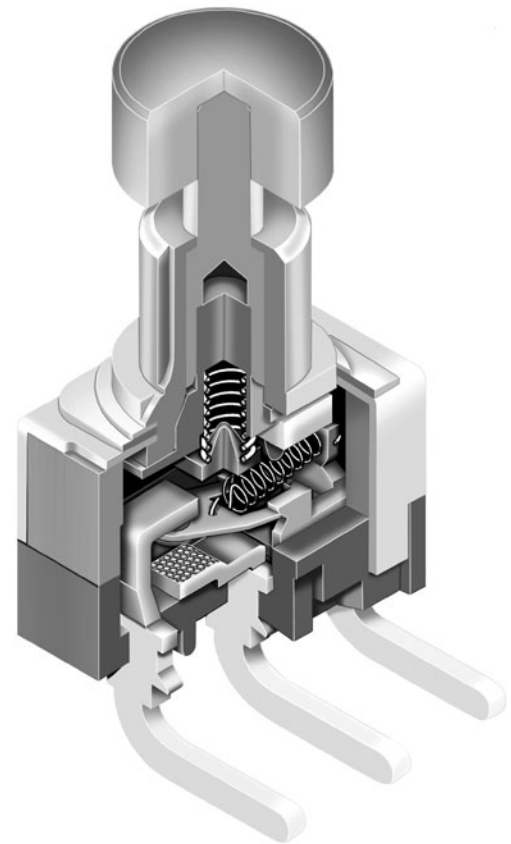

Actual Size

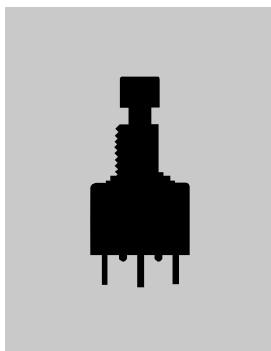

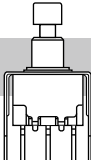
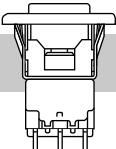
	Bushing Mount	Page C98
	Bracket PC Mount	Page C102
	Snap-in Mount	Page C108

- Toggle
- Rockers
- Pushbuttons**
- Illuminated PB
- Programmable
- Keylocks
- Rotaries
- Slides
- Tactiles
- Tilt
- Touch
- Indicators
- Accessories
- Supplement

TYPICAL SWITCH ORDERING EXAMPLE

MB24

11

E1

W

01

F

A

Poles & Circuits

11	SPDT	ON	(ON)
61	DPDT	ON	(ON)
() = Momentary			

Contact Materials & Ratings

W	Silver Rated 3A @ 125V AC
G	Gold Rated 0.4VA max @ 28V AC/DC max
A	Gold over Silver Rated 3A @ 125V AC & 0.4VA max @ 28V AC/DC max

Caps

F	.201" (5.1mm) Diameter
H	.295" (7.5mm) Diameter

Bushings

E1	.285" (7.24mm) Threaded with D Flat
E2	.285" (7.24mm) Smooth with D Flat
A1	.280" (7.1mm) Threaded with Keyway
A2	.280" (7.1mm) Smooth with Keyway
S1	.350" (8.9mm) Threaded with Keyway
S2	.350" (8.9mm) Smooth with Keyway

Terminals

01	Solder Lug*
03	.250" (6.35mm) Straight PC
05	.425" (10.8mm) Wirewrap
06	.750" (19.05mm) Wirewrap
07	.964" (24.5mm) Wirewrap

Cap Colors

A	Black
B	White
C	Red

* Wire harness & cable assemblies offered only in Americas

IMPORTANT:



Switches are supplied without UL, cULus & CSA marking unless specified. **UL, cULus & CSA recognized only when ordered with marking on the switch.** Specific models, ratings, & ordering instructions are noted on General Specifications page.

DESCRIPTION FOR TYPICAL ORDERING EXAMPLE

MB2411E1W01-FA

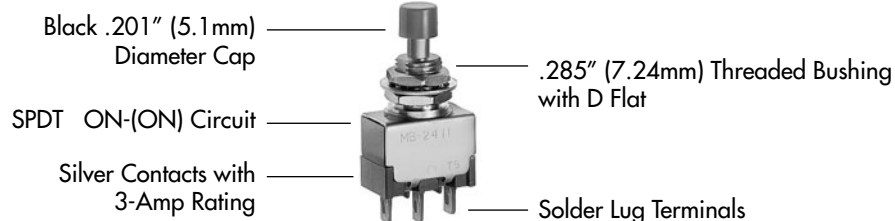

Toggles
Rockers
Pushbuttons
Illuminated PB
Programmable
Keylocks
Rotaries
Slides
Tactiles
Tilt
Touch
Indicators
Accessories
Supplement

POLES & CIRCUITS

Pole	Model	Plunger Position () = Momentary		Connected Terminals		Throw & Switch Schematics
		Normal	Down	Normal	Down	
						Note: Terminal numbers are not actually on the switch.
SP	MB2411	ON	(ON)	1-3	1-2	SPDT
DP	MB2461	ON	(ON)	1-3 4-6	1-2 4-5	DPDT

BUSHINGS

Note: Plunger selection is not required for MB2400 pushbuttons. The plunger can be used with or without a cap.

E1 .285" (7.24mm)
Threaded with D Flat

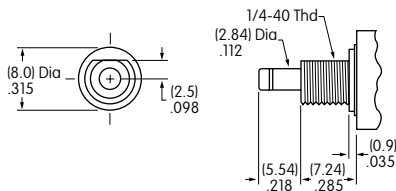

Maximum Panel Thickness with Standard Hardware: .068" (1.74mm)

A1 .280" (7.1mm)
Threaded with Keyway

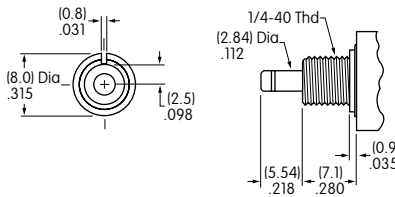

Maximum Panel Thickness with Standard Hardware: .068" (1.74mm)

S1 .350" (8.9mm)
Threaded with Keyway

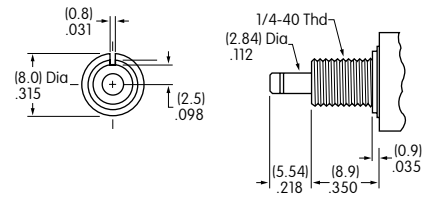

Maximum Panel Thickness with Standard Hardware: .134" (3.40mm)

E2 .285" (7.24mm)
Smooth with D Flat

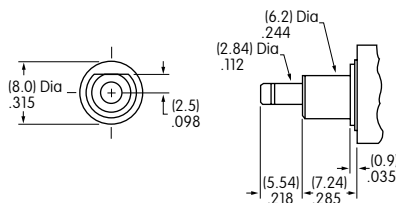

A2 .280" (7.1mm)
Smooth with Keyway

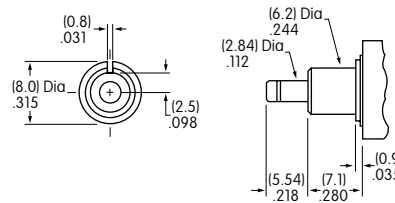

S2 .350" (8.9mm)
Smooth with Keyway

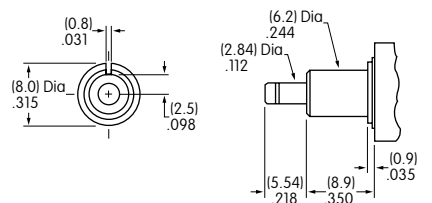

Panel Cutouts

For A1, A2, S1, or S2 Bushing with Keyway

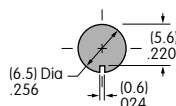

For E1 or E2 Bushing with D Flat

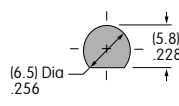

With Optional Locking Ring

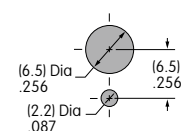

Standard hardware includes 2 hex nuts & 1 lockwasher.
Hardware is illustrated following the Typical Switch Dimension drawings.

CONTACT MATERIALS & RATINGS

W

Silver over Silver

Power Level

3A @ 125V AC

G

Gold over Brass or Copper

Logic Level

0.4VA maximum @ 28V AC/DC maximum

Note: Complete explanation of operating range in Supplement section.

A

Gold over Silver

Power Level
or Logic Level

3A @ 125V AC
or 0.4VA maximum @ 28V AC/DC maximum

Note: This dual rated option is suitable when two or more identical switches are used in logic and in power circuits within the same application. See Supplement section for complete explanation of dual rating and operating range.

TERMINALS

01

Solder Lug

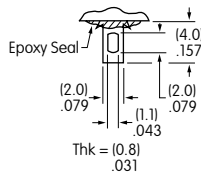

03

.250" (6.35mm)
Straight PC

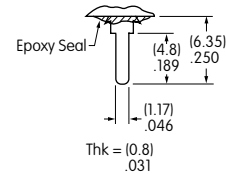

Wirewrap or Extended PC

05

.425"
(10.8mm)

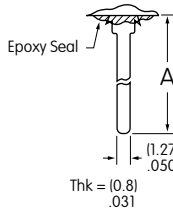

Refer to footprints if using
as extended PC terminal.

Dimension A = terminal
lengths as shown beside
the code boxes at left.

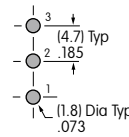

Single Pole

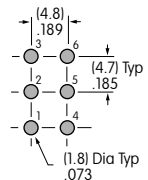

Double Pole

06

.750"
(19.05mm)

07

.964"
(24.5mm)

CAPS & CAP COLORS

F

AT475
.201" (5.1mm)
Diameter Cap

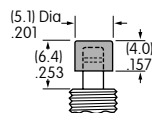

Material: Polyamide

Finish: Glossy



H

AT496
.295" (7.5mm)
Diameter Cap

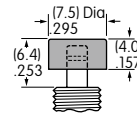

Material: Polyamide

Finish: Glossy



Cap Colors
Available:

A Black

B White

C Red

TYPICAL SWITCH DIMENSIONS

Single Pole

Solder Lug

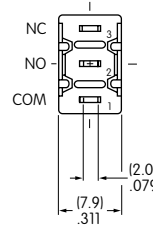
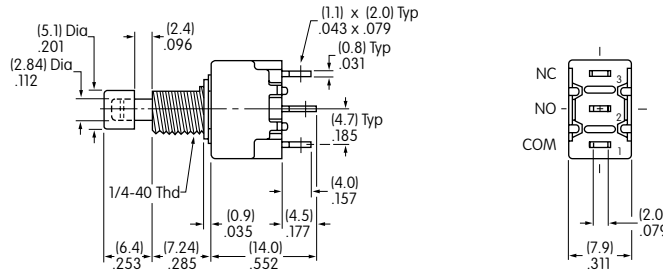
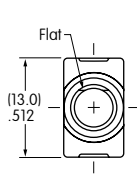

MB2411E1W01-FA

Double Pole

Solder Lug

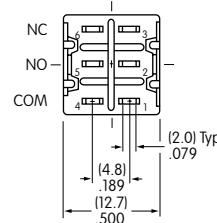
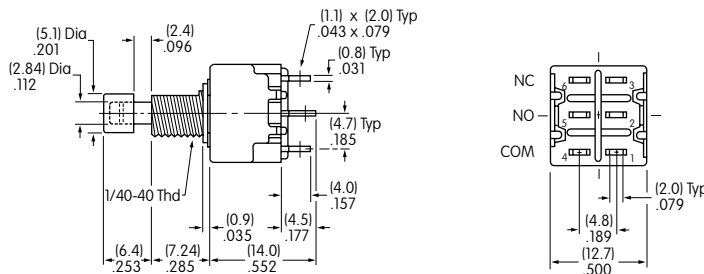
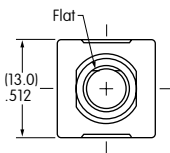

MB2461E1W01-FA

HARDWARE

Standard Hardware

AT513H Inch Threaded Hexagon Nut

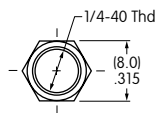

2 included with each switch

Material:
Brass with Nickel Plating

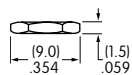

AT509 Lockwasher

1 included with each switch

Material:
Steel with Zinc/Chromate

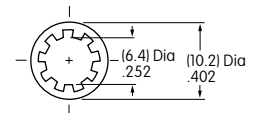

AT507H Locking Ring for A1 or S1 Bushing

Material:
Steel with Zinc/Chromate

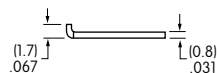
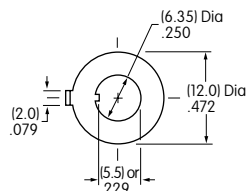

AT515 Locking Ring for E1 Bushing

Material:
Steel with Zinc/Chromate

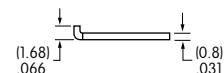
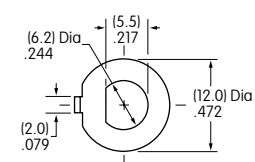

TYPICAL SWITCH ORDERING EXAMPLE

MB24

11

A2

G

40

F

A

Poles & Circuits

11	SPDT	ON	(ON)
61	DPDT	ON	(ON)

() = Momentary

Contact Materials & Ratings

W	Silver Rated 3A @ 125V AC
G	Gold Rated 0.4VA max @ 28V AC/DC max
A	Gold over Silver Rated 3A @ 125V AC & 0.4VA max @ 28V AC/DC max

Caps

F	.201" (5.1mm) Dia.
H	.295" (7.5mm) Dia.

Cap Colors

A	Black
B	White
C	Red

Bushings

A2	.280" (7.1mm) Smooth with Keyway
A1	.280" (7.1mm) Threaded with Keyway
E2	.285" (7.24mm) Smooth with D Flat
E1	.285" (7.24mm) Threaded with D Flat
S2	.350" (8.9mm) Smooth with Keyway
S1	.350" (8.9mm) Threaded with Keyway

Terminals

With Bracket

13	.250" (6.35mm) Straight PC with .465" (11.8mm) Bracket
15	.425" (10.8mm) Straight PC with .630" (16.0mm) Bracket
17	.964" (24.5mm) Straight PC with 1.150" (29.2mm) Bracket

With Reinforced Bracket

23	.250" (6.35mm) Straight PC with .465" (11.8mm) Bracket
25	.425" (10.8mm) Straight PC with .630" (16.0mm) Bracket
26	.750" (19.05mm) Straight PC with .953" (24.2mm) Bracket

With Terminal Support

30	Right Angle PC
40	Vertical PC

IMPORTANT:



Switches are supplied without UL, cULus & CSA marking unless specified. **UL, cULus & CSA recognized only when ordered with marking on the switch.**

Specific models, ratings, & ordering instructions are noted on General Specifications page.

DESCRIPTION FOR TYPICAL ORDERING EXAMPLE

MB2411A2G40-FA

.280" (7.1mm) Smooth Bushing with Keyway
Black .201" (5.1mm) Diameter Cap

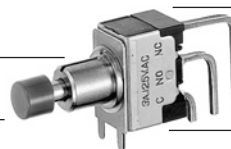

SPDT ON-(ON) Circuit
Vertical PC Terminals
Gold Contacts with 0.4VA Rating

POLES & CIRCUITS

Pole	Model	Plunger Position () = Momentary		Connected Terminals		Throw & Switch Schematics
		Normal	Down	Normal	Down	
						Note: Terminal numbers are not actually on the switch. * When using terminal code 32, connected terminals and schematic are reversed.
SP	*MB2411	ON	(ON)	1-3	1-2	
DP	MB2461	ON	(ON)	1-3 4-6	1-2 4-5	

BUSHINGS

Note: Plunger selection is not required for MB2400 pushbuttons.
The plunger can be used with or without a cap.

A2 .280" (7.1mm)
Smooth with Keyway

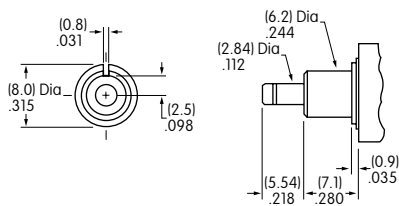

E2 .285" (7.24mm)
Smooth with D Flat

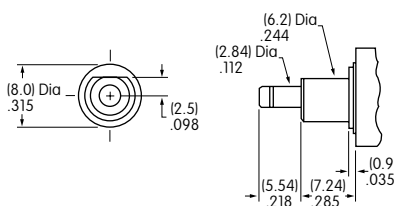

S2 .350" (8.9mm)
Smooth with Keyway

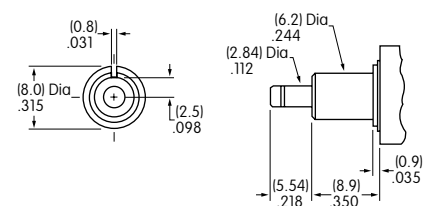

A1 .280" (7.1mm)
Threaded with Keyway

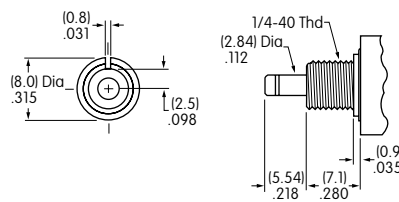

E1 .285" (7.24mm)
Threaded with D Flat

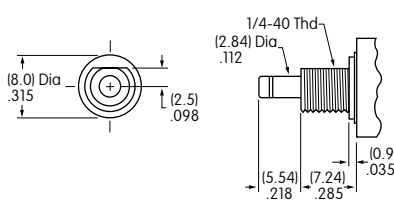

S1 .350" (8.9mm)
Threaded with Keyway

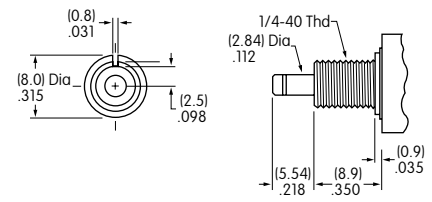

Maximum Panel Thickness with Standard Hardware: .068" (1.74mm)

Maximum Panel Thickness with Standard Hardware: .068" (1.74mm)

Maximum Panel Thickness with Standard Hardware: .134" (3.40mm)

Panel Cutouts

For A1, A2, S1, or S2 Bushing with Keyway

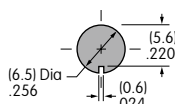

For E1 or E2 Bushing with D Flat

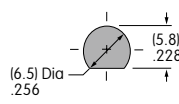

With Optional Locking Ring

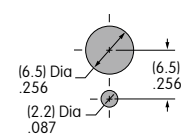

Standard hardware includes 2 hex nuts & 1 lockwasher.
Hardware is illustrated following the Typical Switch Dimension drawings.

Toggles
Rockers
Pushbuttons
Illuminated PB
Programmable
Keylocks
Rotaries
Slides
Tactiles
Tilt
Touch
Indicators
Accessories
Supplement

CONTACT MATERIALS & RATINGS

W

Silver over Silver

Power Level

3A @ 125V AC

G

Gold over Brass or Copper

Logic Level

0.4VA maximum @ 28V AC/DC maximum

Note: Complete explanation of operating range in Supplement section.

A

Gold over Silver

Power Level
or Logic Level

3A @ 125V AC
or 0.4VA maximum @ 28V AC/DC maximum

Note: This dual rated option is suitable when two or more identical switches are used in logic and in power circuits within the same application. See Supplement section for complete explanation of dual rating and operating range.

TERMINALS

Straight PC Mount with Bracket

13

.250" (6.35mm)
Terminal with
.465" (11.8mm)
Bracket

15

.425" (10.8mm)
Terminal with
.630" (16.0mm)
Bracket

17

.964" (24.5mm)
Terminal with
1.150" (29.2mm)
Bracket

23

.250" (6.35mm)
Terminal with
.465" (11.8mm)
Bracket

25

.425" (10.8mm)
Terminal with
.630" (16.0mm)
Bracket

26

.750" (19.05mm)
Terminal with
.953" (24.2mm)
Bracket

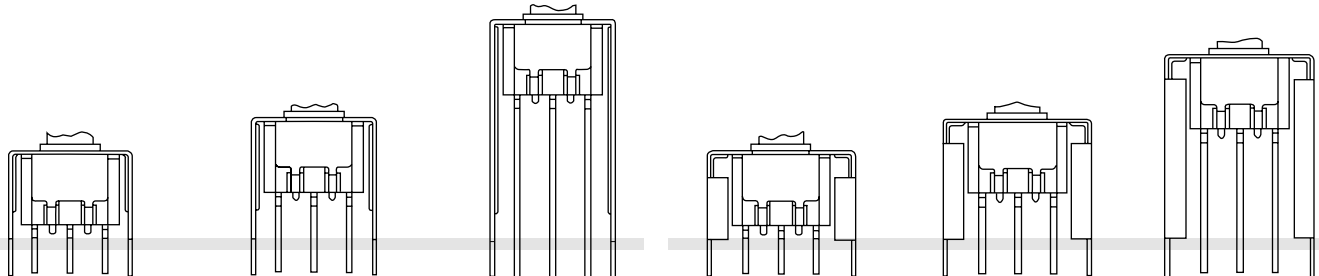

30

Right Angle PC

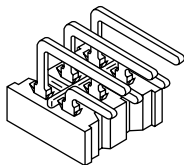

32

Right Angle PCB with Reverse Circuit
Available only in single pole with
0.4VA rating (code G)

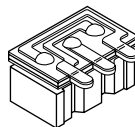

40

Vertical PC

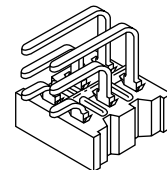

PCB footprints are on the following Typical Switch Dimension pages.

CAPS & CAP COLORS

F

AT475
.201" (5.1mm)
Diameter Cap

Material: Polyamide

Finish: Glossy

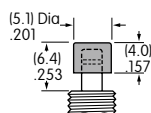

H

AT496
.295" (7.5mm)
Diameter Cap

Material: Polyamide

Finish: Glossy

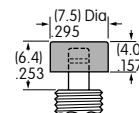

Cap Colors
Available:

A Black

B White

C Red

TYPICAL SWITCH DIMENSIONS

Straight PC • Bracket

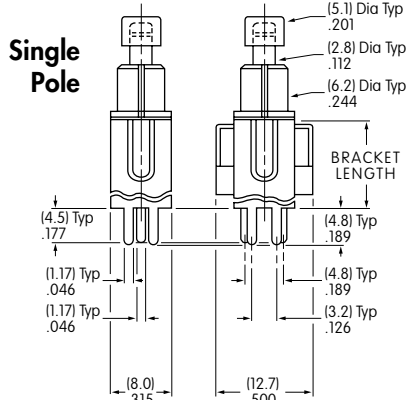
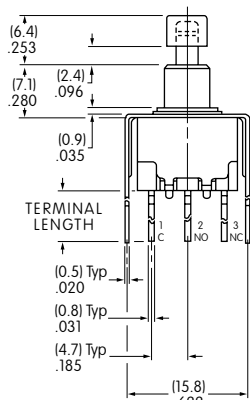

Double Pole



MB2411A2G13-FA

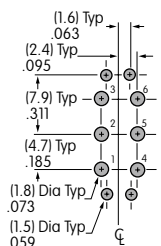
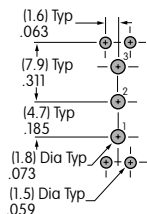

Terminal Code:	Terminal Length:	Bracket Length:
13	.250 (6.35mm)	.465 (11.8mm)
15	.425 (10.8mm)	.630 (16.0mm)
17	.964 (24.5mm)	1.150 (29.2mm)

Straight PC • Reinforced Bracket

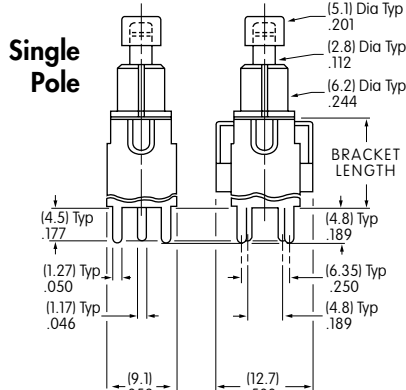
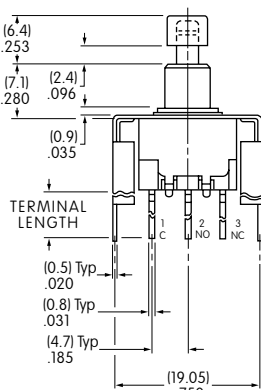

Double Pole



MB2411A2G23-FA

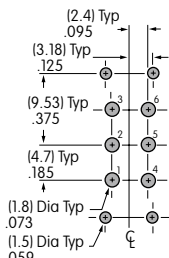
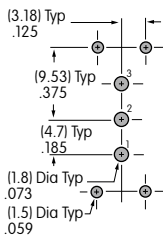

Terminal Code:	Terminal Length:	Bracket Length:
23	.250 (6.35mm)	.465 (11.8mm)
25	.425 (10.8mm)	.630 (16.0mm)
26	.750 (19.05mm)	.953 (24.2mm)

TYPICAL SWITCH DIMENSIONS

Right Angle PC

Single Pole

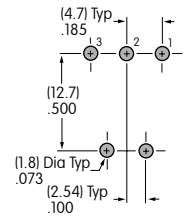
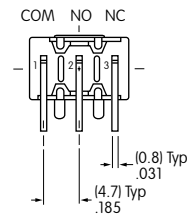
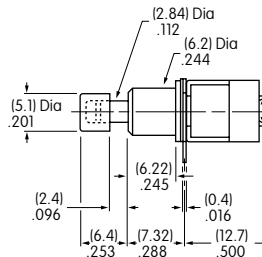
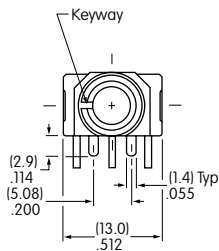

MB2411A2G30-FA

Right Angle PC

Double Pole

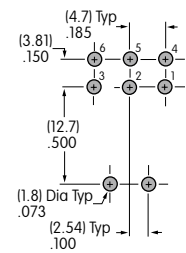
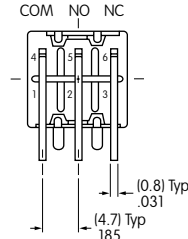
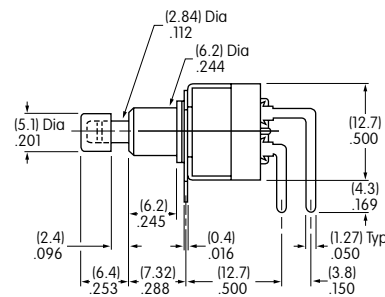
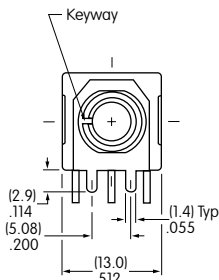

MB2461A2G30-FA

Right Angle PCB

Single Pole • Reverse Circuit

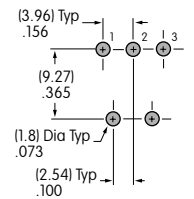
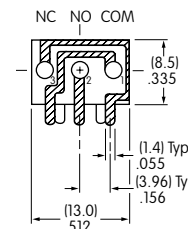
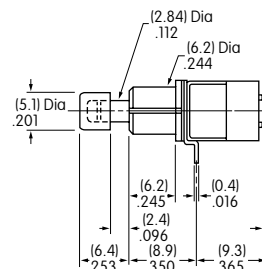
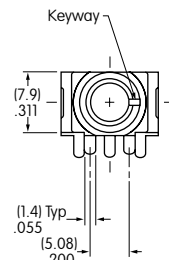

MB2411A2G32-FA

Vertical PC

Single Pole

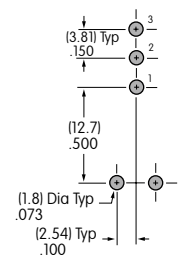
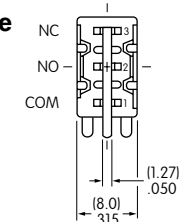
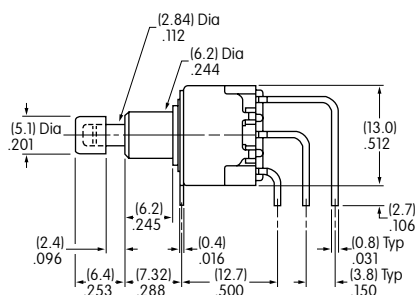
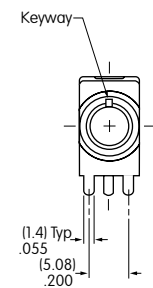

Double Pole

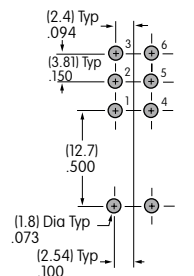
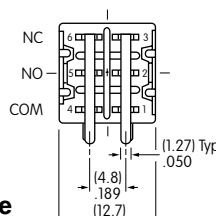

MB2411A2G40-FA

Toggles

Rockers

Pushbuttons

Illuminated PB

Programmable

Keylocks

Rotaries

Slides

Tactiles

Tilt

Touch

Indicators

Accessories

Supplement

HARDWARE

Standard Hardware

AT513H Inch Threaded Hexagon Nut

2 included with each switch

Material:
Brass with Nickel Plating

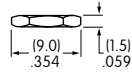
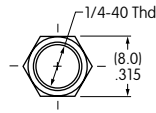

AT509 Lockwasher

1 included with each switch

Material:
Steel with Zinc/Chromate

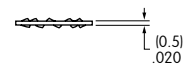
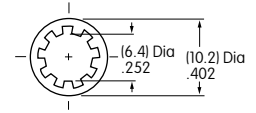

Optional Hardware

AT507H Locking Ring for A1 or S1 Bushing

Material:
Steel with Zinc/Chromate

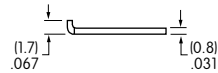
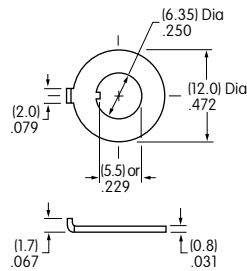

AT515 Locking Ring for E1 Bushing

Material:
Steel with Zinc/Chromate

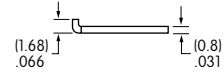
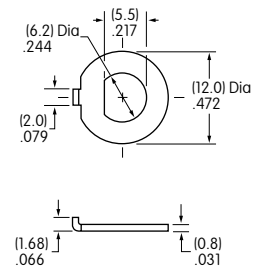

Toggles

Rockers

C Pushbuttons

Illuminated PB

Programmable

Keylocks

Rotaries

Slides

Tactiles

Tilt

Touch

Indicators

Accessories

Supplement

TYPICAL SWITCH ORDERING EXAMPLE

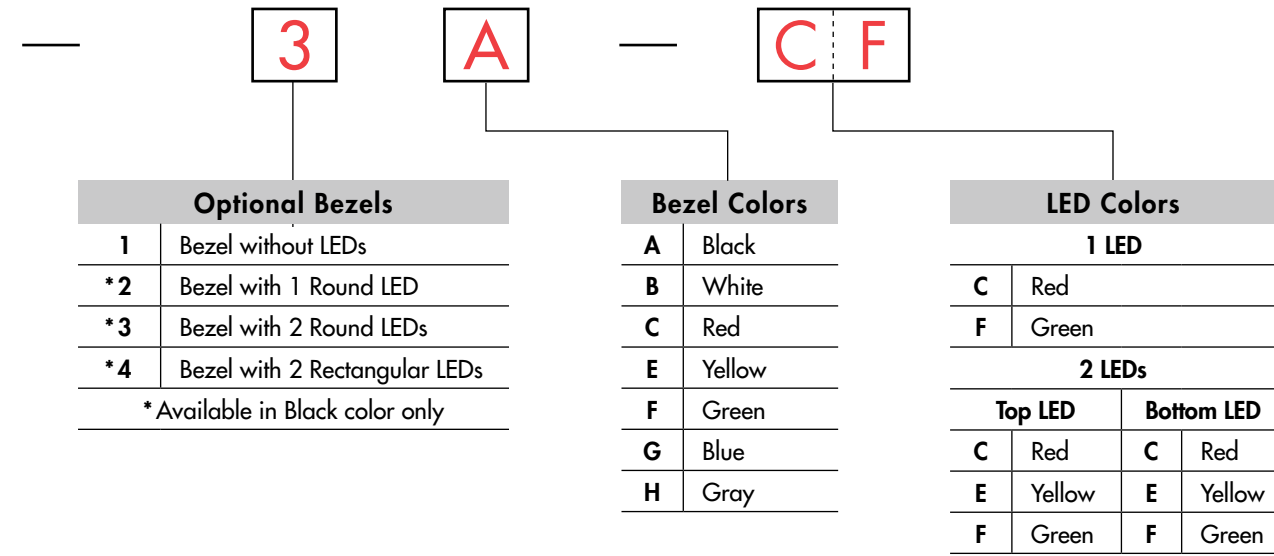
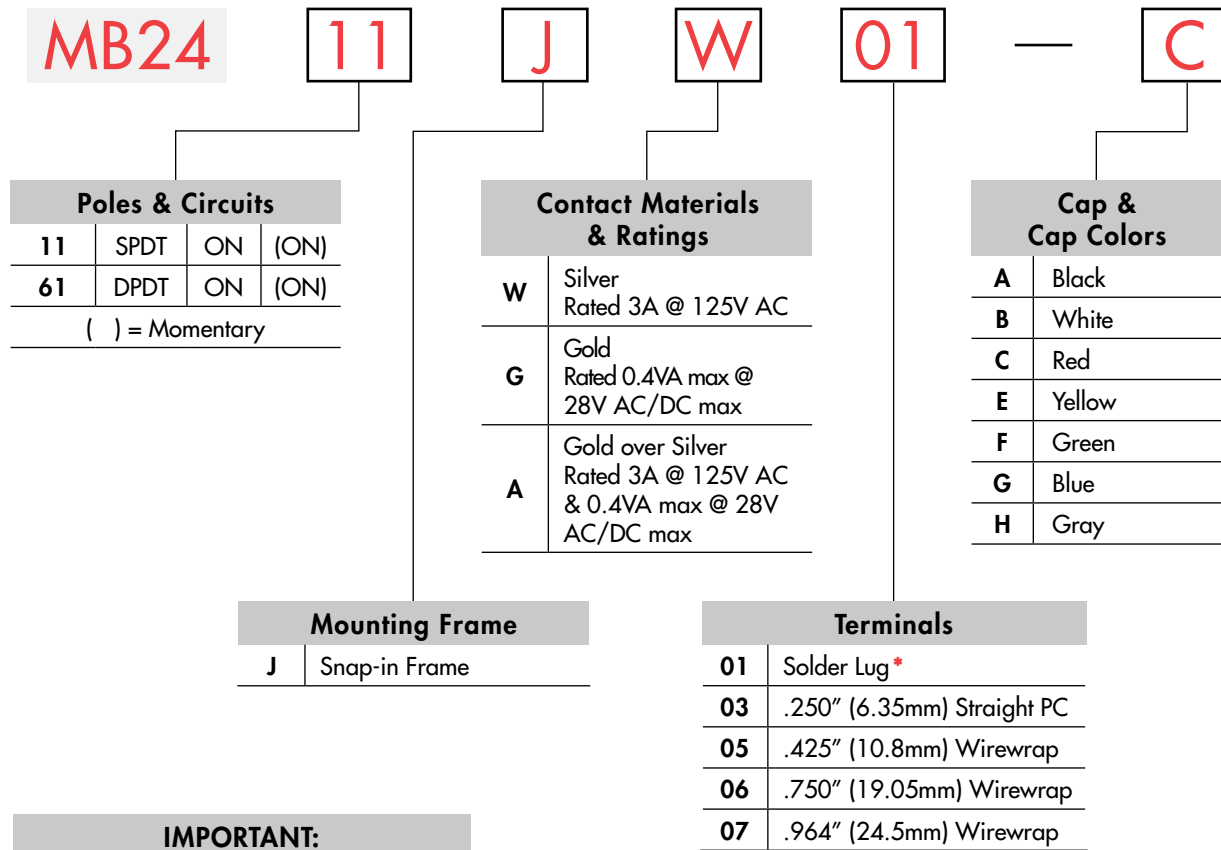

IMPORTANT:



Switches are supplied without UL, cULus & CSA marking unless specified. **UL, cULus & CSA recognized only when ordered with marking on the switch.** Specific models, ratings, & ordering instructions are noted on General Specifications page.

* Wire harness & cable assemblies offered only in Americas

DESCRIPTION FOR TYPICAL ORDERING EXAMPLE

MB2411JW01-C

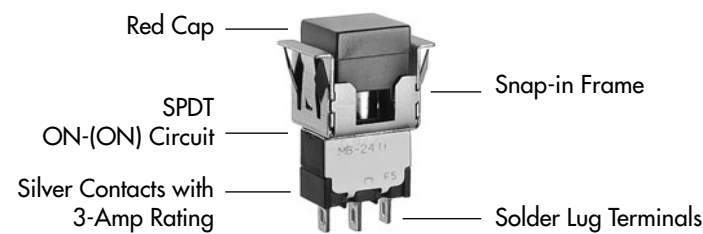

DESCRIPTION FOR TYPICAL ORDERING EXAMPLE

MB2411JW01-C-3A-CF

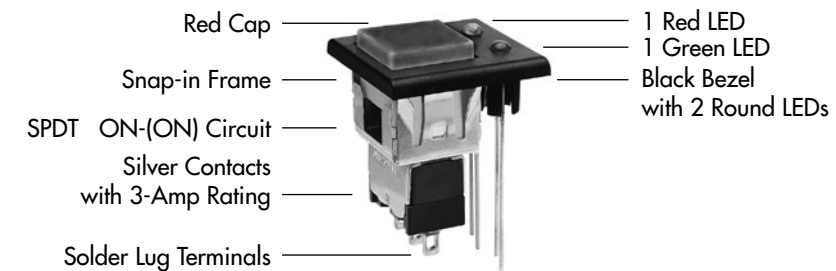

Toggles

Rockers

Pushbuttons

Illuminated PB

Programmable

Keylocks

Rotaries

Slides

Tactiles

Tilt

Touch

Indicators

Accessories

Supplement

POLES & CIRCUITS

Pole	Model	Plunger Position () = Momentary		Connected Terminals		Throw & Switch Schematics
		Normal	Down	Normal	Down	
SP	MB2411	ON	(ON)	1-3	1-2	SPDT
DP	MB2461	ON	(ON)	1-3 4-6	1-2 4-5	DPDT

Note: Terminal numbers are not actually on the switch.

MOUNTING FRAME

J

Snap-in Frame

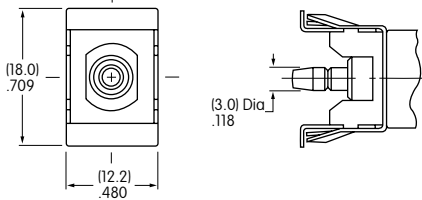

Panel Cutout for Single Pole without Bezel

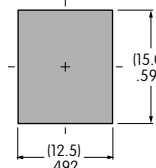

Panel Cutout for Double Pole without Bezel

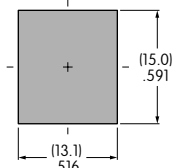

Panel Thickness without Bezel: .039" ~ .157" (1.0mm ~ 4.0mm)
 Panel Thickness with Bezel: .039" ~ .126" (1.0mm ~ 3.2mm)

CONTACT MATERIALS & RATINGS

W

Silver over Silver

Power Level

3A @ 125V AC

G

Gold over Brass or Copper

Logic Level

0.4VA maximum @ 28V AC/DC maximum

Note: Complete explanation of operating range in Supplement section.

A

Gold over Silver

Power Level
or Logic Level

3A @ 125V AC
or 0.4VA maximum @ 28V AC/DC maximum

Note: This dual rated option is suitable when two or more identical switches are used in logic and in power circuits within the same application. See Supplement section for complete explanation of dual rating and operating range.

TERMINALS

01

Solder Lug

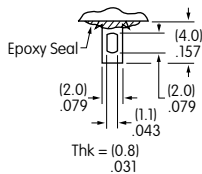

03

.250" (6.35mm)
Straight PC

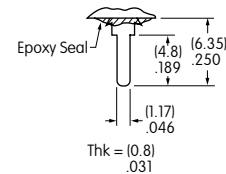

Wirewrap or Extended PC

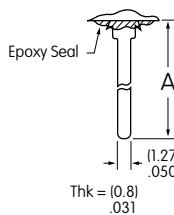

Refer to footprints if using as extended PC terminal.

Dimension A = terminal lengths as shown beside the code boxes at left.

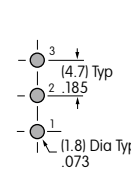

Single Pole

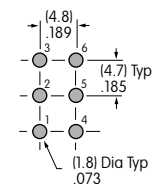

Double Pole

CAP & CAP COLORS

AT465 .453" (11.5mm) Square Cap

Material: Polycarbonate
Finish: Glossy

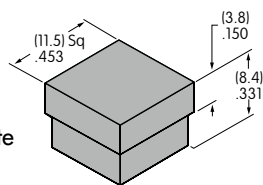

Contact factory for matte finish.

Legend details at end of this section.

A	Black	B	White	C	Red	E	Yellow
F	Green	G	Blue	H	Gray		

OPTIONAL SNAP-IN BEZELS & BEZEL COLORS

1 AT207 Bezel

Material: Polycarbonate
Finish: Glossy

Contact factory for matte finish.

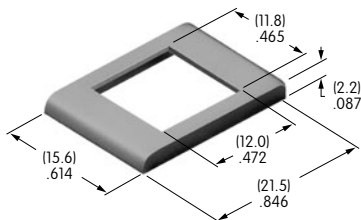

A	Black	F	Green
B	White	G	Blue
C	Red	H	Gray
E	Yellow		

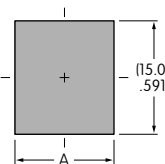

	Single Pole	Double Pole
A	(12.5)mm .492"	(13.1)mm .516"

2 AT208 Bezel for AT070 LED

Material: Polycarbonate
Finish: Glossy

Contact factory for matte finish.

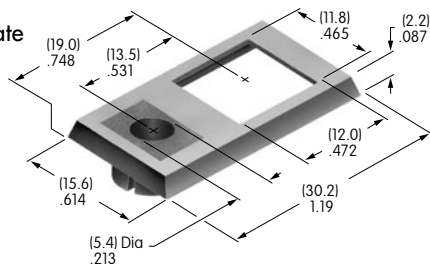

A Black
LED colors & specifications on next page.

	Single Pole	Double Pole
A	(12.5)mm .492"	(13.1)mm .516"
B	(6.25)mm .246"	(6.55)mm .258"

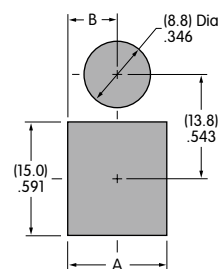

3 AT212 Bezel for AT617 LED

Material: Polycarbonate
Finish: Semi-glossy

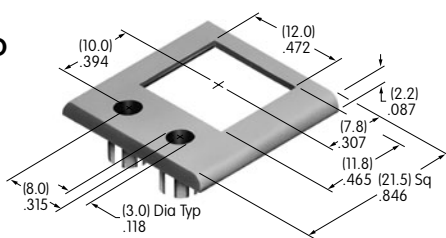

A Black
LED colors & specifications on next page.

	Single Pole	Double Pole
A	(18.4)mm .724"	(18.7)mm .736"

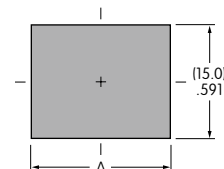

4 AT213 Bezel for AT618 LED

Material: Polycarbonate
Finish: Semi-glossy

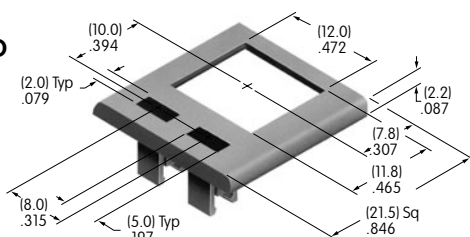

A Black
LED colors & specifications on next page.

	Single Pole	Double Pole
A	(18.4)mm .724"	(18.7)mm .736"

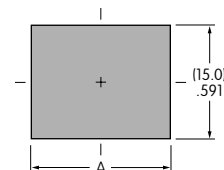

Bezel Assembly

1. Pry out tab on bezel to a 45° angle.

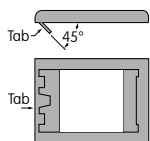

2. Insert switch frame under tab and snap on the bezel.

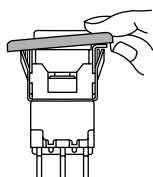

3. Push tab back into place.

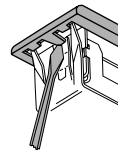

4. Snap assembled bezel and switch into panel.

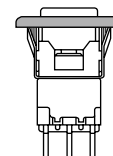

LED COLORS & SPECIFICATIONS

Bezel Orientation on Switch

AT070 LED
For Bezel AT208
with 1 LED

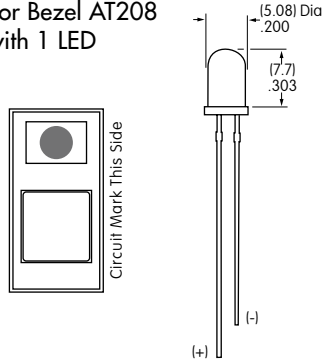

AT617 LED
For Bezel AT212
with 2 Round LEDs

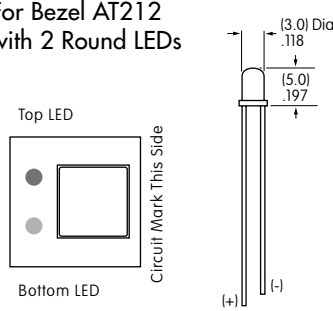

AT618 LED
For Bezel AT213
with 2 Rectangular LEDs

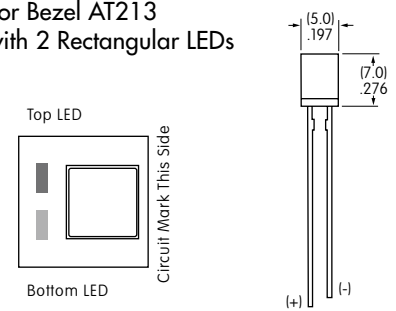

Note: Lead lengths may differ from manufacturing lot to lot. The longer lead is the anode (+).

		AT070		AT617			AT618		
		C	F	C	E	F	C	E	F
	Color	Red	Green	Red	Yellow	Green	Red	Yellow	Green
Forward Peak Current	I_{FM}	25mA	50mA	30mA	30mA	25mA	10mA	30mA	30mA
Typical Forward Current	I_F	20mA	30mA	20mA	20mA	20mA	8mA	24mA	24mA
Forward Voltage	V_F	2.8V	2.1V	2.0V	2.1V	2.2V	1.9V	2.0V	2.1V
Reverse Peak Voltage	V_{RM}	4V	5V	5V	5V	5V	5V	5V	5V
Current Reduction Rate Above 25°C	ΔI_F	0.33 mA/°C	0.40 mA/°C	0.40 mA/°C	0.40 mA/°C	0.33 mA/°C	0.13 mA/°C	0.40 mA/°C	0.40 mA/°C
Ambient Temperature Range (when used with a bezel)		-10° ~ +70°C		-15° ~ +70°C			-15° ~ +70°C		

The electrical specifications shown are determined at a basic temperature of 25°C.
LED circuit is independent of switch operation. LED is colored in OFF state.

If the source voltage is greater than the rated voltage of the LED, a ballast resistor must be connected in series with the LED.
The ballast resistor calculation and more lamp detail are shown in the Supplement section.

TYPICAL SWITCH DIMENSIONS

Solder Lug

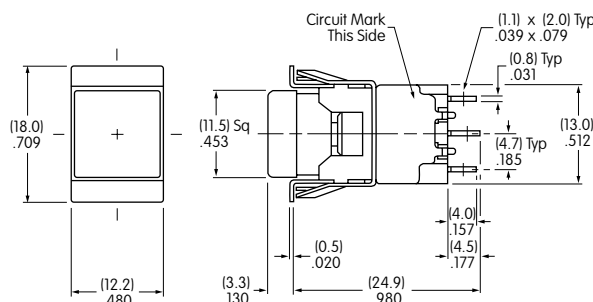

Single Pole

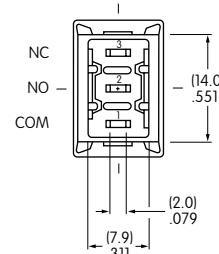

Double Pole

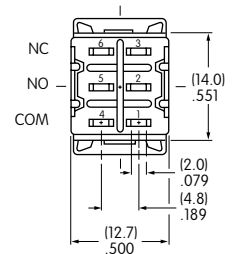

MB2411JW01-C

TYPICAL SWITCH DIMENSIONS

Single & Double Pole

Solder Lug • AT207 Bezel

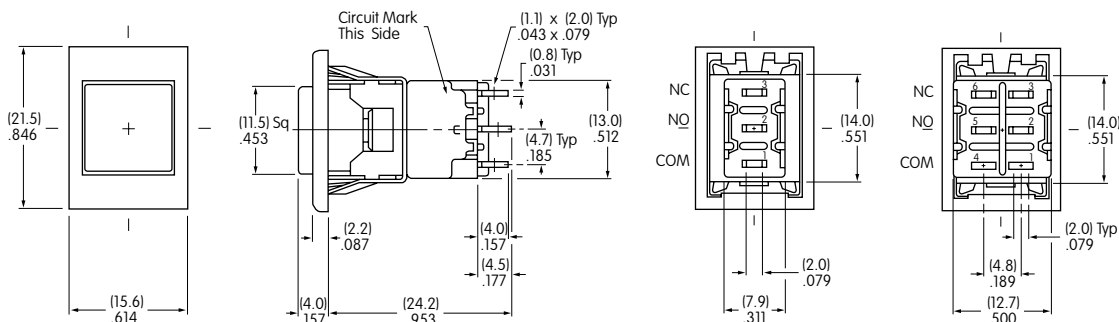

MB2411JW01-C-1A

Single Pole

Solder Lug • AT208 Bezel

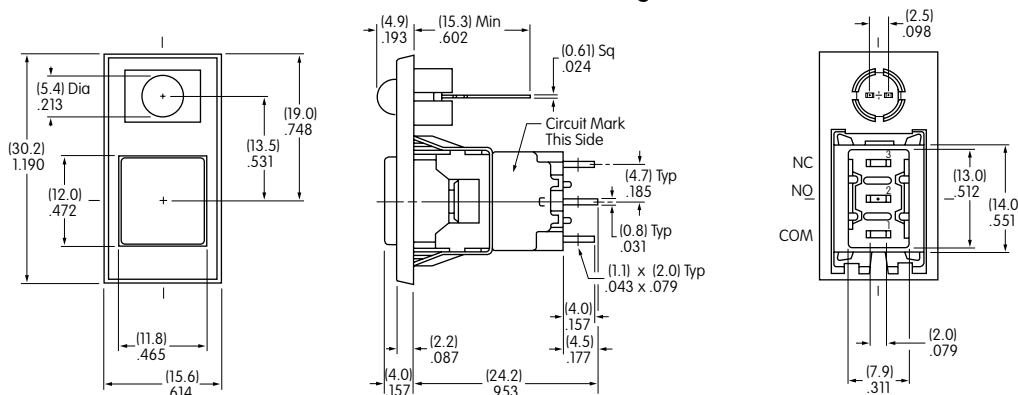

MB2411JW01-C-2A-C

Single Pole

Solder Lug • AT212 Bezel

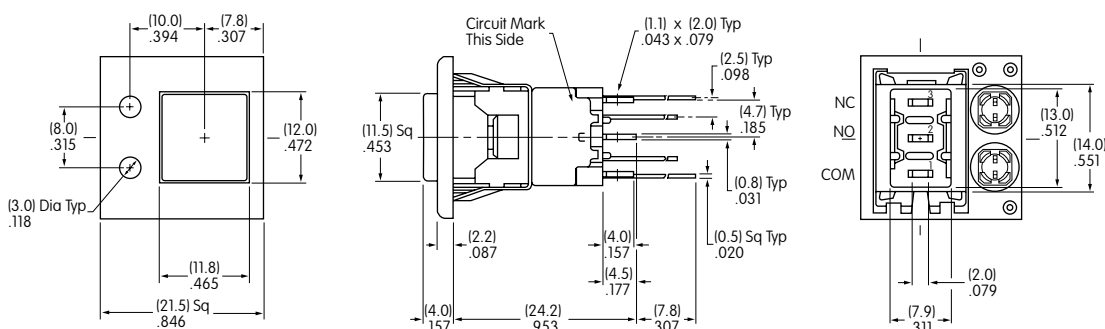

MB2411JW01-C-3A-CF

Double Pole

Solder Lug • AT213 Bezel

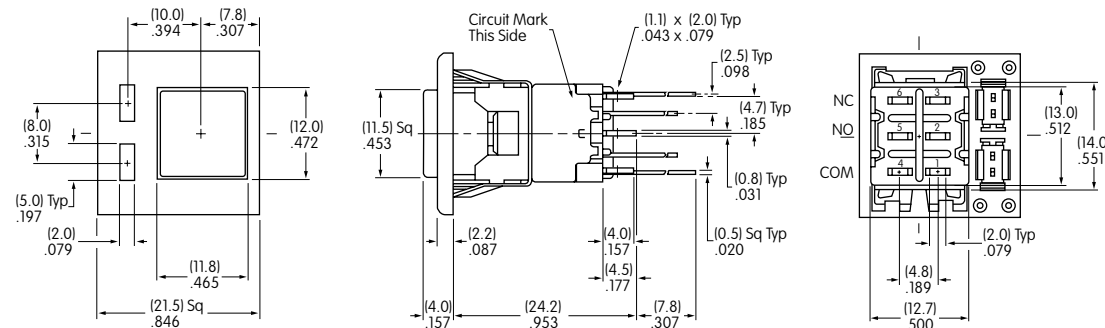

MB2461JW01-C-4A-CF

LEGENDS

NKK Switches can provide custom legends for caps. Contact factory for more information.

Suggested Printable Area for Cap

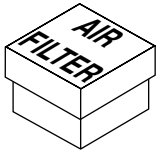
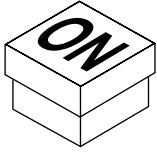

Recommended Print Method:

Screen Print or Pad Print

Epoxy based ink is recommended.

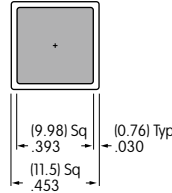

AT465

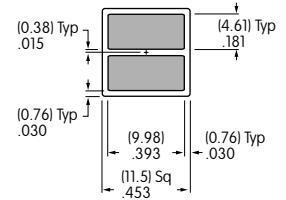

AT465

Shaded areas are printable areas.

General Specifications

Electrical Capacity (Resistive Load)

Power Level (code W):	3A @ 125V AC
Logic Level (code G):	0.4VA maximum @ 28V AC/DC maximum (Applicable Range 0.1mA ~ 0.1A @ 20mV ~ 28V)
Logic/Power Level (code A):	Combines W & G ratings Note: See Supplement section to find explanation of operating range.

Other Ratings

Contact Resistance:	20 milliohms maximum for silver; 30 milliohms maximum for gold
Insulation Resistance:	1,000 megohms minimum @ 500V DC
Dielectric Strength:	1,000V AC minimum between contacts for 1 minute minimum; 1,500V AC minimum between contacts & case for 1 minute minimum
Mechanical Life:	200,000 operations minimum
Electrical Life:	25,000 operations minimum for silver; 100,000 operations minimum for gold
Nominal Operating Force:	Single pole 2.45N; double pole 3.92N
Travel:	Pretravel .024" (0.6mm); Overtravel .016" (0.4mm); Total Travel .039" (1.0mm)

Materials & Finishes

Plunger:	Brass with nickel plating
Bushing:	Brass with nickel plating
Mounting & Body Frames:	Stainless steel
Support Bracket:	Brass with tin plating
Case:	Glass fiber reinforced polyester (UL94V-0)
Base:	Diallyl phthalate resin
Movable Contactor:	Phosphor bronze with silver or gold plating
Movable Contacts:	Silver alloy (code W); copper with gold plating (code G)
Stationary Contacts:	Silver with silver plating (code W); copper or brass with gold plating (code G)
Terminals:	Copper with silver plating; copper or brass with gold plating

Environmental Data

Operating Temp Range:	-30°C through +85°C (-22°F through +185°F)
Humidity:	90 ~ 95% humidity for 100 hours @ 40°C (104°F)
Vibration:	10 ~ 55Hz with peak-to-peak amplitude of 1.5mm traversing the frequency range & returning in 1 minute; 3 right angled directions for 2 hours
Shock:	50G (490m/s ²) acceleration (tested in 6 right angled directions, with 5 shocks in each direction)

Installation

Mounting Torque:	1.5Nm (13 lb•in) for double nut; 0.7Nm (6 lb•in) for single nut
Cap Installation Force:	80N (18 lbf) maximum downward force on actuator

Processing

Soldering:	Wave Soldering Recommended: See Profile B in Supplement section. Manual Soldering: See Profile B in Supplement section.
Cleaning:	These devices are not process sealed. Hand clean locally using alcohol based solution.

Standards & Certifications

Flammability Standards:	UL94V-0 Case
UL :	File No. E44145 - Recognized only when ordered with marking on switch. Add "/U" or "/CUL" before dash in part number to order UL recognized switch. All single & double pole models recognized at 3A @ 125V AC or 0.4VA max. @ 28V AC/DC max.
CSA:	File No. 023535_0_000 - Certified only when ordered with marking on switch. Add "/C" before dash in part number to order CSA certified switch. Single pole & double pole models certified at 3A @ 125V AC or 0.4VA max. @ 28V AC/DC max.

Distinctive Characteristics

Short stroke and light touch.

Antijamming design protects contacts from damage due to excessive downward force on the actuator.

High torque bushing construction prevents rotation or separation from frame during installation.

Stainless steel frame resists corrosion.

Longer center solder lug terminal simplifies wiring and soldering.

Patented silver contacts of specially composed alloy for hardness.

Epoxy sealed terminals prevent entry of solder flux and other contaminants.

Snap-acting mechanism gives smooth actuation and audible feedback.

Prominent external insulating barriers increase insulation resistance and dielectric strength.

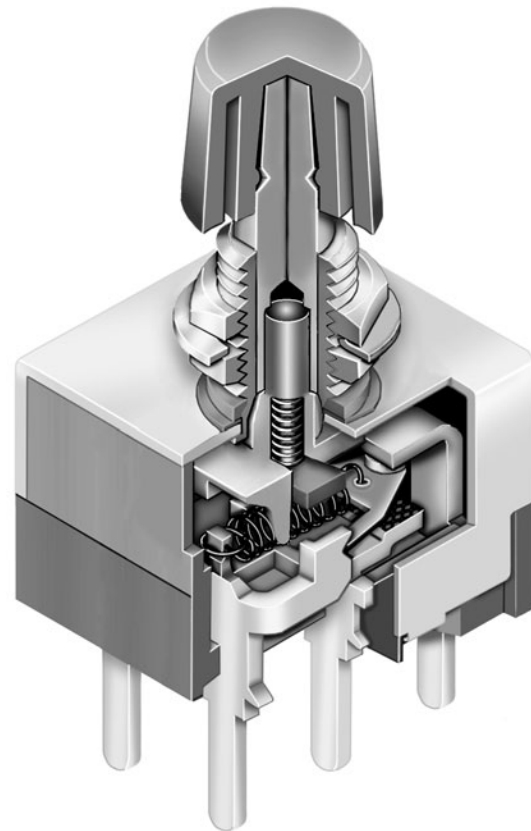

Actual Size

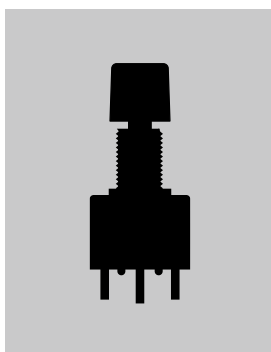

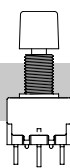
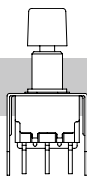
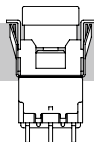
	Bushing Mount	Page C118
	Bracket PC Mount	Page C121
	Snap-in Mount	Page C124

- Toggle
- Rockers
- Pushbuttons**
- Illuminated PB
- Programmable
- Keylocks
- Rotaries
- Slides
- Tactiles
- Tilt
- Touch
- Indicators
- Accessories
- Supplement

TYPICAL SWITCH ORDERING EXAMPLE

MB25

11

S4

W

01

B

C

Poles & Circuits

11	SPDT	ON	(ON)
21	DPDT	ON	(ON)
() = Momentary			

Contact Materials & Ratings

W	Silver Rated 3A @ 125V AC
G	Gold Rated 0.4VA max @ 28V AC/DC max

Caps

B	.315" (8.0mm) Diameter
C	.394" (10.0mm) Diameter

Bushing

S4	.315" (8.0mm) Threaded with Keyway
-----------	---------------------------------------

Terminals

01	Solder Lug
03	.250" (6.35mm) Straight PC

Cap Colors

A	Black
B	White
C	Red
E	Yellow
F	Green
G	Blue

IMPORTANT:





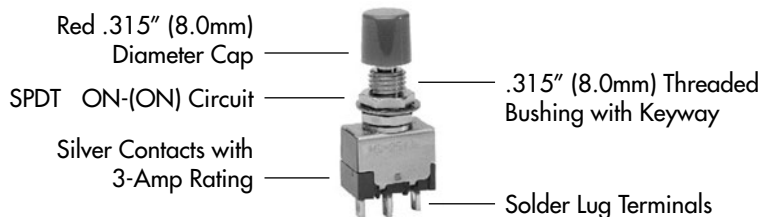

Switches are supplied without UL, cULus & CSA marking unless specified.
UL, cULus & CSA recognized only when ordered with marking on the switch.
 Specific models, ratings, & ordering instructions are noted on General Specifications page.

DESCRIPTION FOR TYPICAL ORDERING EXAMPLE

MB2511S4W01-BC

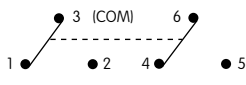

POLES & CIRCUITS

Pole	Model	Plunger Position () = Momentary		Connected Terminals		Throw & Switch Schematics
		Normal  Keyway	Down 	Normal  Keyway	Down 	
SP	MB2511	ON	(ON)	3-1	3-2	SPDT 
DP	MB2521	ON	(ON)	3-1 6-4	3-2 6-5	DPDT 

Note: Terminal numbers are not actually on the switch.

BUSHING

S4 .315" (8.0mm)
Threaded with Keyway

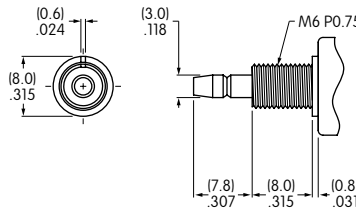

Panel Cutouts

Without Keyway

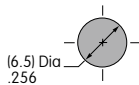

With Keyway

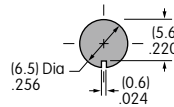

With Optional Locking Ring

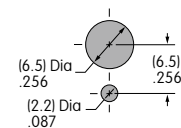

Maximum Panel Thickness with Standard Hardware: .134" (3.4mm)

Standard Hardware

AT513M Threaded
Hex Nut

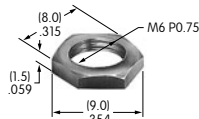

2 included
with each switch

Brass with
nickel plating

AT509
Lockwasher

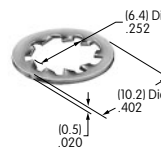

1 included
with each switch

Steel with
zinc/chromate

Optional Hardware

AT507M
Locking Ring

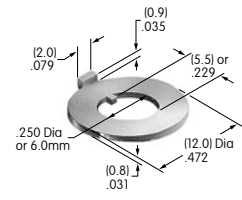

Steel with
zinc/chromate

CONTACT MATERIALS & RATINGS



Silver over Silver

Power Level

3A @ 125V AC



Gold over Brass or Copper

Logic Level

0.4VA maximum @ 28V AC/DC maximum

Note: Complete explanation of operating range in Supplement section.

TERMINALS

01 Solder Lug

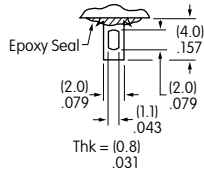

03 .250" (6.35mm) Straight PC

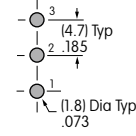
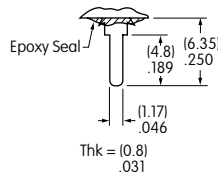

Single Pole

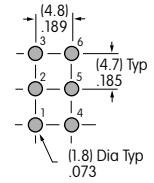

Double Pole

CAPS & CAP COLORS

B AT443
.315" (8.0mm) Diameter Cap

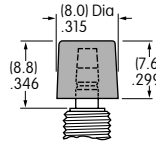

Material: Polycarbonate

Finish: Glossy

C AT442
.394" (10.0mm) Diameter Cap

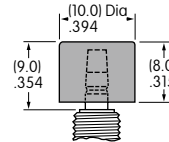

Material: Polycarbonate

Finish: Glossy

Cap Colors Available:



Black



White



Red



Yellow



Green



Blue

TYPICAL SWITCH DIMENSIONS

Solder Lug

Single Pole

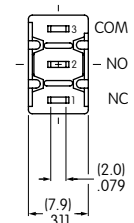
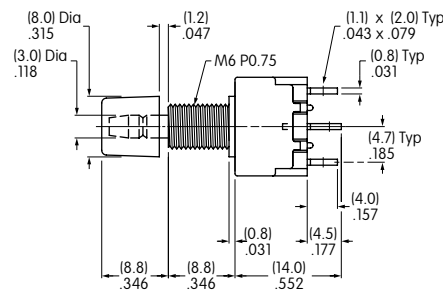
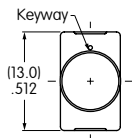

MB2511S4W01-BC

Solder Lug

Double Pole

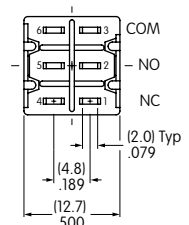
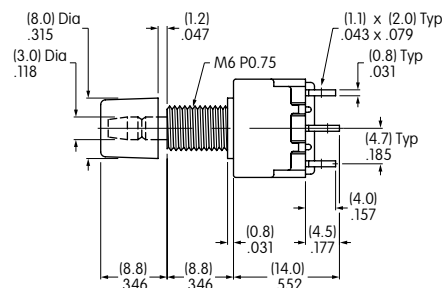
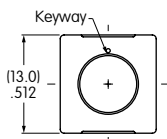

MB2521S4W01-BC

TYPICAL SWITCH ORDERING EXAMPLE

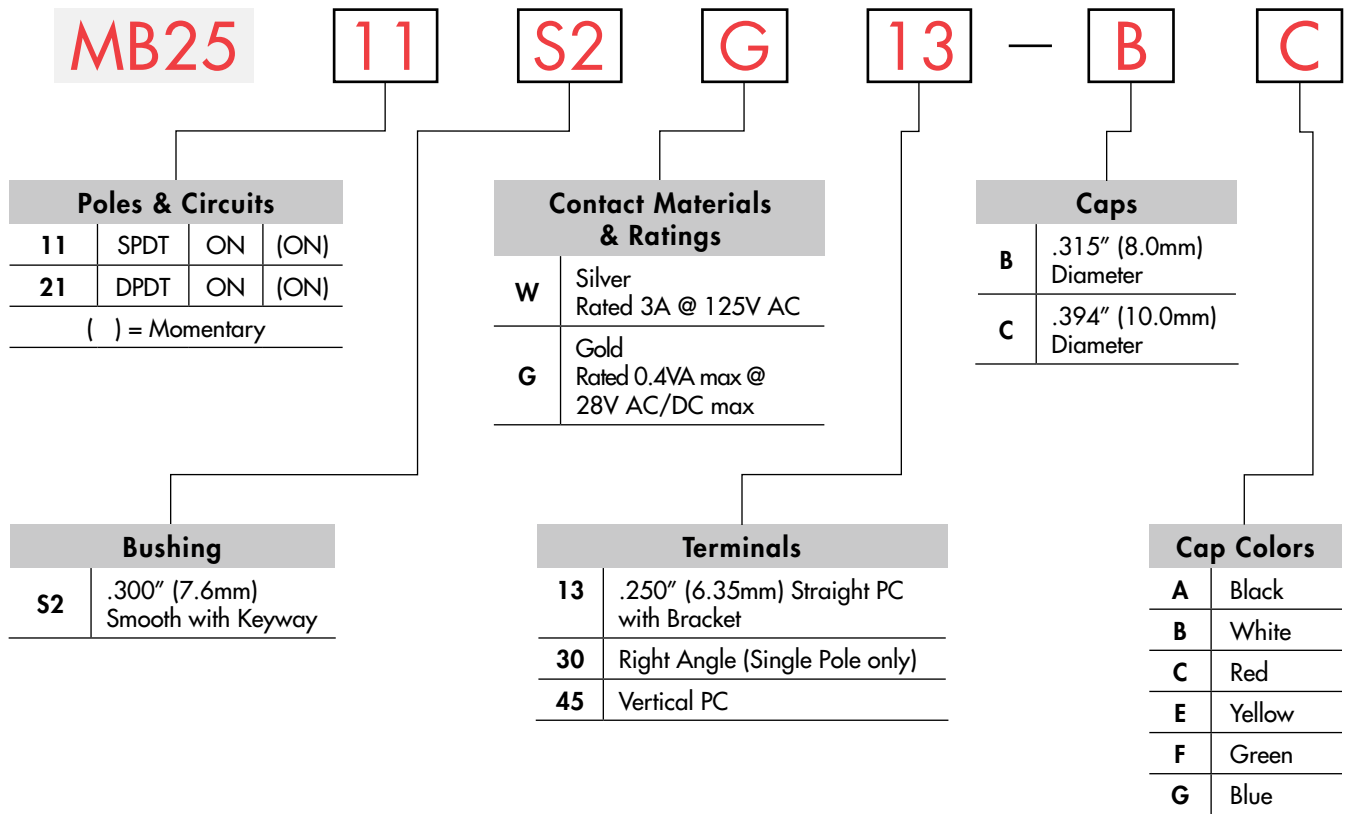

IMPORTANT:



Switches are supplied without UL, cULus & CSA marking unless specified. **UL, cULus & CSA recognized only when ordered with marking on the switch.** Specific models, ratings, & ordering instructions are noted on General Specifications page.

DESCRIPTION FOR TYPICAL ORDERING EXAMPLE

MB2511S2G13-BC

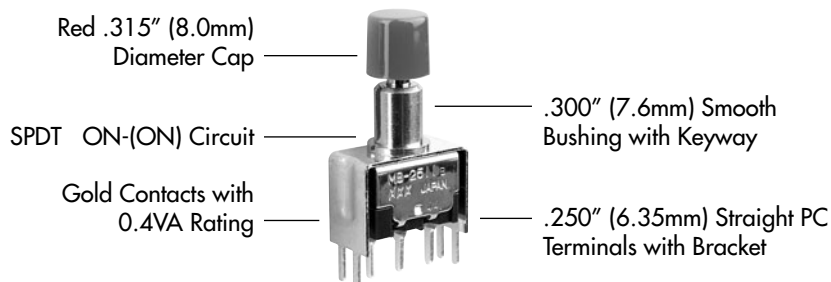

Toggle

Rockers

Pushbuttons

Illuminated PB

Programmable

Keylocks

Rotaries

Slides

Tactiles

Tilt

Touch

Indicators

Accessories

POLES & CIRCUITS

Pole	Model	Plunger Position () = Momentary		Connected Terminals		Throw & Switch Schematics
		Normal	Down	Normal	Down	
						Note: Terminal numbers are not actually on the switch.
SP	MB2511	ON	(ON)	3-1	3-2	SPDT
DP	MB2521	ON	(ON)	3-1 6-4	3-2 6-5	DPDT

BUSHING

S2 .300" (7.6mm)
Smooth with Keyway

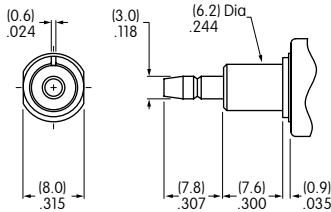

Panel Cutout

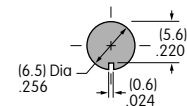

CONTACT MATERIALS & RATINGS

W Silver over Silver

Power Level

3A @ 125V AC

G Gold over Brass or Copper

Logic Level

0.4VA maximum @ 28V AC/DC maximum

Note: Complete explanation of operating range in Supplement section.

TERMINALS

13 .250" (6.35mm) Terminal
with .465" (11.8mm) Bracket

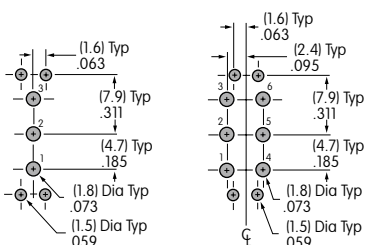
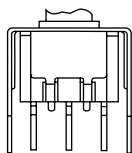

30 Right Angle PC
Single Pole only

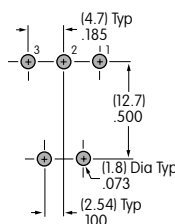
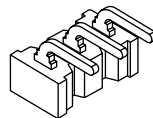

45 Vertical PC

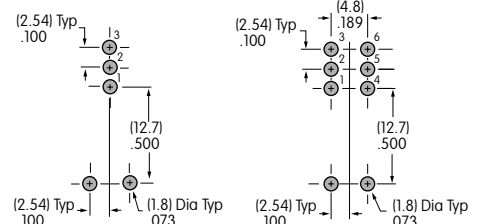
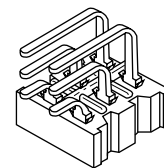

CAPS & CAP COLORS

B AT443
.315" (8.0mm) Diameter Cap



Material: Polycarbonate

Finish: Glossy

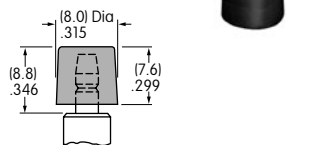

C AT442
.394" (10.0mm) Diameter Cap



Material: Polycarbonate

Finish: Glossy

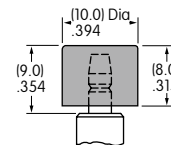

Cap Colors Available:



Black



White



Red



Yellow



Green



Blue

TYPICAL SWITCH DIMENSIONS

Single Pole

Double Pole

Straight PC • Bracket

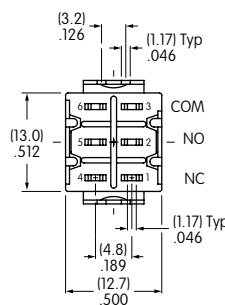
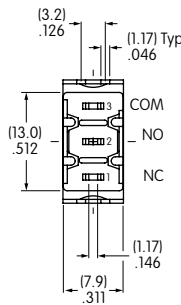
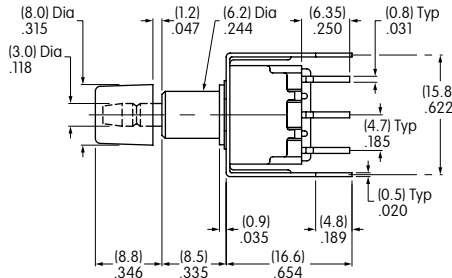
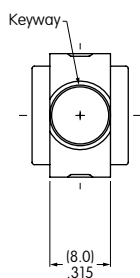

MB2511S2G13-BC

Single Pole

Right Angle PC

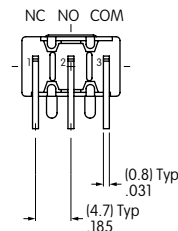
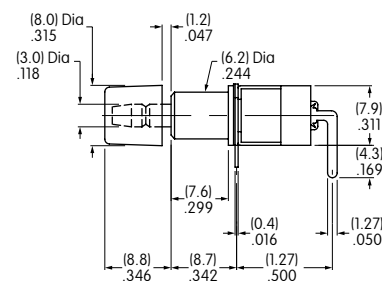
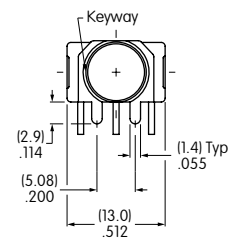

MB2511S2G30-BC

Single Pole

Double Pole

Vertical PC

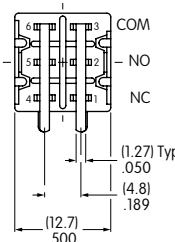
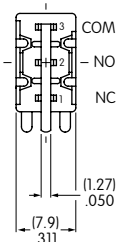
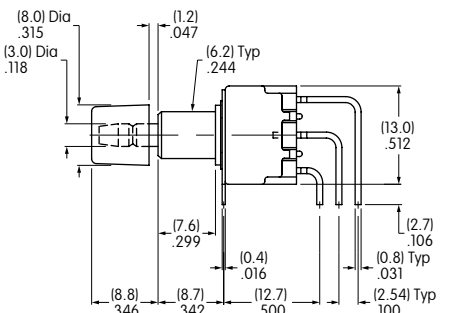
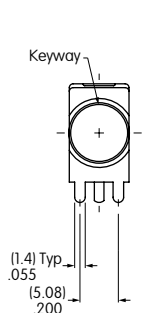

MB2511S2G45-BC

Toggles
Rockers
Pushbuttons
Illuminated PB
Programmable
Keylocks
Rotaries
Slides
Tactiles
Tilt
Touch
Indicators
Accessories
Supplement

TYPICAL SWITCH ORDERING EXAMPLE

MB25

11

J

W

01

A

Poles & Circuits

11	SPDT	ON	(ON)
21	DPDT	ON	(ON)

() = Momentary

Contact Materials & Ratings

W	Silver Rated 3A @ 125V AC
G	Gold Rated 0.4VA max @ 28V AC/DC max

Cap & Cap Colors

A	Black
B	White
C	Red
E	Yellow
F	Green
G	Blue
H	Gray

Mounting Frame

J	Snap-in Frame
----------	---------------

Terminals

01	Solder Lug
-----------	------------

IMPORTANT:





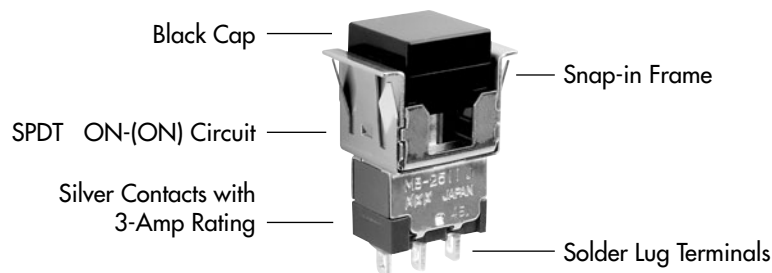

Switches are supplied without UL, cULus & CSA marking unless specified. **UL, cULus & CSA recognized only when ordered with marking on the switch.** Specific models, ratings, & ordering instructions are noted on General Specifications page.

DESCRIPTION FOR TYPICAL ORDERING EXAMPLE

MB2511JW01-A

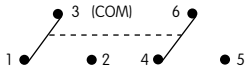

POLES & CIRCUITS

Pole	Model	Plunger Position () = Momentary		Connected Terminals		Throw & Switch Schematics
		Normal	Down	Normal	Down	
SP	MB2511	ON 	(ON) 	3-1 	3-2 	Note: Terminal numbers are not actually on the switch. SPDT 
DP	MB2521	ON	(ON)	3-1 6-4	3-2 6-5	DPDT 

MOUNTING FRAME

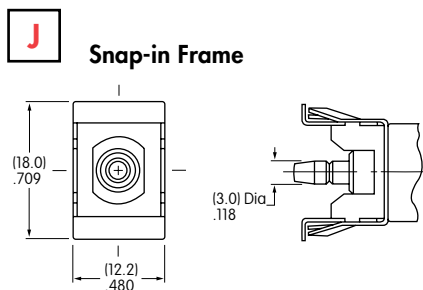

Panel Cutout for Single Pole without Bezel

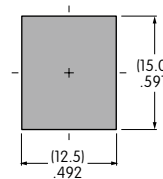

Panel Cutout for Double Pole without Bezel

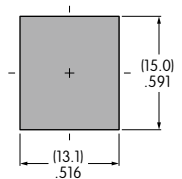

Panel Thickness without Bezel: .039" ~ .157" (1.0mm ~ 4.0mm)
Panel Thickness with Bezel: .039" ~ .126" (1.0mm ~ 3.2mm)

CONTACT MATERIALS & RATINGS

W Silver over Silver

Power Level

3A @ 125V AC

G Gold over Brass or Copper

Logic Level

0.4VA maximum @ 28V AC/DC maximum

Note: Complete explanation of operating range in Supplement section.

TERMINALS

01 Solder Lug

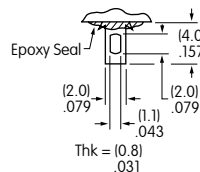

CAP & CAP COLORS

AT465
.453" (11.5mm) Square Cap

Material: Polycarbonate
Finish: Glossy

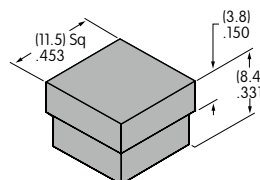

Contact factory for matte finish.

Cap Colors Available:

- A** Black
- B** White
- C** Red
- E** Yellow
- F** Green
- G** Blue
- H** Gray

Toggles
Rockers
Pushbuttons
Illuminated PB
Programmable
Keylocks
Rotaries
Slides
Tactiles
Tilt
Touch
Indicators
Accessories
Supplement

TYPICAL SWITCH DIMENSIONS

Solder Lug



MB2511JW01-A

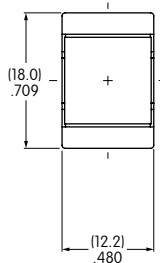

Single Pole

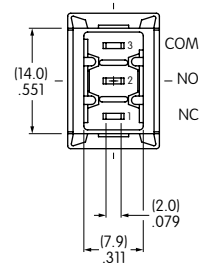
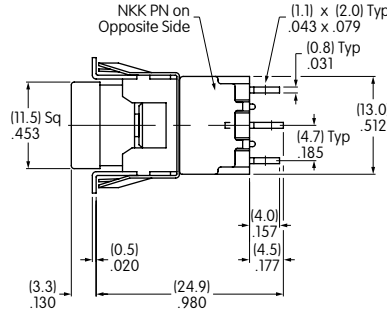

Solder Lug



MB2521JW01-C

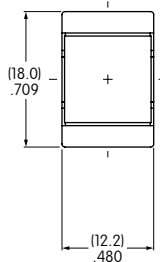

Double Pole

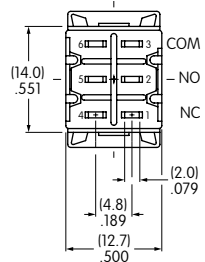
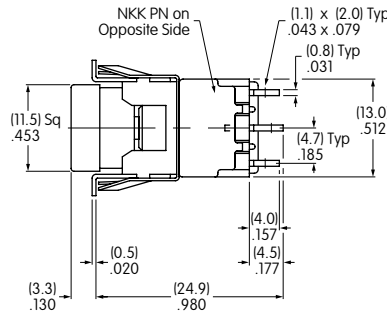

OPTIONAL SNAP-IN BEZELS & BEZEL COLORS

AT207 Bezel

Material: Polycarbonate
Finish: Glossy

Colors:
Black, White, Red, Yellow,
Green, Blue, Gray

Contact factory for matte finish.

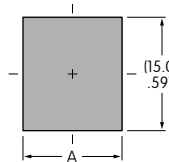
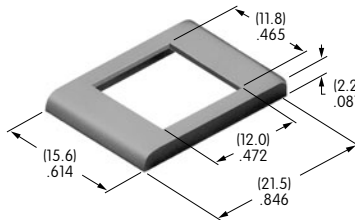

	Single Pole	Double Pole
A	(12.5mm) .492"	(13.1mm) .516"

AT208 Bezel for AT070 LED

Material: Polycarbonate
Finish: Glossy

Color: Black

Contact factory for matte finish.

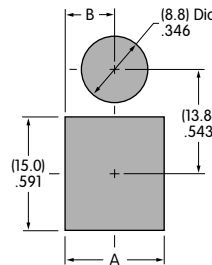
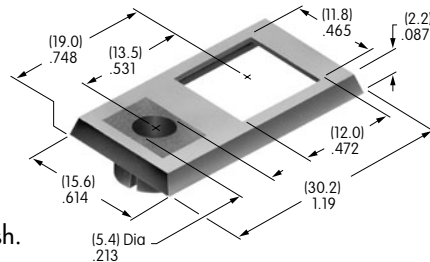

	Single Pole	Double Pole
A	(12.5mm) .492"	(13.1mm) .516"
B	(6.25mm) .246"	(6.55mm) .258"

AT212 Bezel for AT617 LED

Material: Polycarbonate
Finish: Semi-glossy

Color: Black

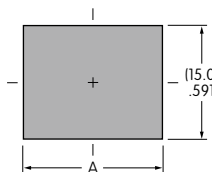
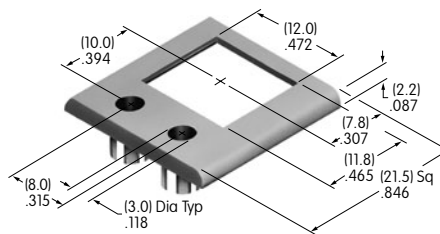

	Single Pole	Double Pole
A	(18.4mm) .724"	(18.7mm) .736"

OPTIONAL SNAP-IN BEZELS & BEZEL COLORS

AT213 Bezel for AT618 LED

Material:
Polycarbonate
Finish:
Semi-glossy

Color:
Black

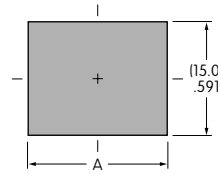
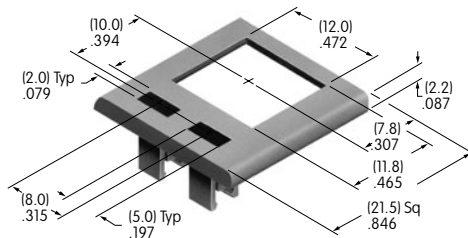

	Single Pole	Double Pole
A	(18.4mm) .724"	(18.7mm) .736"

Bezel Assembly

1. Pry out tab on bezel to a 45° angle.

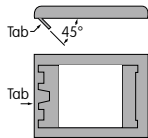

2. Insert switch frame under tab and snap on the bezel.

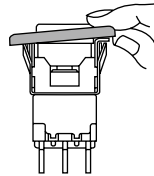

3. Push tab back into place.

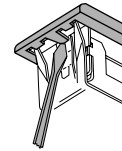

4. Snap assembled bezel and switch into panel.

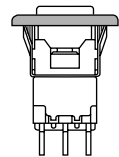

LED COLORS & SPECIFICATIONS

Bezel Orientation on Switch

AT070 LED For Bezel AT208 with 1 LED

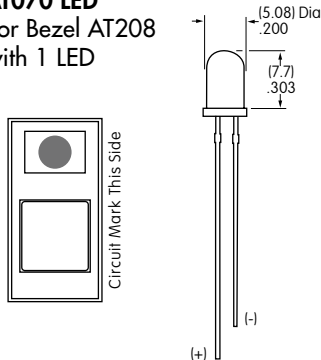

AT617 LED For Bezel AT212 with 2 Round LEDs

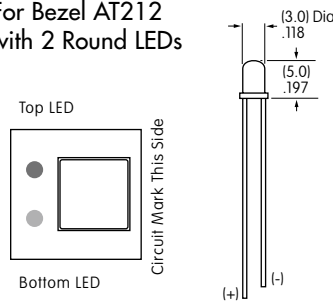

AT618 LED For Bezel AT213 with 2 Rectangular LEDs

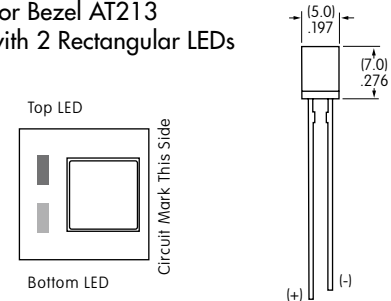

Note: Lead lengths may differ from manufacturing lot to lot. The longer lead is the anode (+).

	Color	AT070		AT617			AT618		
		C	F	C	E	F	C	E	F
Forward Peak Current	I_{FM}	25mA	50mA	30mA	30mA	25mA	10mA	30mA	30mA
Typical Forward Current	I_F	20mA	30mA	20mA	20mA	20mA	8mA	24mA	24mA
Forward Voltage	V_F	2.8V	2.1V	2.0V	2.1V	2.2V	1.9V	2.0V	2.1V
Reverse Peak Voltage	V_{RM}	4V	5V	5V	5V	5V	5V	5V	5V
Current Reduction Rate Above 25°C	ΔI_F	0.33 mA/°C	0.40 mA/°C	0.40 mA/°C	0.40 mA/°C	0.33 mA/°C	0.13 mA/°C	0.40 mA/°C	0.40 mA/°C
Ambient Temperature Range (when used with a bezel)		-10° ~ +70°C		-15° ~ +70°C			-15° ~ +70°C		

The electrical specifications shown are determined at a basic temperature of 25°C.
LED circuit is independent of switch operation. LED is colored in OFF state.

If the source voltage is greater than the rated voltage of the LED, a ballast resistor must be connected in series with the LED.
The ballast resistor calculation and more lamp detail are shown in the Supplement section.

GENERAL SPECIFICATIONS FOR SB25, SB60s, SB221s, SB265

Electrical Capacity (Resistive Load)

Power Level: Shown in the following tables

Other Ratings

Contact Resistance:	10 milliohms maximum
Insulation Resistance:	200 megohms minimum @ 500V DC for SB221s, SB25, & SB265; 1,000 megohms minimum @ 500V DC for SB60s.
Dielectric Strength:	1,500V AC minimum for SB265 & SB25 for 1 minute minimum; 2,000V AC minimum between contacts for SB221s & SB60s for 1 minute minimum; 1,500V AC minimum between contacts & case for SB221s & SB60s for 1 minute minimum
Mechanical Life:	50,000 operations minimum for SB221s; 30,000 operations minimum for SB25, SB60s, SB265
Electrical Life:	10,000 operations minimum
Total Travel:	SB221s .116" (2.95mm); SB60s .094" (2.4mm); SB265 .213" (5.4mm); SB25 .195" (4.95mm)
Operating Temp Range:	-10°C through +70°C (+14°F through +158°F)

Materials & Finishes

Cap:	Polybutylene terephthalate (PBT) (AT414)
Plunger:	Polyacetal or brass with nickel plating
Bushing:	Brass with nickel plating
Case:	Phenolic resin or melamine phenolic resin
Case Cover:	Steel with zinc plating
Movable & Stationary Contacts:	Copper with silver plating for SB221s; silver alloy with silver plating for SB25, SB60s, & SB265
Terminals:	Copper with tin plating for SB25 & SB60s; copper with silver plating for SB265



Installation



Soldering Time & Temp: Manual Soldering (Solder Lug): See Profile A in Supplement section.

Standards & Certifications

- UL: File No. E44145 - Recognized only when ordered with marking on switch.**
Add "/U" or "/CUL" to end of part number to order UL recognized switch.
UL or cULus recognition designated beside part numbers on following pages.
See Supplement section to find UL or cULus rating details.
- CSA: File No. 023535_0_000 - Certified only when ordered with marking on switch.**
Add "/C" to end of part number to order CSA certified switch.
CSA certification designated beside part numbers on following pages.
See Supplement section to find CSA rating details.

SINGLE POLE WITH SOLDER LUG * OR SCREW LUG

* UL, cULus & CSA recognized only when ordered with marking on switch (see General Specs)			Pushbutton Position/Connected Terminals () = Momentary		Electrical Capacity (Resistive)	
Model	* Approvals UL cULus SP	Pole & Throw	Normal 	Down 	AC 125V	AC 250V
SB221NO	— — ✓	SPST	OFF —	(ON) 1-4	3A	1.5A
SB221NC	✓ — ✓	SPST	ON 1-4	(OFF) —	3A	1.5A
SB221TNO	— — ✓	SPST	OFF —	(ON) 1-4	3A	1.5A
SB221TNC	✓ — ✓	SPST	ON 1-4	(OFF) —	3A	1.5A

Suffix T = Screw Lug **Throw & Schematic:** SPST SB221NO  SPST SB221NC  Note: Terminal numbers are actually on the switch.

Notes: Standard Hardware: AT504M Knurled Nut, AT508 Lockwasher, AT527M Hex Backup Nut. See Accessories & Hardware section.
* Wire harness & cable assemblies offered only in Americas.

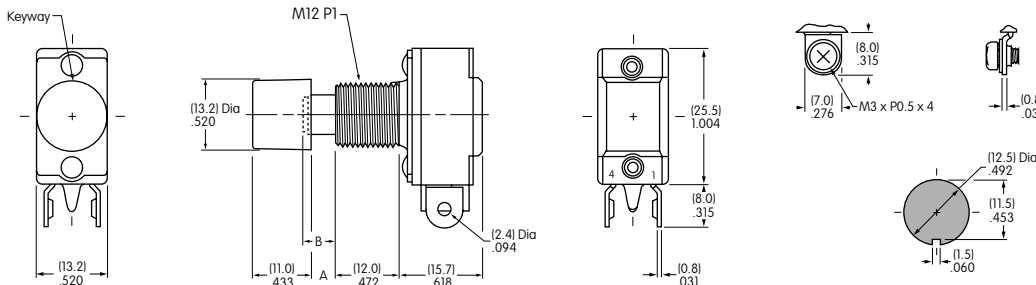



Dimension A: .185" (4.7mm) for NO model & .150" (3.8mm) for NC model.
Dimension B Plunger Extension: .197" (5.0mm) for NO model & .161" (4.1mm) for NC model.

Panel Thickness .193" (4.9mm)



SB221NO
Supplied with AT414 Black Cap

DOUBLE POLE WITH SOLDER LUG *

* UL & cULus recognized only when ordered with marking on switch (see General Specs)			Pushbutton Position/Connected Terminals () = Momentary		Electrical Capacity (Resistive)	
Model	* Approvals UL cULus SP	Pole & Throw	Normal 	Down 	AC 125V	AC 250V
SB61A	✓ — —	DPDT	ON 2-3 5-6	(ON) 2-1 5-4	10A	5A
SB61B	— — —	DPDT	ON 2-3 5-6	(ON) 2-1 5-4	3A	1.5A
SB63A	— — —	DPDT	ON 2-3 5-6	(ON) or Lockdown ON 2-1 5-4	10A	5A

Lockdown for SB63A is achieved by actuating and then turning the button clockwise.

Throw & Schematic:

DPDT

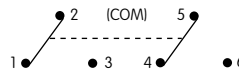

Note: Terminal numbers are actually on the switch.

Notes: Standard Hardware: AT504M Knurled Nut, AT508 Lockwasher, AT527M Hex Backup Nut. See Accessories & Hardware section.
* Wire harness & cable assemblies offered only in Americas.

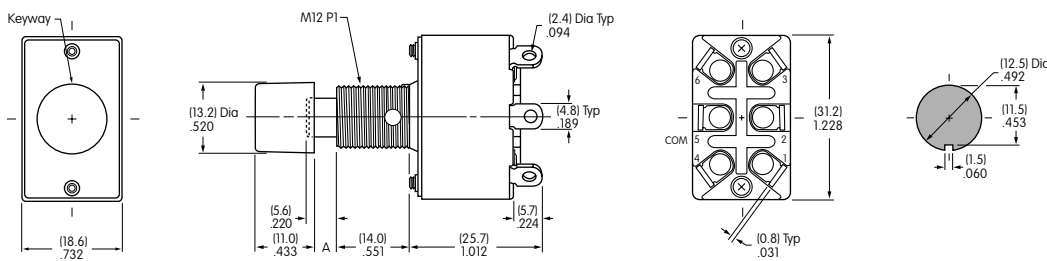

Dimension A: .169" (4.3mm) for SB61 model and .130" (3.3mm) for SB63 model.

Panel Thickness .193" (4.9mm)



SB61A
Supplied with AT414 Black Cap

Toggles

Rockers

Pushbuttons

Illuminated PB

Programmable

Keylocks

Rotaries

Slides

Tactiles

Tilt

Touch

Indicators

Accessories

Supplement

DOUBLE POLE WITH SOLDER LUG *

* UL, cULus & CSA recognized only when ordered with marking on switch (see General Specs)			Pushbutton Position/Connected Terminals () = Momentary		Electrical Capacity (Resistive)	
Model	* Approvals	Pole & Throw	Normal	Down	AC 125V	AC 250V
SB25		DPDT	ON	ON	15A	9A

Throw & Schematic:

DPDT

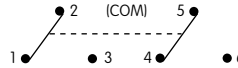

Note: Terminal numbers are actually on the switch.

Notes: Standard Hardware: AT504M Knurled Nut, AT508 Lockwasher, AT527M Hex Backup Nut. See Accessories & Hardware section.

* Wire harness & cable assemblies offered only in Americas.

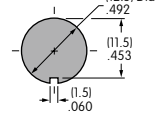
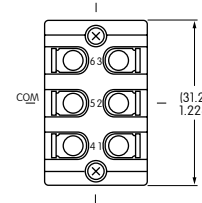
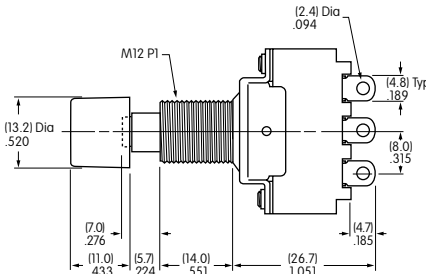
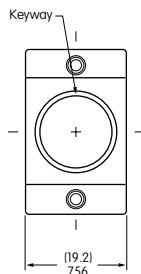

SB25

Supplied with AT414 Black Cap

Panel Thickness .193" (4.9mm)

SINGLE POLE WITH SOLDER LUG *

* UL, cULus & CSA recognized only when ordered with marking on switch (see General Specs)			Pushbutton Position/Connected Terminals () = Momentary		Electrical Capacity (Resistive)	
Model	* Approvals	Pole & Throw	Normal	Down	AC 125V	AC 250V
SB265		SPST	ON	OFF	6A	3A

Throw & Schematic:

SPST



Note: Terminal numbers are actually on the switch.

Notes: Standard Hardware: AT504M Knurled Nut, AT508 Lockwasher, AT527M Hex Backup Nut. See Accessories & Hardware section.

* Wire harness & cable assemblies offered only in Americas.

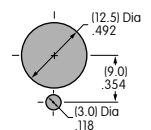
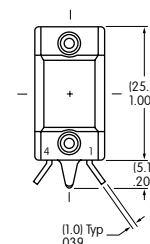
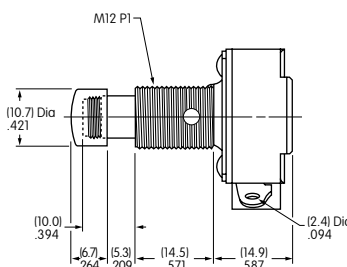
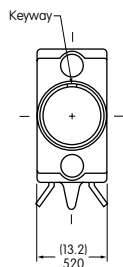

SB265

Supplied with Chrome Plated Brass Cap

Panel Thickness .291" (7.4mm)

GENERAL SPECIFICATIONS

Electrical Capacity

Resistive Load: 15A & ½ HP @ 125 or 250V AC for high capacity models
Lamp Load: 5A @ 125V AC

Other Ratings

Contact Resistance: 15 milliohms maximum
Insulation Resistance: 100 megohms minimum @ 500V DC
Dielectric Strength: 1,000V AC minimum between contacts for 1 minute minimum;
 1,500V AC minimum between contacts & case for 1 minute minimum
Mechanical Life: 1,000,000 operations minimum
Electrical Life: 50,000 operations minimum
Travel: Pretravel .047" (1.19mm); Overtravel .040" (1.01mm); Differential .011" (0.27mm)
Operating Temp Range: -40°C through +85°C (-40°F through +185°F)

Materials & Finishes

Caps & Shrouds: Polycarbonate with glossy finish or PBT
Plunger: Polyacetal or brass with nickel plating
Bushing: Steel with zinc plating or glass fiber reinforced polyamide
Case: Polyester
Movable & Stationary Contacts: Silver alloy
Terminals: Brass with silver plating

Standards & Certifications

UL: Internal snap switch is UL recognized.
CSA: Internal snap switch is CSA certified.

TYPICAL SWITCH ORDERING EXAMPLE

SCB

2

5

P

15

A

—

4

CA

Poles

1	SPDT
2	DPDT

Circuits

5	ON	(ON)
6	ON	ON

() = Momentary

Bushings

P	Plastic (with momentary only)
S	Steel

Rating

15	15A
----	-----

Terminals

A	.187" (4.75mm) Quick Connect
* B	.250" (6.35mm) Quick Connect

Note: Contact factory for availability of screw lug and solder lug models.

* Available in Americas only

Caps & Shrouds

For Momentary

3	.520" (13.2mm) Diameter Cap
---	-----------------------------

For Momentary & Alternate Action

4	Round Cap & Shroud (AT454 & AT455)
5	Rectangular Cap & Shroud (AT452 & AT453)

DESCRIPTION FOR TYPICAL ORDERING EXAMPLE

SCB25P15A-4CA

Round Red Cap with Black Shroud

Plastic Bushing

DPDT ON-(ON) Circuit

15A Rating

.187" (4.75mm) Quick Connect Terminals

Colors

Caps		Shrouds
A	Black	A
B	White	B
C	Red	—
F	Green	—
G	Blue	—
H	Gray	H

Note: Standard hardware is provided with caps. See Bushing detail for more information.

Toggles
 Rockers
 Pushbuttons
 Illuminated PB
 Programmable
 Keylocks
 Rotaries
 Slides
 Tactiles
 Tilt
 Touch
 Indicators
 Accessories
 Supplement

Toggles

Rockers

Pushbuttons

Illuminated PB

Keylocks

Rotaries

Slides

Tactiles

Tilt





Touch

Indicators

Accessories

Supplement

POLES & CIRCUITS

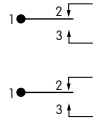
		Plunger Position () = Momentary		Connected Terminals		Throw & Schematics
Pole	Model	Normal  Keyway	Down 	Normal  Keyway	Down 	Note: Terminal numbers are actually on the switch.
SP	SCB15 SCB16	ON ON	(ON) ON	1-2	1-3	
DP	SCB25 SCB26	ON ON	(ON) ON	1-2 1-2	1-3 1-3	SP with 2 switches 

BUSHINGS

P Plastic
(for Momentary only)

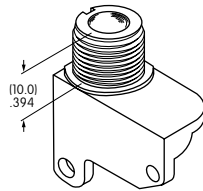

S Steel

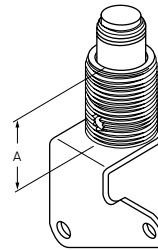

"A" =
11.2mm
Momentary
15.5mm
Alternate Action

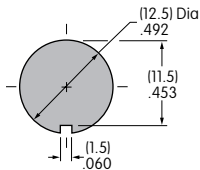

Maximum Effective Panel Thickness:
.165" (4.2mm) without Shroud
.157" (4.0mm) with Shroud

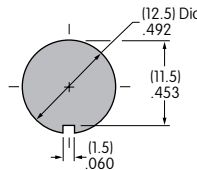

Maximum Effective Panel Thickness:
Momentary: .177" (4.5mm) without Shroud
.157" (4.0mm) with Shroud
Alternate Action: .354" (9.0mm)

Standard Hardware Provided with Caps

Cap Option 3: AT504M Knurled Face Nut, AT508 Lockwasher, AT527M Hex Mounting Nut

Cap Options 4 & 5: AT508 Lockwasher & AT527M Hex Mounting Nut

TERMINALS

A .187" (4.75mm)
Quick Connect

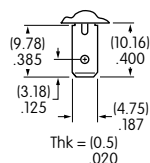

B .250" (6.35mm)
Quick Connect

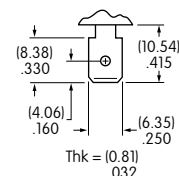

TYPICAL SWITCH DIMENSIONS

.520" (13.2mm) Dia. Cap • .187" (4.75mm) Quick Connect

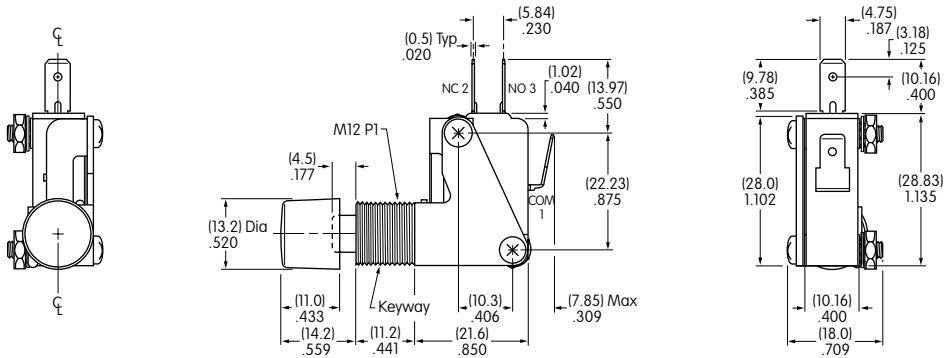

SCB15S15A-3C

Round Cap & Shroud • .187" (4.75mm) Quick Connect

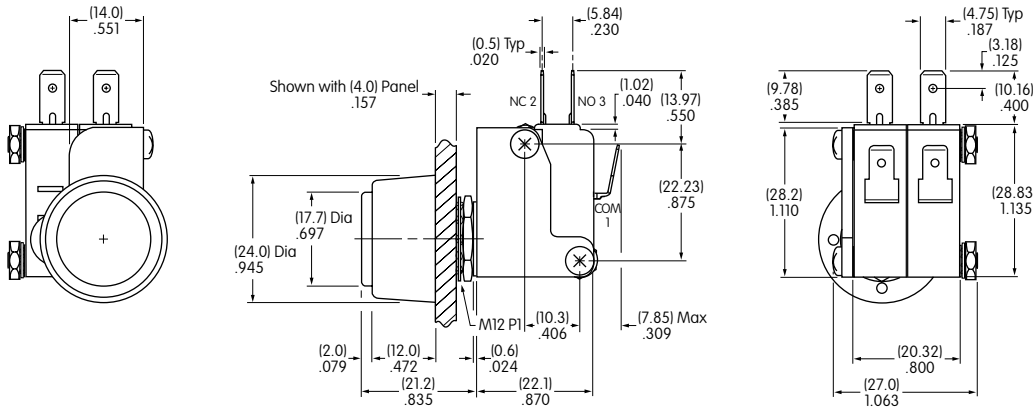

SCB25P15A-4CA

Rectangular Cap & Shroud • .250" (6.35mm) Quick Connect

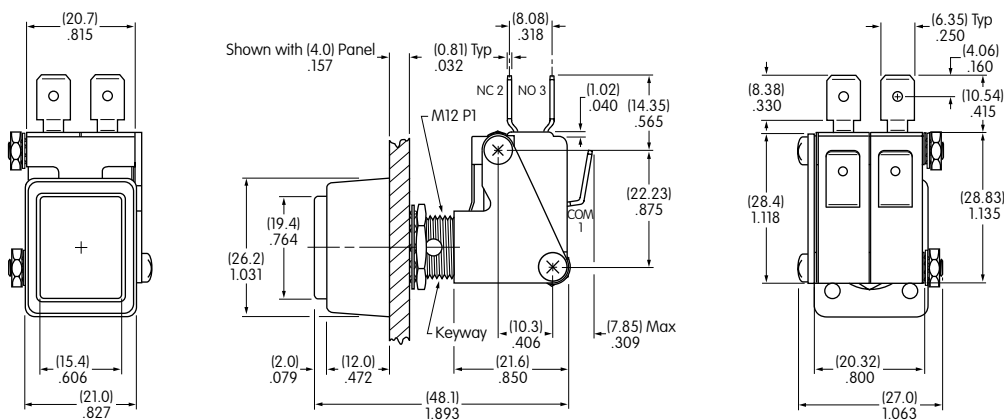

SCB26S15B-5CA

General Specifications

Electrical Capacity (Resistive Load)

Power Level: 6A @ 125V AC & 3A @ 250V AC or 6A @ 30V DC

Other Ratings

Contact Resistance: 10 milliohms maximum for solder lug & screw terminal models
30 milliohms maximum for wire lead terminal models

Insulation Resistance: 200 megohms minimum @ 500V DC

Dielectric Strength: 1,500V AC minimum for 1 minute minimum

Mechanical Life: 30,000 operations minimum

Electrical Life: 15,000 operations minimum

Contact Timing: Break before make

Total Travel: Alternate Action .177" (4.5mm); Momentary Action .110" (2.8mm)

Materials & Finishes

Plunger: Brass with nickel plating

Bushing & Outer Case: Fiberglass reinforced polyamide (UL94V-0 outer case)

Inner Case: Melamine

Inner Sealing Ring: Silicone rubber

Outer Sealing Ring: Natural rubber

Movable Contactor: Copper with silver plating

Movable Contacts: Silver alloy with silver plating

Stationary Contacts: Silver alloy with silver plating

Terminals: Brass with silver plating for screw lug models;
brass with tin plating for solder lug & wire lead models

Wire Lead Covers: Heat resistant polyvinyl chloride (Leads are AWG 16.)

Environmental Data

Operating Temp Range: -30°C through +70°C (-22°F through +158°F)

Humidity: 90 ~ 95% humidity for 96 hours @ 40°C (104°F)

Vibration: 10 ~ 55Hz with peak-to-peak amplitude of 1.5mm traversing the frequency range & returning in 1 minute; 3 right angled directions for 2 hours

Shock: 50G (490m/s²) acceleration (tested in 6 right angled directions, with 5 shocks in each direction)

Installation

Mounting Torque: 1.5Nm (13 lb•in)

Soldering Time & Temp: Manual Soldering: See Profile A in Supplement section.

Standards & Certifications

Flammability Standards: UL94V-0 outer case

Wiring Material Standards: UL AWM 1015 Recognized at Flammability VW-1;
Temperature Range -20°C ~ +105°C; Maximum Load 600V; AWG 16
CSA TEW 105 Certified at Temperature Range -20°C ~ +105°C;
Maximum Load 600V

Distinctive Characteristics

Single unit construction of the bushing and case gives added protection from environmental elements.

Specially designed contact mechanism for breaking light welds.

Minimal contact bounce is achieved with specially designed interlocked switching mechanism.

Outer housing of heat resistant resin meets UL 94V-0 flammability standard and provides high arc and tracking resistance.

Solder lug and screw terminal models meet IP67 of IEC60529 Standards at front panel (dust tight and water protected for temporary immersion). Behind panel standard is IP60 (dust tight but not water protected).

Wire lead models conform fully to IP67 of IEC60529 Standards at front and behind panel (dust tight and water protected for temporary immersion). These models are epoxy sealed at the switch base and covered by an outer case for further protection from dust and water (not operable under water).

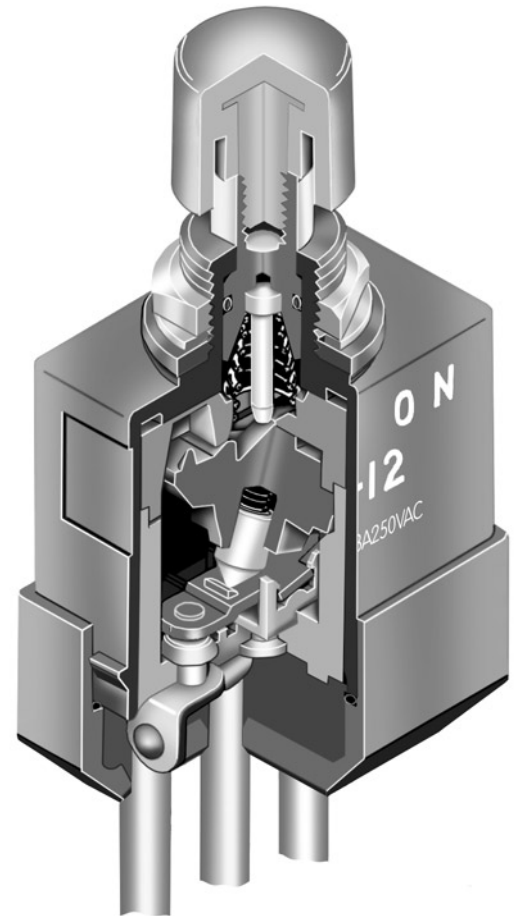

Actual Size

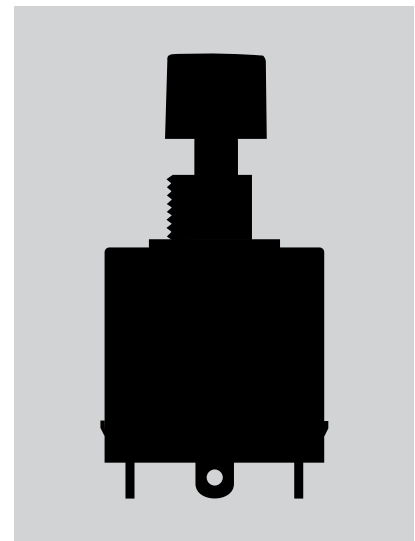

- Supplement
- Accessories
- Indicators
- Touch
- Tilt
- Tactiles
- Slides
- Rotaries
- Keylocks
- Programmable
- Illuminated PB
- Pushbuttons
- Rockers
- Toggles

TYPICAL SWITCH ORDERING EXAMPLE

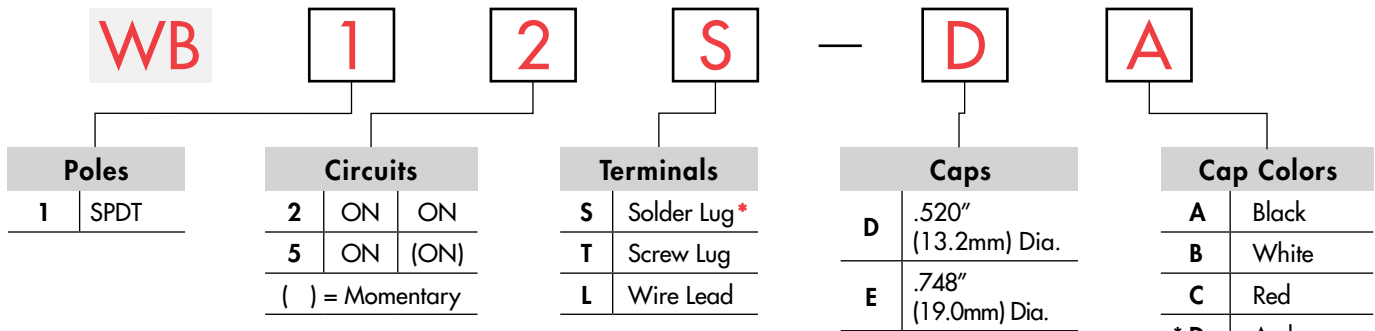

DESCRIPTION FOR TYPICAL ORDERING EXAMPLE

WB12S-DA

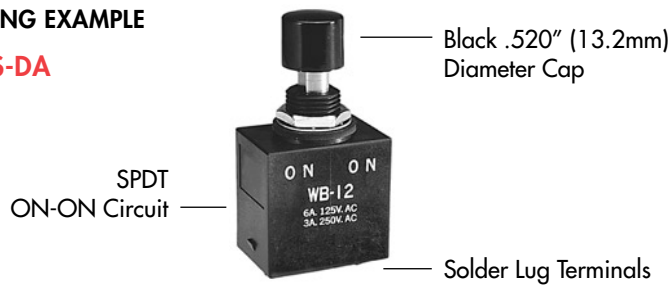

* Not available with cap code E

* Wire harness & cable assemblies offered only in Americas

POLES & CIRCUITS

		Actuator Position () = Momentary		Connected Terminals		Throw & Schematics
Pole	Model	Normal	Down	Normal	Down	
SP	WB12	ON	ON	1-1b	1-1a	Note: Terminal numbers are not actually on wire lead models. SPDT
SP	WB15	ON	ON (ON)	1-1b	1-1a	

STANDARD WIRE COLOR SCHEME

Wire leads are covered with heat resistant vinyl in accordance to UL 1015 and CSA TEW 105 Standards for Appliance Wiring Material (AWM).

Terminal Numbers & Wire Colors			
Models	1a	1	1b
WB12L, WB15L	White	Black	Red

TYPICAL SWITCH DIMENSIONS

Solder Lug

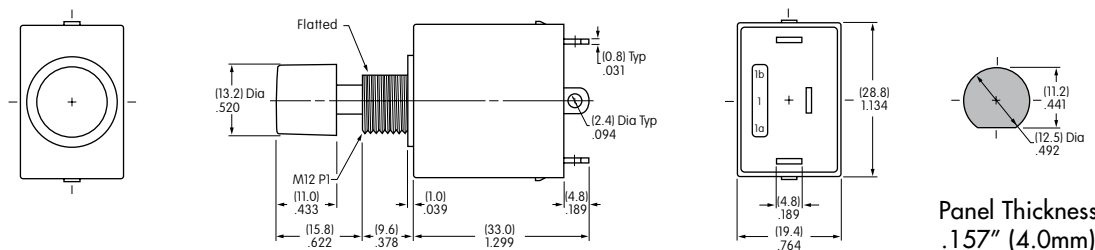

WB15S-DA

TYPICAL SWITCH DIMENSIONS

Screw Lug



WB12T-DA

Wire Lead



WB12L-DA

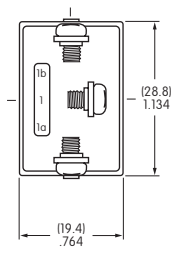
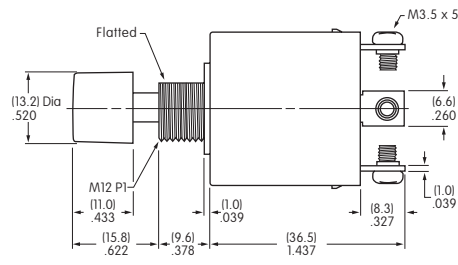
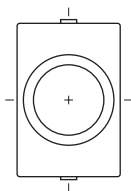

Panel Thickness
.157" (4.0mm)

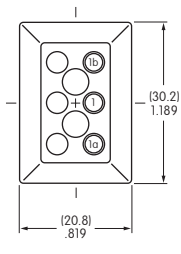
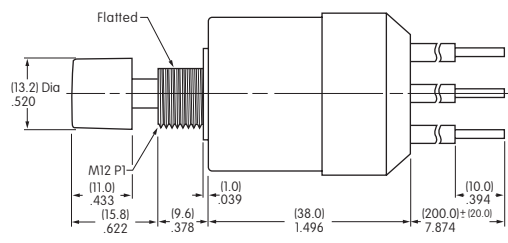
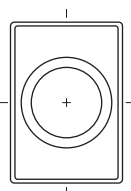

Panel Thickness
.157" (4.0mm)

CAPS & CAP COLORS

D AT414
.520" (13.2mm) Diameter

Colors Available:
A B C D E F G H
Material: PBT Finish: Glossy

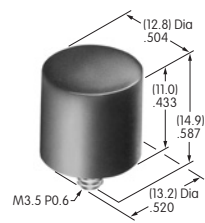

E AT412
.748" (19.0mm) Diameter

Colors Available:
A B C F
Material: Polystyrene Finish: Glossy

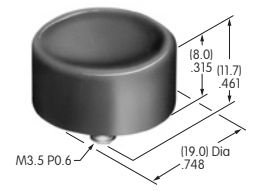

- Cap Color Codes: **A** Black **B** White **C** Red **D** Amber **E** Yellow **F** Green **G** Blue **H** Gray

STANDARD HARDWARE

AT503M
Hex Face Nut

Material:
Brass with
chrome plating

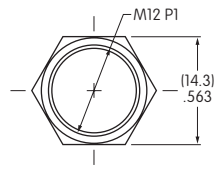

1 supplied
with each
switch

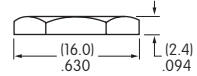

AT508
Internal Tooth Lockwasher

Material:
Steel with
zinc/chromate

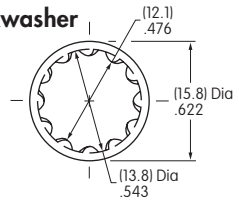

1 supplied
with each
switch



AT401P
O-ring

Material:
Nitrile
butadiene
rubber

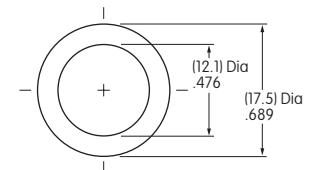

1 supplied
with each
switch

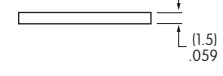

Toggles
Rockers
Pushbuttons
Illuminated PB
Programmable
Keylocks
Rotaries
Slides
Tactiles
Tilt
Touch
Indicators
Accessories
Supplement